

# IEM615 Series Managed Industrial Ethernet Switch Module Hardware User Manual

Version: 03

Issue Date: 2020-07-24

**Copyright © 2020 3onedata Co., Ltd. All rights reserved.**

No company or individual is allowed to duplicate or transmit this manual in any forms without written permission issued by 3onedata Co., Ltd.

## **Trademark statement**

 **3onedata**<sup>®</sup> and  **3One data**<sup>®</sup> are the registered trademark owned by 3onedata Co., Ltd. And other trademarks mentioned in this manual belong to their corresponding companies.

## **Notes**

Purchased product, service or features should be constrained by 3onedata commercial contracts and clauses. The whole or part product, service or features described in this document may beyond purchasing or using range. 3onedata won't make any statement or warranty for this document content unless any other appointment exists.

Due to product version upgrading or other reason, this document content will be upgraded periodically. Unless other appointment exists, this document only for usage guide, all statement, information and suggestion in this document won't constitute any warranty.

# 3onedata

Make network communication more reliable



Please scan our QR code for more details

## 3onedata

Make network communication more reliable



BlueEyes pro



Embedded Industrial Ethernet Switch Modules

Embedded Serial Device Server Modules



Industry-specialized Products  
(Rail Transit, Power, Smart City, Pipe Gallery...)

Honor · Quality · Service



Layer 2 (Unmanaged) Managed Industrial Ethernet Switch  
Layer 3 Managed Industrial Ethernet Switch  
Industrial PoE Switch



BlueEyes Pro Management Software  
VSP Virtual Serial Port Management Software  
SNMP Management Software



Modbus Gateway  
Serial Device Server  
Media Converter  
CAN Device Server  
Interface Converter



Industrial Wireless Products

## 3onedata Co., Ltd.

Headquarter address: 3/B, Zone 1, Baiwangxin High Technology Industrial Park, Song Bai Road, Nanshan District, Shenzhen, 518108, China

Technology support: [tech-support@3onedata.com](mailto:tech-support@3onedata.com)

Service hotline: +86-400-880-4496

E-mail: [sales@3onedata.com](mailto:sales@3onedata.com)

Fax: +86-0755-26703485

Website: <http://www.3onedata.com>

# Preface

The managed industrial Ethernet switch module hardware manual has introduced following features of this module:

- Product overview
- Encapsulation and size
- Pins definition
- Reference circuit

## Readers

This manual mainly suits for engineers as follows:





- On-site technical support and maintenance staffs
- Hardware engineers

## Text Format Convention

Format	Description
“”	Words with "" represent the interface words. e.g.: "The port No."
>	Multi-level path is separated by ">". Such as opening the local connection path description: Open "Control Panel> Network Connection> Local Area Connection".
Light Blue Font	Represent the words click to achieve hyperlink. Font color as: "Light blue".
About This Chapter	The "About This Chapter" section provides links to each section and corresponding principles / operating chapters in this chapter.

## Icon Convention

Format	Description
 Notice	Reminder the announcements in the operation, improper operation may result in data loss or equipment damage.

Format	Description
 Warning	Pay attention to the notes on the mark, improper operation may cause personal injury.
 Note	Make a necessary supplementary instruction for operation description.
 Key	Configuration, operation, or tips for device usage.
 Tips	Pay attention to the operation or information to ensure success device configuration or normal working.

## Revision Record

Version NO.	Revision Data	Revision Description
01	2013-11-21	Product release
02	2018-12-28	Document upgrading
03	2020-07-24	Update the structure diagram size of module aperture
04	2020-09-04	Update the specification of pin header

# Content

<b>PREFACE</b> .....	<b>1</b>
<b>CONTENT</b> .....	<b>1</b>
<b>1 PRODUCT OVERVIEW</b> .....	<b>1</b>
1.1 PRODUCT INTRODUCTION .....	1
1.2 PRODUCT SPECIFICATION .....	2
<b>2 DIMENSION</b> .....	<b>3</b>
2.1 PACKAGE DESIGN .....	3
2.2 PRODUCT DIMENSION .....	5
<b>3 DESCRIPTION OF PIN DEFINITION</b> .....	<b>6</b>
3.1 VIEW OF PIN DEFINITION .....	6
3.2 DESCRIPTION OF PIN DEFINITION NAME .....	7
3.3 LIST OF PIN DEFINITION .....	8
3.4 DETAILED DESCRIPTION OF THE PIN DEFINITION .....	11
3.4.1 100M Ethernet Port .....	11
3.4.2 Power Supply and Ground Signal .....	13
3.4.3 TTL UART Interface .....	13
3.4.4 TTL CAN Port .....	14
3.4.5 CONSOLE Port (Debugging Port) .....	14
3.4.6 I/O Alarm Interface .....	15
3.4.7 Indicator .....	15
3.4.8 Other Pins .....	16
3.4.9 Reserved Pins .....	17
<b>4 REFERENCE CIRCUIT</b> .....	<b>18</b>
4.1 100M ETHERNET PORT .....	18
4.2 TTL UART PORT .....	20
4.3 TTL CAN PORT .....	23
4.4 CONSOLE PORT (DEBUGGING PORT) .....	24
4.5 I/O ALARM INTERFACE .....	25
4.6 RESET INTERFACE .....	25

# 1 Product Overview

## 1.1 Product Introduction

IEM615 series are layer 2 managed embedded industrial Ethernet switch modules with the features of high integration, small size, rich functions, simple and convenient operation. This series include following port types:

- 5 100M Ethernet ports, support 10/100Base-T(X) copper port and 100Base-FX fiber port.
- 2 TTL UART ports, expandable RS-232/485/422 serial port, support serial port server function of serial port to Ethernet.
- 2 TTL CAN ports, support the CAN server function of CAN to Ethernet bidirectional transparent transmission.
- 1 CONSOLE port for command line coordination and module debugging.
- 2 I/O alarm ports for expandable relay alarm.

Optional models	100M Ethernet port	TTL UART port	TTL CAN port	Power supply
IEM615-2D	5	2	—	3.3VDC
IEM615-1D-1C	5	1	1	
IEM615-2C	5	—	2	



Note

- This series of modules only support the combination of 2 CAN or UART ports at the same time, but cannot support 2 CAN ports and 2 TTL UART ports at the same time.
- The serial port and CAN port used in the IEM615-1D-1C module are UART1 and CAN1 respectively.

## 1.2 Product Specification

<b>Port</b>	
100M copper port	10/100Base-T(X), automatic flow control, full/half duplex mode, MDI/MDI-X autotuning
100M fiber port	100Base-FX
CONSOLE port	CLI command line management port
I/O port	Alarm input and output
TTL UART port	Port type: TTL level, which can be expanded into RS-232/RS-485/RS-422 Baud rate: 300bps-115200bps
TTL CAN port	Baud rate: 5kbps-1000kbps
<b>Exchange Properties</b>	
Backplane bandwidth	1.2G
Packet buffer size	0.5Mbit
MAC table size	2K
<b>Power Supply</b>	
Input power supply	3.3VDC (±5%)
<b>Consumption</b>	
Full-load consumption	<1.5W
<b>Environmental Limit</b>	
Operating temperature	-40~75°C
Storage temperature	-40~85°C
Operating humidity	5%~95%
<b>Physical Characteristics</b>	
Installation	Embedded installation (insertion form of pin header and female header)
Size (W×H×D):	55mm×9.7mm×40mm



# 2 Dimension

## 2.1 Package Design

The module structure chart as follows:

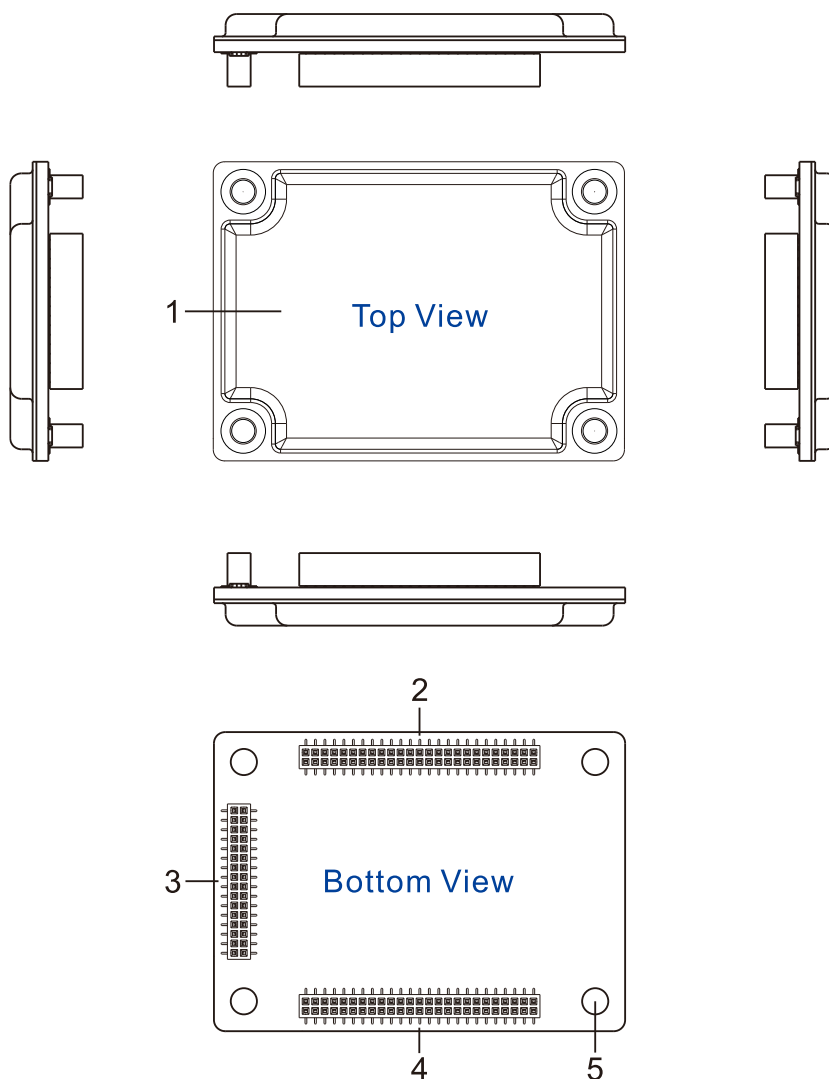

Detailed description of each package label is shown in the following table:

Package	Name	Specification	Description
1	Shielding case	55mm*40mm	It can be connected to cooling fin.
2	Female header C	Female header 2*25, pin spacing 1.27mm, height of female header 4.3mm, square hole 0.4mm*0.4mm	-
3	Female header B	Female header 2*16, pin spacing 1.27mm, height of female header 4.3mm, square hole 0.4mm*0.4mm	-
4	Female header A	Female header 2*25, pin spacing 1.27mm, height of female header 4.3mm, square hole 0.4mm*0.4mm	-
5	Location hole	The diameter of the location mounting hole is $3.1\pm 0.15\text{mm}$ , which is suitable for M3 screw. The distance from the center of the circle to the four sides of the PCB board is 4mm. Notes: Copper post can be used to fix the module on the backplane.	4 location holes are in the same size.

Refer to the following view for the specification of corresponding pin header of the female header B. Unit: mm

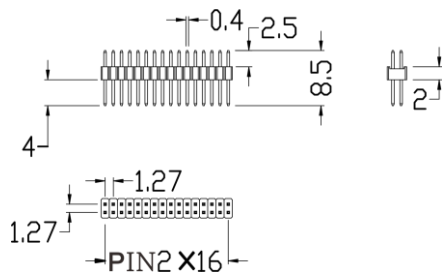

Refer to the following view for the specification of corresponding pin header of the female header A and C. Unit: mm

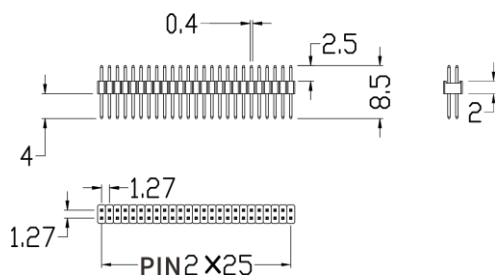

## 2.2 Product Dimension

Structure chart of the module as follows:

Unit: mm



Notice

The diameter of the location mounting hole is  $3.1 \pm 0.15$ mm, which is suitable for M3 screw.

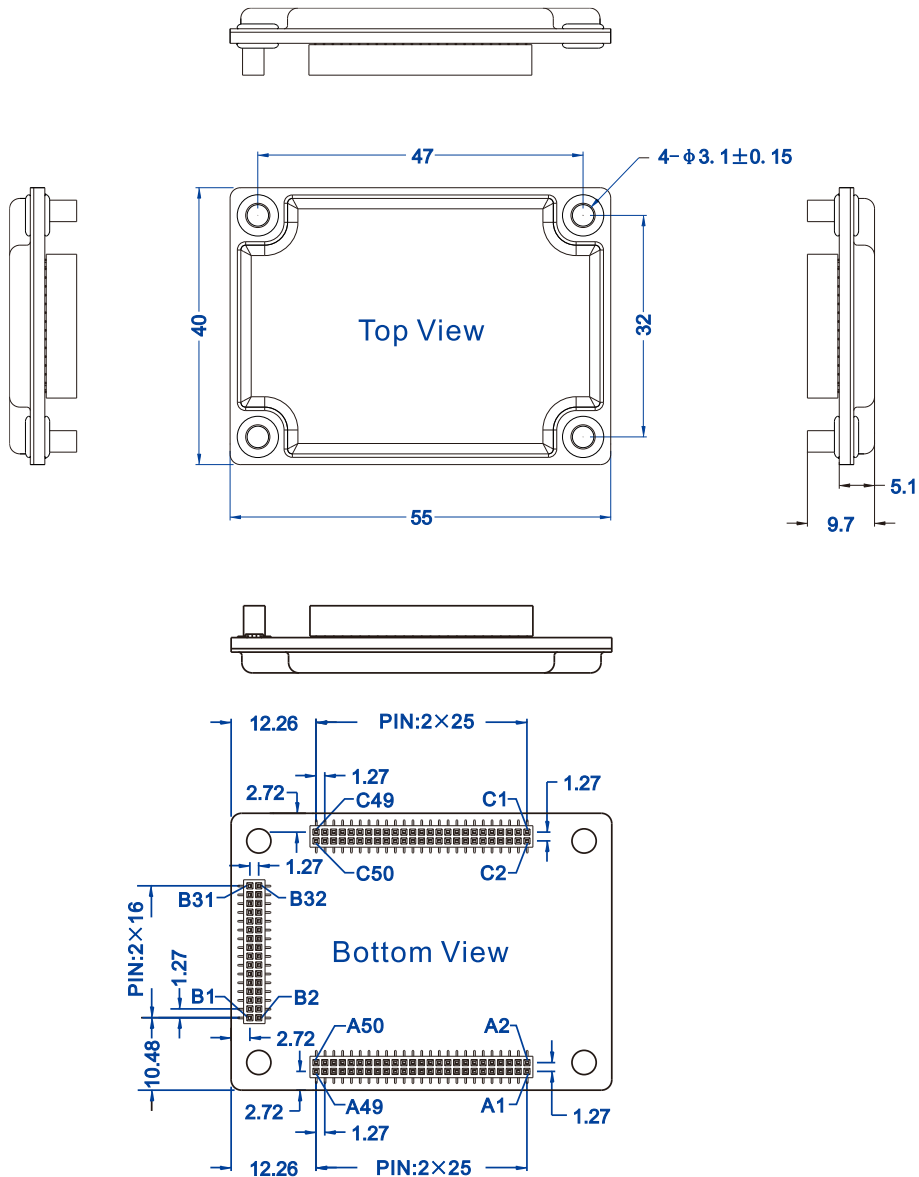

# 3 Description of Pin Definition

---

## 3.1 View of Pin Definition

---



To facilitate the user to view the pin definition when routing the PCB (printed circuit board), the pin definition diagram adopts top view angle as shown below.

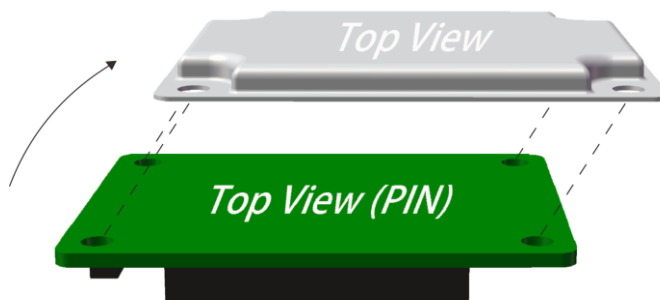

---

The top view of the module pin number and name as follows:

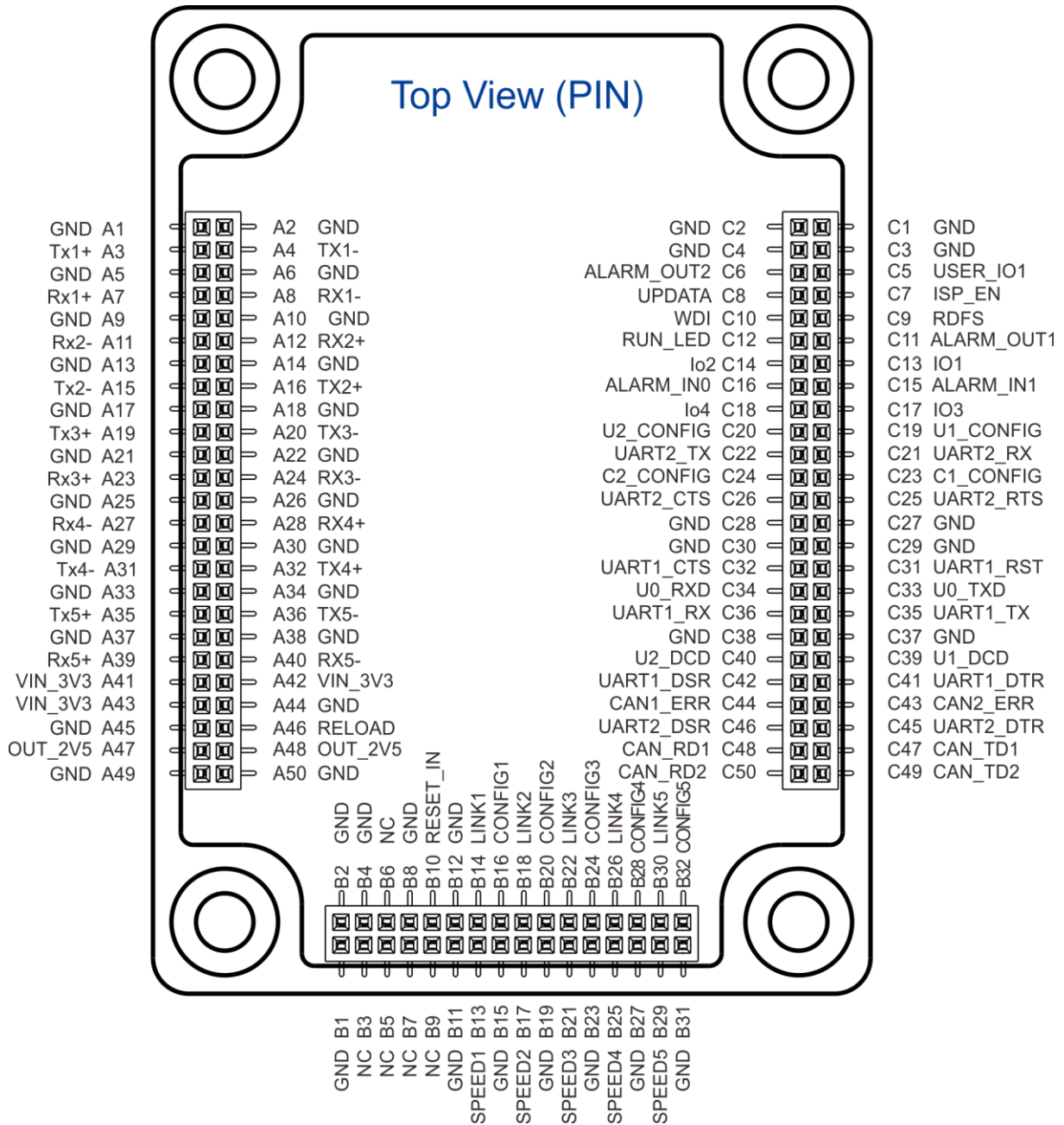

## 3.2 Description of Pin Definition Name

Pin Identification	Description
GND	Ground
RX	Receive Data
TX	Transmit Data
VIN_3V3	VIN: Voltage Input 3V3: 3.3VDC
OUT_2V5	OUT:Output

Pin Identification	Description
	2V5: 2.5VDC
NC	No Connected
OUT	Output
IN	Input
IO	Input/Output
ISP_EN	ISP: In System Program EN: Enable
WDI	Watch Dog Input
RDFS	Restore Default Factory Settings
LED	Light Emitting Diode
U_CONFIG	UART_CONFIG, serial port configuration
UART	Universal Asynchronous Receiver/Transmitter
C_CONFIG	CAN_CONFIG, CAN port configuration
CAN	Controller Area Network, CAN Port
CTS	Clear to Send
RTS	Request to Send
RXD	Receive Data
TXD	Transmit Data
DCD	Data Carrier Detect
DSR	Data Set Ready
DTR	Data Terminal Ready
ERR	Error
CAN_RD	CAN: Controller Area Network, CAN Port RD: Receive Data
CAN_TD	CAN: Controller Area Network, CAN Port TD: Transmit Data

### 3.3 List of Pin Definition

#### Pin definition of female header A (JP1) (A1-A50)

Pin No.	Pin Name	Pin No.	Pin Name
A1	GND	A2	GND
A3	TX1	A4	TX1-

Pin No.	Pin Name	Pin No.	Pin Name
A5	GND	A6	GND
A7	RX1+	A8	RX1-
A9	GND	A10	GND
A11	RX2-	A12	RX2+
A13	GND	A14	GND
A15	TX2-	A16	TX2+
A17	GND	A18	GND
A19	TX3+	A20	TX3-
A21	GND	A22	GND
A23	RX3+	A24	RX3-
A25	GND	A26	GND
A27	RX4-	A28	RX4+
A29	GND	A30	GND
A31	TX4-	A32	TX4+
A33	GND	A34	GND
A35	TX5+	A36	TX5-
A37	GND	A38	GND
A39	RX5+	A40	RX5-
A41	VIN_3V3	A42	VIN_3V3
A43	VIN_3V3	A44	GND
A45	GND	A46	RELOAD
A47	OUT_2V5	A48	OUT_2V5
A49	GND	A50	GND

### Pin definition of female header B (JP2) (B1-B32)

Pin No.	Pin Name	Pin No.	Pin Name
B1	GND	B2	GND
B3	NC	B4	GND
B5	NC	B6	NC
B7	NC	B8	GND
B9	NC	B10	RESET_IN
B11	GND	B12	GND
B13	SPEED1	B14	LINK1
B15	GND	B16	CONFIG1

Pin No.	Pin Name	Pin No.	Pin Name
B17	SPEED2	B18	LINK2
B19	GND	B20	CONFIG2
B21	SPEED3	B22	LINK3
B23	GND	B24	CONFIG3
B25	SPEED4	B26	LINK4
B27	GND	B28	CONFIG4
B29	SPEED5	B30	LINK5
B31	GND	B32	CONFIG5

### Pin definition for female header C (JP3) (C1-C50)

Pin No.	Pin Name	Pin No.	Pin Name
C1	GND	C2	GND
C3	GND	C4	GND
C5	USER_IO1	C6	ALARM_OUT2
C7	ISP_EN	C8	UPDATA
C9	RDFS	C10	WDI
C11	ALARM_OUT1	C12	RUN_LED
C13	IO1	C14	IO2
C15	ALARM_IN1	C16	ALARM_IN0
C17	IO3	C18	IO4
C19	U1_CONFIG	C20	U2_CONFIG
C21	UART2_RX	C22	UART2_TX
C23	C1_CONFIG	C24	C2_CONFIG
C25	UART2_RTS	C26	UART2_CTS
C27	GND	C28	GND
C29	GND	C30	GND
C31	UART1_RST	C32	UART1_CTS
C33	U0_TXD	C34	U0_RXD
C35	UART1_TX	C36	UART1_RX
C37	GND	C38	GND
C39	U1_DCD	C40	U2_DCD
C41	UART1_DTR	C42	UART1_DSR
C43	CAN2_ERR	C44	CAN1_ERR
C45	UART2_DTR	C46	UART2_DSR



Pin No.	Pin Name	Pin No.	Pin Name
C47	CAN_TD1	C48	CAN_RD1
C49	CAN_TD2	C50	CAN_RD2

## 3.4 Detailed Description of the Pin Definition

### 3.4.1 100M Ethernet Port

Pin definition description of 5 100M Ethernet ports:

Pin Name	Pin No.	Type	Functional Description
RX1+	A7	Input	Positive terminal of data receiving of 100M Ethernet port. <ul style="list-style-type: none"> <li>When 100M Ethernet ports 1-5 are configured as 100M copper ports, RX+[1:5] is directly connected to the network transformer.</li> <li>When 100M Ethernet ports 1-5 are configured as 100M fiber ports, RX+[1:5] is directly connected to the positive output terminal of the optical module.</li> <li>It is recommended to keep the pin reserved when it's not used.</li> </ul>
RX2+	A12		
RX3+	A23		
RX4+	A28		
RX5+	A39		
RX1-	A8	Input	Negative terminal of data receiving of 100M Ethernet port. <ul style="list-style-type: none"> <li>When 100M Ethernet ports 1-5 are configured as 100M copper ports, RX-[1:5] is directly connected to the network transformer.</li> <li>When 100M Ethernet ports 1-5 are configured as 100M fiber ports, RX-[1:5] is directly connected to the negative output terminal of the fiber receiver.</li> <li>It is recommended to keep the pin reserved when it's not used.</li> </ul>
RX2-	A11		
RX3-	A24		
RX4-	A27		
RX5-	A40		
TX1+	A3	Output	Positive terminal of data sending of 100M Ethernet port.
TX2+	A16		

Pin Name	Pin No.	Type	Functional Description
TX3+	A19		<ul style="list-style-type: none"> <li>When 100M Ethernet ports 1-5 are configured as 100M copper ports, TX+[1:5] is directly connected to the network transformer.</li> <li>When 100M Ethernet ports 1-5 are configured as 100M fiber ports, TX+[1:5] is directly connected to the positive input terminal of the optical module.</li> <li>It is recommended to keep the pin reserved when it's not used.</li> </ul>
TX4+	A32		
TX5+	A35		
TX1-	A4	Output	<p>Negative terminal of data sending of 100M Ethernet port.</p> <ul style="list-style-type: none"> <li>When 100M Ethernet ports 1-5 are configured as 100M copper ports, TX-[1:5] is directly connected to the network transformer.</li> <li>When 100M Ethernet ports 1-5 are configured as 100M fiber ports, TX-[1:5] is directly connected to the negative input terminal of the optical module.</li> <li>It is recommended to keep the pin reserved when it's not used.</li> </ul>
TX2-	A15		
TX3-	A20		
TX4-	A31		
TX5-	A36		
CONFIG1	B16	Input	<p>Pins configuration of 100M Ethernet ports.</p> <ul style="list-style-type: none"> <li>When CONFIG[1:5] is grounded, corresponding 100M Ethernet ports 1-5 are configured as 100M copper ports.</li> <li>When CONFIG[1:5] is connected to the +3.3VDC power supply through a 4.7kΩ resistor, corresponding 100M Ethernet ports 1-5 are configured as 100M fiber ports.</li> <li>The pin is recommended to be grounded when it's not used.</li> </ul>
CONFIG2	B20		
CONFIG3	B24		
CONFIG4	B28		
CONFIG5	B32		

### 3.4.2 Power Supply and Ground Signal

Pin definition description of power supply and ground signal:

Pin Name	Pin No.	Type	Functional Description
VIN_3V3	A41, A42, A43	Input	3.3VDC voltage input, it provides power supply for the module.
OUT_2V5	A47, A48	Output	2.5VDC voltage output, it's used for the centre tap of the Ethernet port network transformer and can't be used for other purposes.
GND	A1, A2, A5, A6, A9, A10, A13, A14, A17, A18, A21, A22, A25, A26, A29, A30, A33, A34, A37, A38, A44, A45, A49, A50, B1 B2, B4, B8, B11, B12, B15, B19, B23, B27, B31, C1, C2, C3, C4, C27, C28, C29, C30, C37, C38	Ground	Ground signal

### 3.4.3 TTL UART Interface

The TTL UART could be extended to RS-232/RS-485/RS-422 serial port.

The description of 2-way TTL UART pin definition:

Pin Name	Pin No.	Type	Function Description
UART1_RX	C36	Input	UART1 Received signal
UART1_TX	C35	Output	UART1 Transmitted signal
UART1_RTS	C31	Output	UART1 Request to Send signal Note: When UART1 is extended to RS-485/422 serial port, this pin receives/sends enablement as

Pin Name	Pin No.	Type	Function Description
			RS-485.
UART1_CTS	C32	Input	UART1 Clear to Send signal
UART1_DTR	C41	Output	UART1 Data Terminal Ready signal
UART1_DSR	C42	Input	UART1 Data Send Ready signal
UART2_RX	C21	Input	UART2 Received signal
UART2_TX	C22	Output	UART2 Transmitted signal
UART2_RTS	C25	Output	UART2 Request to Send signal Note: When UART2 is extended to RS-485/422 serial port, this pin receives/sends enablement as RS-485.
UART2_CTS	C26	Input	UART2 Clear to Send signal
UART2_DTR	C45	Output	UART2 Data Terminal Ready signal
UART2_DSR	C46	Input	UART2 Data Send Ready signal
U1_DCD	C39	Input	UART1 Data Carrier Detect signal
U2_DCD	C40	Input	UART2 Data Carrier Detect signal

### 3.4.4 TTL CAN Port

The description of 2-way TTL CAN port pin definition:

Pin Name	Pin No.	Type	Function Description
CAN_TD1	C47	Output	CAN1 Transmitted signal
CAN_RD1	C48	Input	CAN1 Received signal
CAN_TD2	C49	Output	CAN2 Transmitted signal
CAN_RD2	C50	Input	CAN2 Received signal

### 3.4.5 CONSOLE Port (Debugging Port)

The description of CONSOLE port pin definition:

Pin Name	Pin No.	Type	Function Description
U0_RXD	C34	Input	UART0 Received signal, used for CONSOLE port to debug this module only.
U0_TXD	C33	Output	UART0 Transmitted signal, used for

Pin Name	Pin No.	Type	Function Description
			CONSOLE port to debug this module only.

### 3.4.6 I/O Alarm Interface

The description of I/O alarm interface pin definition:

Pin Name	Pin No.	Type	Function Description
ALARM_OUT2	C6	Output	The pin of 2-way alarm signal output. It corresponds to the status of 2-way alarm signal input. When the status of any one input changes, so do the two outputs. <ul style="list-style-type: none"> <li>ALARM_OUT1 could be extended to relay. Active low level.</li> <li>ALARM_OUT2 could be extended to alarm indicator. Active low level.</li> </ul>
ALARM_OUT1	C11		
ALARM_IN0	C16	Input	The pin of 2-way alarm signal input. It could configure alarm input type on its own, such as power alarm information detection. Active-high level range is 2.7~3.5VDC.
ALARM_IN1	C15		

### 3.4.7 Indicator

The description of indicator pin definition:

Pin Name	Pin No.	Type	Function Description
CPU_RUN	C12	Output	The pin of running indication signal output.
CAN1_ERR	C44	Output	CAN1 error indicator, Active low level.
CAN2_ERR	C43	Output	CAN2 error indicator, Active low level.
LINK1	B14	Output	100M Ethernet port connection and data transmission indication pin LINK[1:5]. <ul style="list-style-type: none"> <li>When the pin LINK[1:5] outputs high levels, it means the corresponding 100M Ethernet port 1-5 have no connection.</li> <li>When the pin LINK[1:5] outputs low</li> </ul>
LINK2	B18		
LINK3	B22		
LINK4	B26		
LINK5	B30		

Pin Name	Pin No.	Type	Function Description
			<p>levels, it means the corresponding 100M Ethernet port 1-5 have established connection.</p> <ul style="list-style-type: none"> <li>When the pin LINK[1:5] outputs alternate high and low levels, it means the corresponding 100M Ethernet port 1-5 have data transmission.</li> </ul>
SPEED1	B13	Output	<p>100M Ethernet interface speed indication pin SPEED[1:5].</p> <ul style="list-style-type: none"> <li>When the 100M Ethernet port 1-5 are configured to 10BASE-T, the corresponding pin SPEED[1:5] output high levels.</li> <li>When the 100M Ethernet port 1-5 are configured to 100BASE-TX, the corresponding pin SPEED[1:5] output low levels.</li> </ul>
SPEED2	B17		
SPEED3	B21		
SPEED4	B25		
SPEED5	B29		

### 3.4.8 Other Pins

Pin Name	Pin No.	Type	Function Description
RELOAD	A46	Reserved	This pin isn't used, please suspend it.
RESET_IN	B10	Input	Module reset pin. The system would be in reset status when the duration of low level being input to the pin is larger than 200ms.
USER_IO1	C5	Reserved	This pin isn't used, please suspend it.
ISP_EN	C7	Input	Program upgrade, active low level, it's recommended to raise it up.
UPDATA	C8	Input	Program upgrade, active low level, it's recommended to raise it up. The module samples the signal of this pin when powered on. The module program starts to upgrade when the pin receives low levels.
RDFS	C9	Input	Restore to default factory settings, active low level, it's recommended to raise it up.
WDI	C10	Reserved	This pin isn't used, please suspend it.

Pin Name	Pin No.	Type	Function Description
IO1	C13	Reserved	This pin isn't used, please suspend it.
IO2	C14	Reserved	This pin isn't used, please suspend it.
IO3	C17	Reserved	This pin isn't used, please suspend it.
IO4	C18	Reserved	This pin isn't used, please suspend it.
U1_CONFIG	C19	Reserved	This pin isn't used, please suspend it.
U2_CONFIG	C20	Reserved	This pin isn't used, please suspend it.
C1_CONFIG	C23	Reserved	This pin isn't used, please suspend it.
C2_CONFIG	C24	Reserved	This pin isn't used, please suspend it.

### 3.4.9 Reserved Pins



Pin Name	Pin No.	Type	Function Description
NC	B3, B5, B6, B7, B9	Reserved	This pin isn't used, please suspend it.

# 4 Reference Circuit



Note

The signal identifications in reference circuit are as follows:

- : GND, ground signal;
- : FG, shell protective ground.

## 4.1 100M Ethernet Port

The pin definition of 5-port 100M Ethernet signal and configuration are as follows:

Pin Name	Type	Configuration Method
CONFIG[1:5]	100M Ethernet port type configuration input	100M Ethernet port configuration pin. <ul style="list-style-type: none"> <li>• When CONFIG[1:5] is grounded, the corresponding 100M Ethernet port 1-5 will be configured to 100M copper port.</li> <li>• When CONFIG[1:5] is connected to +3.3VDC power supply through 4.7kΩ resistor, the corresponding 100M Ethernet port 1-5 will be configured to 100M fiber port.</li> <li>• When the pin is not used, it's recommended to be grounded.</li> </ul>
RX+[1:5]	The positive input end of data receiving	
RX-[1:5]	The negative input end of data receiving	
TX+[1:5]	The positive output end of data transmission	
TX-[1:5]	The negative output end of data transmission	



## Reference Circuit for 100M Copper Port

The network transformer in the picture of 100M copper port reference circuit is 1:1 network transformer. The recommended model is H1102 or other compatible products. The central tap of the network transformer needs to connect to the pins of the module, such as A47, A48, etc., which provide +2.5V level.

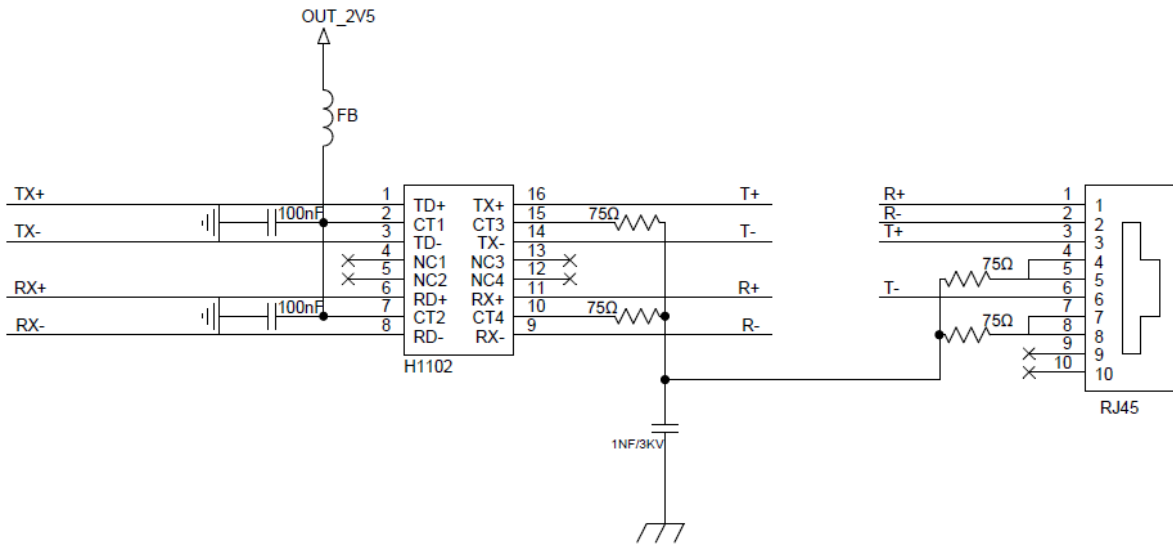

## Reference Circuit for 100M Fiber Port

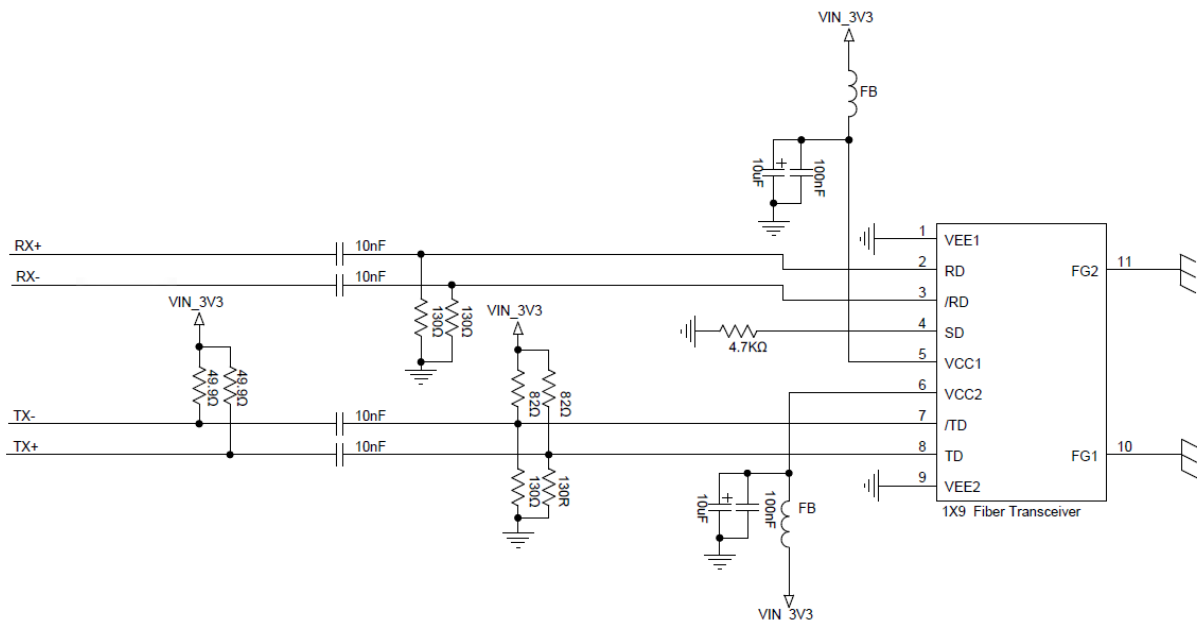

## 4.2 TTL UART Port

This module has 2 TTL UART ports which could be configured to RS-232, RS-485/422 and other communication modes. Each communication mode has given reference circuit and description information, so user can configure communication mode based on the requirement.

Pin Name	Type	Configuration Method
UART_RX[1:2]	Input	UART1-2 Received signal
UART_TX[1:2]	Output	UART1-2 Transmitted signal
UART_CTS[1:2]	Input	UART1-2 Clear to Send signal
UART_RTS[1:2]	Output	UART1-2 Request to Send signal
UART_DSR[1:2]	Input	UART1-2 Data Send Ready signal
UART_DTR[1:2]	Output	UART1-2 Data Terminal Ready signal
U_DCD[1:2]	Input	UART1-2 Data Carrier Detect signal

### Reference Circuit for RS-232

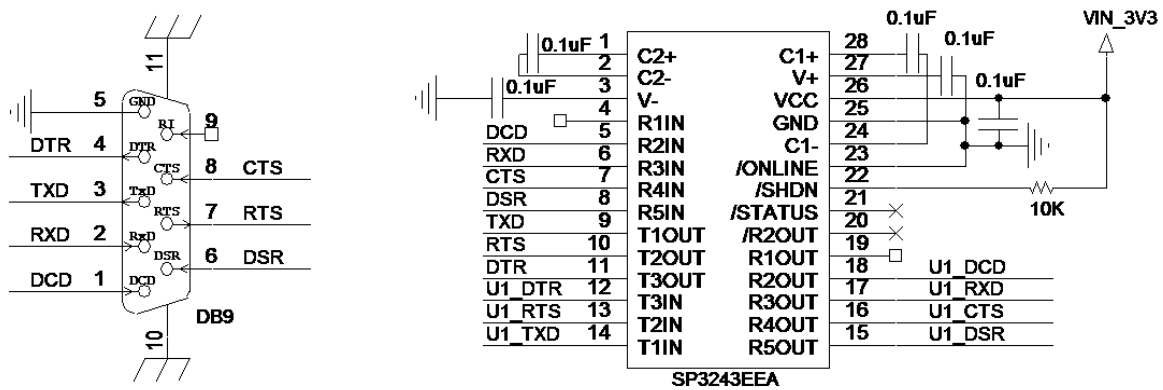

### Reference Circuit for RS-485 (Two-wire System)

The connection method of RS-485 two-wire system adopts half-duplex communication method; its bus type topology structure enables it to connect up to 32 nodes on one bus. It usually adopts master-slave communication mode in RS-485 communication network, which is one master with multiple slaves. RS-485 transmits signal in differential mode.

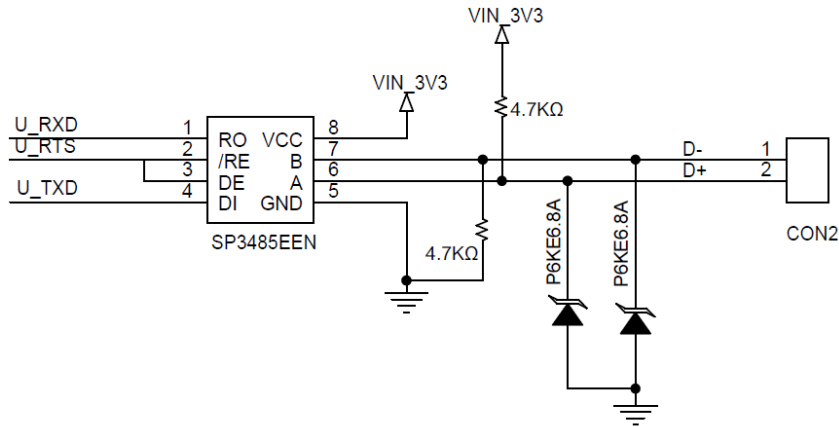

### Reference Circuit for RS-485 (Two-wire System) with Isolation

Isolated power supply:

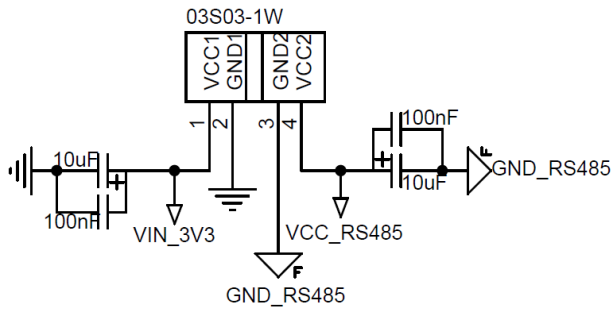

Signal isolation:

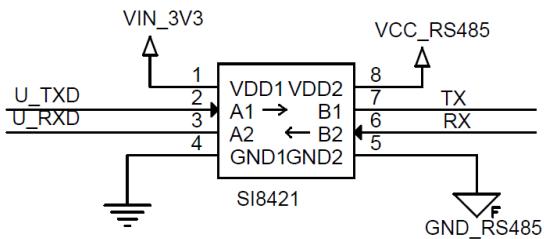

Automatic direction control circuit:

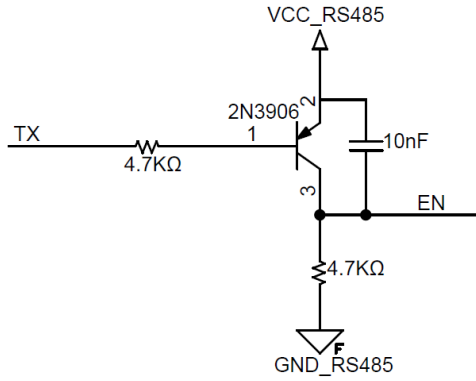

Serial to RS-485 circuit:

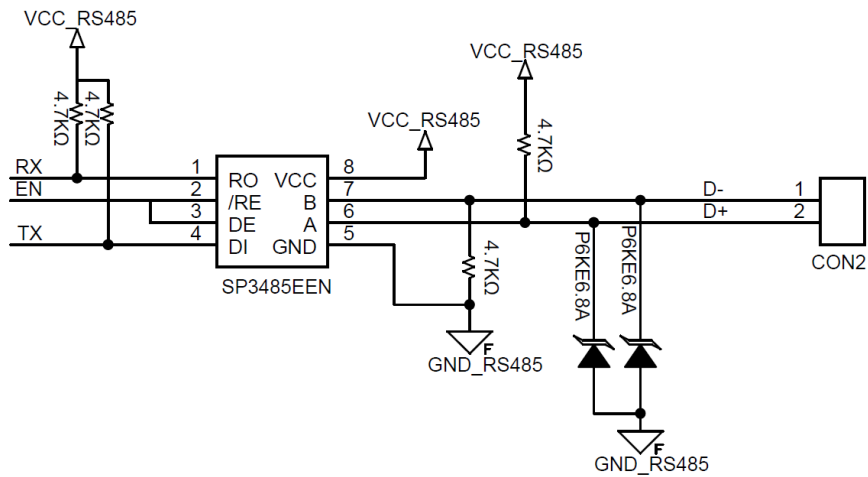

## Reference Circuit for RS-422

The connection method of RS-422 four-wire system adopts full-duplex communication method, which can realize point-to-multipoint communication.

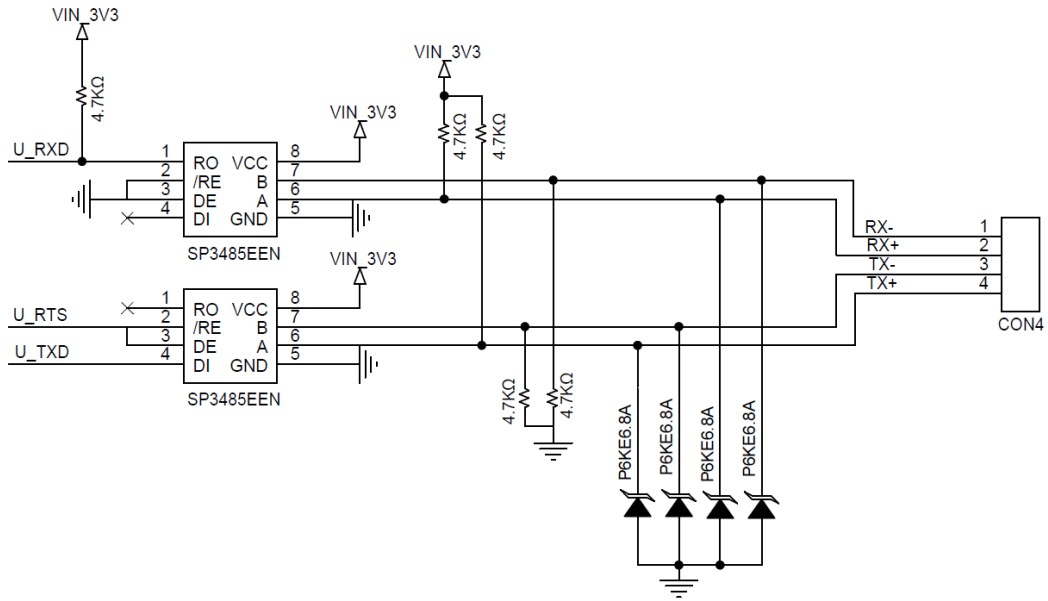

### 4.3 TTL CAN Port

The module has two CAN bus ports. The bus can connect 128 contacts.

Pin Name	Type	Configuration Method
CAN_TD[1:2]	Output	CAN Transmitted signal
CAN_RD[1:2]	Input	CAN Received signal
CAN1_ERR	Output	CAN Error indicator.
CAN2_ERR	Output	Active low level

### Reference Circuit for CAN

The CAN bus connects to the physical bus via CANH and CANL, the two output ends of CAN transceiver interface chip A82C250. The status of CANH end can only be high level or suspension, and the status of CANL end can only be low level or suspension. Due to their different level properties, a terminal resistor needs to be added at the terminal of CAN.

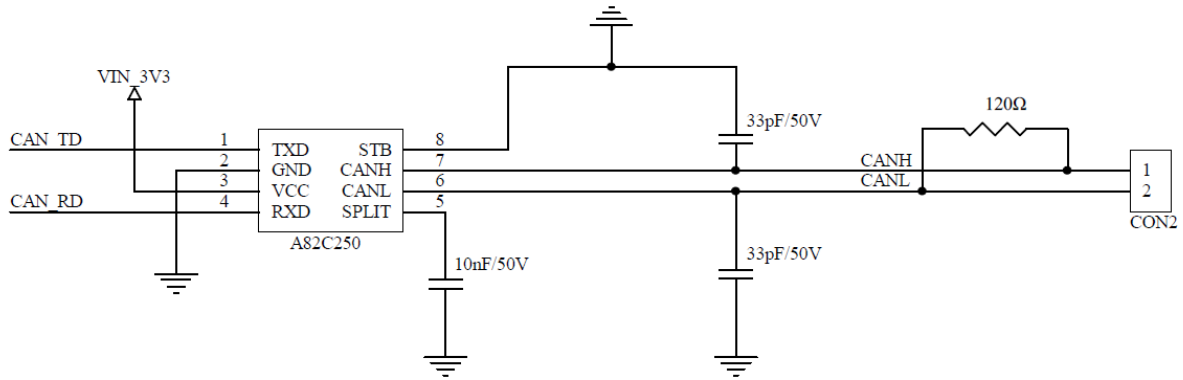

## 4.4 CONSOLE Port (Debugging Port)

As the CONSOLE port of this module, the UART0 debugging port is used for building CLI management platform.

Pin Name	Pin No.	Type	Function Description
U0_RXD	C34	Input	UART0 received signal, merely used for CONSOLE port to debug this module.
U0_TXD	C33	Output	UART0 transmitted signal, merely used for CONSOLE port to debug this module.

## Reference Circuit for CONSOLE Port

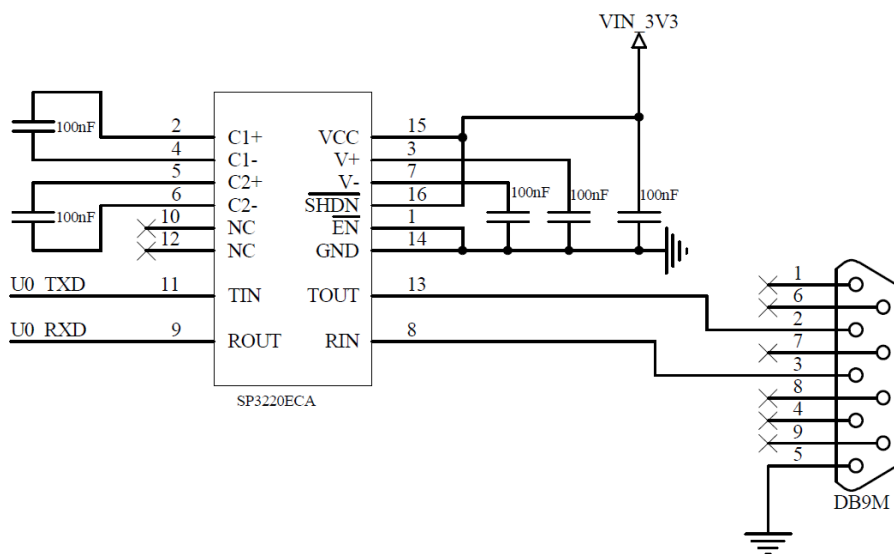

## 4.5 I/O Alarm Interface

The module has 2 alarm signal inputs whose type can be self-configured, and 2 alarm signal outputs which could be used for relay alarm output. Active low level.

Pin Name	Type	Configuration Method
ALARM_IN[0:1]	Input	2 alarm signal input pins. Its type can be self-configured to low/high level alarm.
ALARM_OUT1	Output	Relay alarm output, low level alarm.
ALARM_OUT2	Output	Alarm signal output pin. Active low level.

### Reference Circuit for Relay Alarm

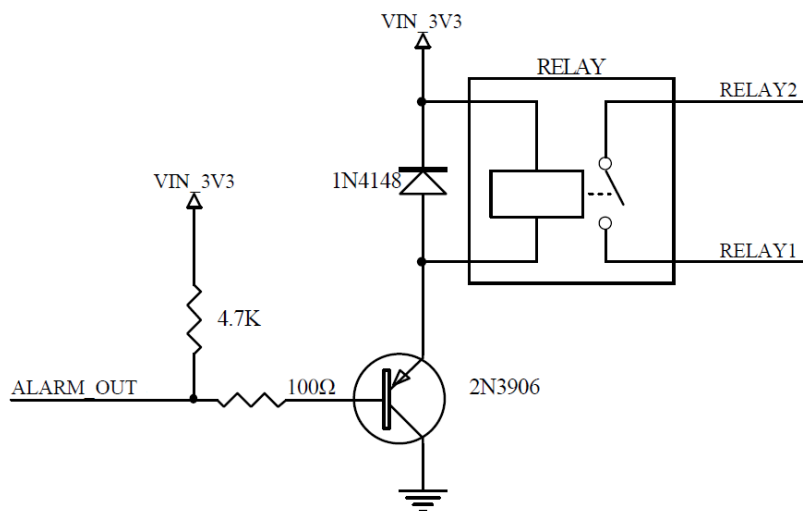

## 4.6 Reset Interface

The module provides external pin for manual reset input which can implement manual reset through designing external hardware reset circuit.

Pin Name	Type	Configuration Method
RESET_IN	Input	Module reset pin. The system would be in reset status when the duration of low level being input to the pin is larger than 200ms.

### Reference Circuit for Reset

**3onedata**  
Make network communication more reliable



**3onedata Co., Ltd.**

Headquarter address: 3/B, Zone 1, Baiwangxin High Technology Industrial Park, Song Bai Road,  
Nanshan District, Shenzhen

Technology support: [tech-support@3onedata.com](mailto:tech-support@3onedata.com)

Service hotline: +86-400-880-4496

Official Website: <http://www.3onedata.com>