



# Product Guide

Comprehensive Network Transmission Infrastructure Innovations



# Contents



## 01 Network Management

- 2 Network Management System Solution
- 3 PLANET Cloud-based Monitoring App
- 4 Centralized Management Controller
- 5 Intelligent Renewable Energy Management Controller

## 06 LAN Switches

- 9 Layer 3 Managed Chassis Switches
- 10 10G/40G/100G Fiber Managed Switches
- 11 Layer 3 Enterprise Stackable Managed Switches
- 12 10G Layer 3 Managed Gigabit Switches
- 12 Layer 3/2+ IPv6 Managed Metro Switches
- 13 10G Layer 3 IPv6 Managed Gigabit Switches
- 13 Multigigabit L3 IPv6 Managed PoE Switches
- 14 Touch LCD 10G Layer 3 IPv6 Managed Gigabit Switches
- 14 Layer 2+ IPv6 Managed Gigabit Switches
- 15 Layer 2/4 IPv4/IPv6 Managed Gigabit Switches
- 16 Layer 2/4 IPv6 Desktop-size Managed Gigabit Switches
- 16 Web Smart Ethernet Switch
- 17 Layer 2 Unmanaged Gigabit Switches
- 17 Layer 2 Unmanaged Fast Ethernet Switches

## 18 Industrial Ethernet

- 20 Layer 3 and Layer 2 Industrial Managed Gigabit Switches
- 22 Layer 2 Industrial Gigabit Switches
- 23 Layer 2 Industrial Fast Ethernet Switches
- 23 Layer 3 and Layer 2 Industrial Managed Gigabit PoE Switches
- 26 Layer 2 Industrial PoE Switches/Extenders
- 27 EN50155 ITS Ethernet Network Solution
- 28 Layer 3 and Layer 2 Industrial Flat-type Ethernet Switches
- 29 Industrial Flat-type Gigabit Routers
- 29 Renewable Energy PoE Switches & Management Controller Series
- 30 Industrial PoE Injectors & Splitters
- 31 Industrial PoE Media Converters
- 32 Industrial Fiber over Ethernet Media Converters
- 32 Industrial 10GBASE-X Fiber over Ethernet Media Converters
- 33 Industrial 1000BASE-X Fiber over Ethernet Media Converters
- 33 Industrial 100BASE-FX Fiber over Ethernet Media Converters
- 34 Industrial Cellular Gateway
- 36 Vehicle 4G LTE Cellular Wireless Gateway
- 36 DIN-rail Power Supplies

## 37 Industrial Automation

- 39 Industrial EtherCAT Slave IO Module
- 39 Industrial RS232/RS485/RS422 over Ethernet Media Converters
- 40 Industrial RS422/RS485 Modbus Gateway
- 40 Serial over Fast Ethernet Media Converters

## 41 Comprehensive AIoT Communication

- 42 AIoT Application Server
- 42 Industrial LoRaWAN Gateway for 300 Nodes
- 43 LoRa Node Controller
- 43 LoRa Sensor

## 44 Power over Ethernet

- 48 Layer 3 802.3at PoE+ Stackable Managed Switch
- 49 Touch LCD 10G Layer 3 802.3at/bt PoE Managed Gigabit Switches
- 50 10G L3 802.3bt PoE++ Managed Gigabit Switches
- 50 10G L3 802.3at/802.3bt Managed Multigigabit Switches
- 51 10G L3 802.3at PoE+ Managed Gigabit Switches
- 51 L2+ 802.3at PoE+ Managed Gigabit Switches
- 52 L2/L4 802.3at/bt PoE Managed Gigabit Switches
- 53 L2/L4 802.3at PoE+ Managed Switches
- 53 Web Smart Ethernet Switch
- 54 Unmanaged LCD PoE+ Switches
- 55 Industrial Flat-type PoE+ Switches
- 56 Industrial Flat-type Gigabit PoE+ Routers
- 56 Unmanaged PoE+/PoE++ Switches
- 57 Multi-port PoE Injector Hubs
- 59 Single-port PoE Injectors & Splitters
- 61 PoE Extenders
- 62 Long Reach PoE L2/L4 IPv6 Managed Switches
- 63 Long Reach PoE Injectors & Extenders

## 64 Media Conversion

- 66 Managed Media Converter Chassis
- 67 Smart Gigabit Media Converters
- 67 Smart Fast Ethernet Media Converters
- 68 Smart 10Gigabit Media Converters
- 68 Media Converter Chassis



## 64 Media Conversion

- 69 10G Media Managed Converters
- 70 10G Ethernet Media Converter
- 71 Gigabit Managed Media Converters
- 71 Gigabit Media Converters
- 72 Gigabit PoE Media Converters
- 72 Fast Ethernet Media Converters
- 73 VDSL2 Media Converters
- 74 Serial over Ethernet Media Converters
- 75 RS422/RS485 Modbus Gateway
- 75 Video over Fiber Optic Converters

## 76 Broadband Communications

- 78 xPON
- 79 VDSL2 Bridges/Routers

## 80 Wireless LANs

- 82 Wireless AP Management Solution
- 82 Hardware AP Controller
- 84 Software AP Controller
- 84 Enterprise Wi-Fi Networking Solution
- 84 Enterprise Wireless Access Points/Industrial Wireless Access Points
- 85 Outdoor Wireless LAN Solutions
- 86 5GHz and 2.4GHz 802.11ax/ac Wireless Outdoor Solutions
- 86 Wireless Outdoor CPEs
- 87 5G NR/4G LTE Cellular Wireless Gateways
- 88 Wireless Antennas and Cable Accessories

## 89 IP Surveillance

- 91 H.265+ Surveillance
- 92 H.265+ Network Video Recorders
- 93 H.264 IP Cameras
- 93 Network Video Recorders
- 94 Hybrid Digital Video Recorders
- 94 AHD Cameras

## 95 IP Telephony

- 97 SIP IP Conference Phones
- 98 SIP Intercom & Door Phones
- 98 IP PBXs
- 99 SIP VoIP Gateway
- 99 Skype Gateway
- 99 Wireless SIP Router/DECT Phone

## 100 Network Security

- 101 VPN Security Routers / Industrial VPN Security Gateway Series
- 102 Industrial 5G NR/4G LTE Security Gateways
- 102 Industrial Flat-type Routers

## 103 Network Peripherals

- 104 IP KVM
- 104 IP Power Managers
- 105 HDMI/Video Wall over IP Transmitters/Receivers
- 105 Ethernet Adapters
- 106 Digital Media Center/IP Set-Top Box/Multimedia
- 106 Powerline Ethernet Bridges

## 107 Home Automation

- 107 Cloud Home Automation
- 108 SIP Door Phones
- 108 Z-Wave Plus Sensors

# Empowering Future Innovation & Sustainability

PLANET Technology, a global leader in IP-based networking solutions with an independent brand, produces an extensive range of advanced industrial and enterprise networking products. Committed to ESG values and the motto "Shaping Future Networking," PLANET drives innovation with IoT, IIoT, IoV, and AIIoT solutions for intelligent and sustainable networks.

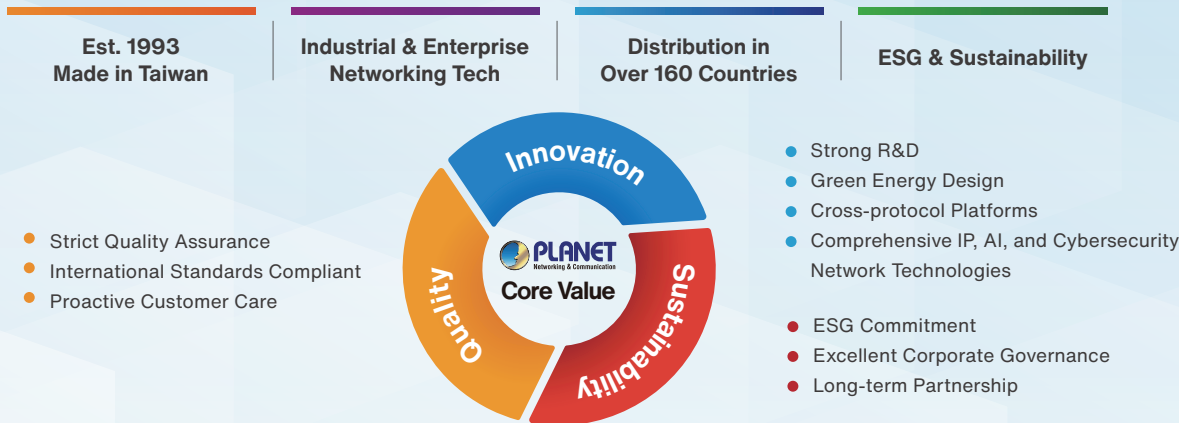

## Building AI & Industrial Network Infrastructure



### Network Infrastructures

- 100Gbps Managed Switches
- 5G IoT Security Gateway
- 95W PoE Devices
- Long Reach PoE/PoC Solutions
- Industrial Ethernet Solutions
- Fiber Optic & Last Mile Solutions
- Renewable Energy PoE Network Solution



### Versatile Network Applications

- Wireless LAN
- 5G Telecom Network
- Network Security
- VoIP
- IP Surveillance



### Intelligent Network Solutions

- Universal Network Management Solution
- Industrial Automation
- Intelligent Transportation System
- Home Automation
- AIIoT Intelligent Network
- Renewable Energy & PoE Network Management
- CloudViewerPro App

## Worldwide Recognitions & Awards



- IoT Application Category Award
- Sustainable Tech Special Award



## Sustainable Corporate Development

PLANET emphasizes corporate social responsibility and ESG sustainable development, integrating these principles into its core business strategy while addressing domestic and international economic, environmental, and social issues.

### ESG Initiatives

- ✓ SBTi Member
- ✓ TCFD Supporter
- ✓ TNFD Adopters
- ✓ Carbon Disclosure Project
- ✓ SME Climate Hub

### Certifications

- ✓ ISO 14067 certified
- ✓ IEC-62443-4-1 certified
- ✓ ISO 27001 certified



- Top 5% of Corporate Governance Evaluation
- Ranked 1st in Excellence in CSR Award
- Forbes Asia's 200 Best Under A Billion
- Asia Responsible Enterprise Awards
- ICSB's Humane Entrepreneurship Award
- Linking ASSET Corporate Humanities Award



NMSViewerPro APP  
CloudViewerPro APP

# Universal Network Management Solution

## Easy Management & Remote Monitoring

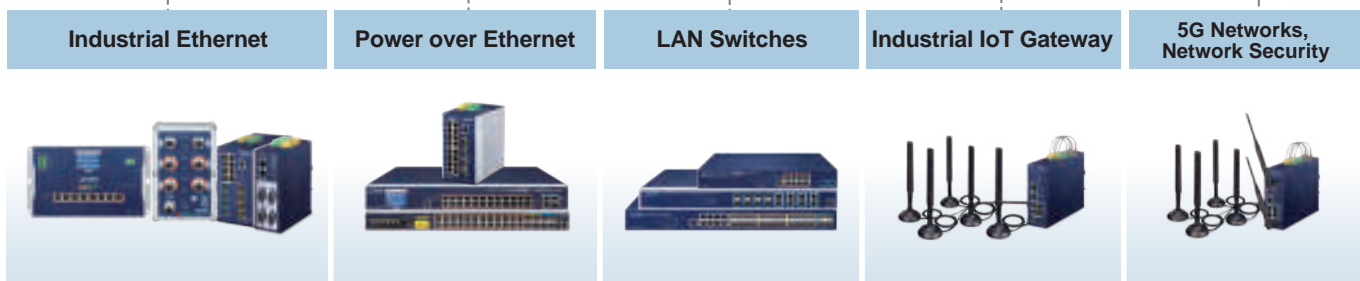

### ➤ Effortlessly Manage Your Access Point with CloudViewerPro App

- Real-time Management
  - Auto Discovery
  - Mobile Control
  - Cloud-based Management
  - Location Setup
  - iOS/Android
- GET IT ON Google Play
 Download on the App Store



# Network Management

## Network Management System Solution

### Smart Central Management Over All Network Devices

PLANET Network Management System (NMS) Solution successfully integrates MQTT, SNMP, ONVIF protocol and PLANET Smart Discovery to enable IT administrators to monitor and further manage up to 10 types of networking devices, covering switches, routers, VoIP, IP Surveillance devices and more.

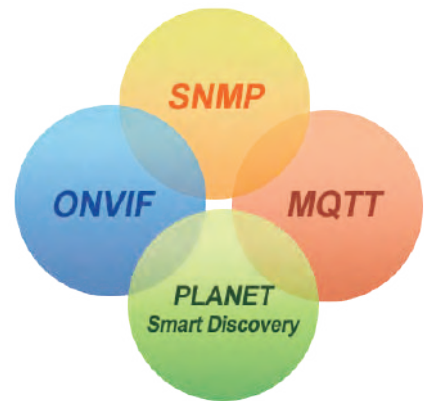

### Economical Central Network Management Solution for SMBs

PLANET Intelligent Network Management System Solution includes the software-based UNI-NMS, hardware-based controller, UNC-NMS, NMS-500, Touch LCD controller, NMS-1000V, and the latest mobile app “CloudViewer” to attend to different applications. PLANET NMS solution features intuitive dashboard, topology and map viewing to make network management efficient and effective.

The exclusive product features for PLANET NMS solution include:

- Centralized control of up to 102,400 nodes
- System upgrade and license (free of charge)
- Intuitive and user-friendly management functions
- Cloud management via PLANET DDNS and Google Map
- 24/7 remote access and management from mobile devices

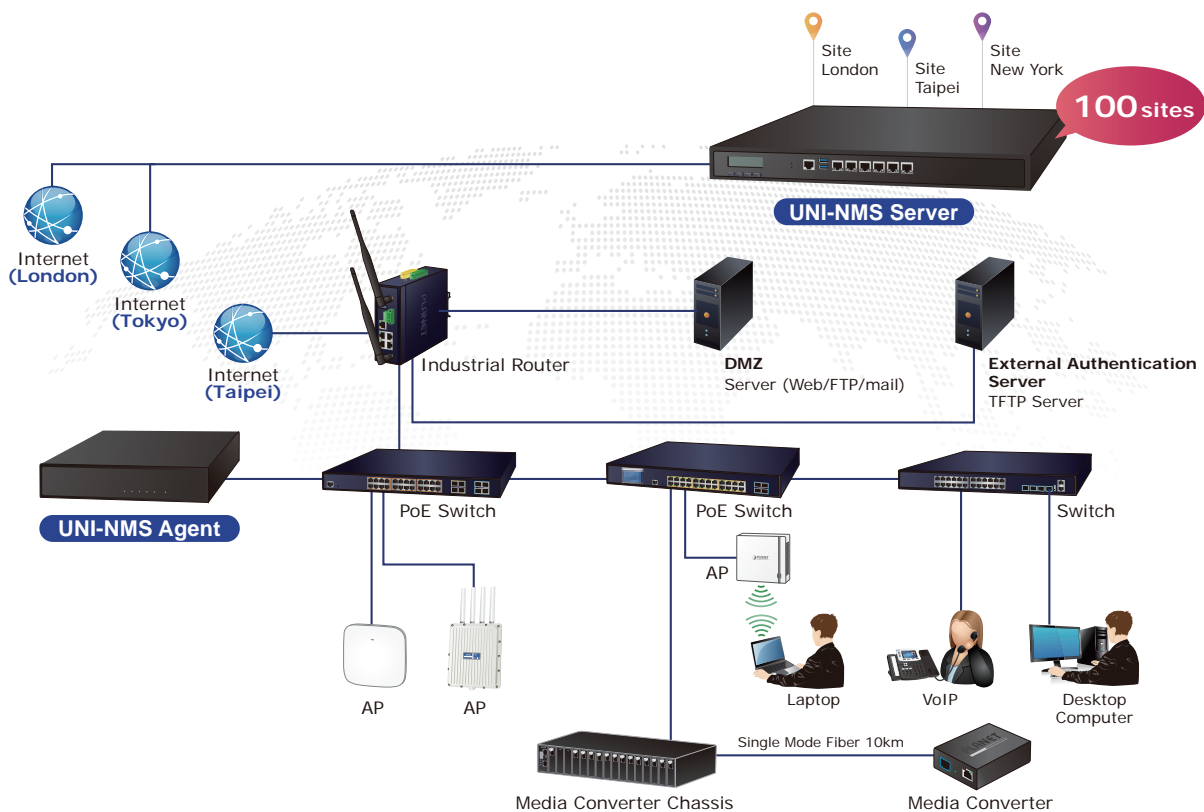

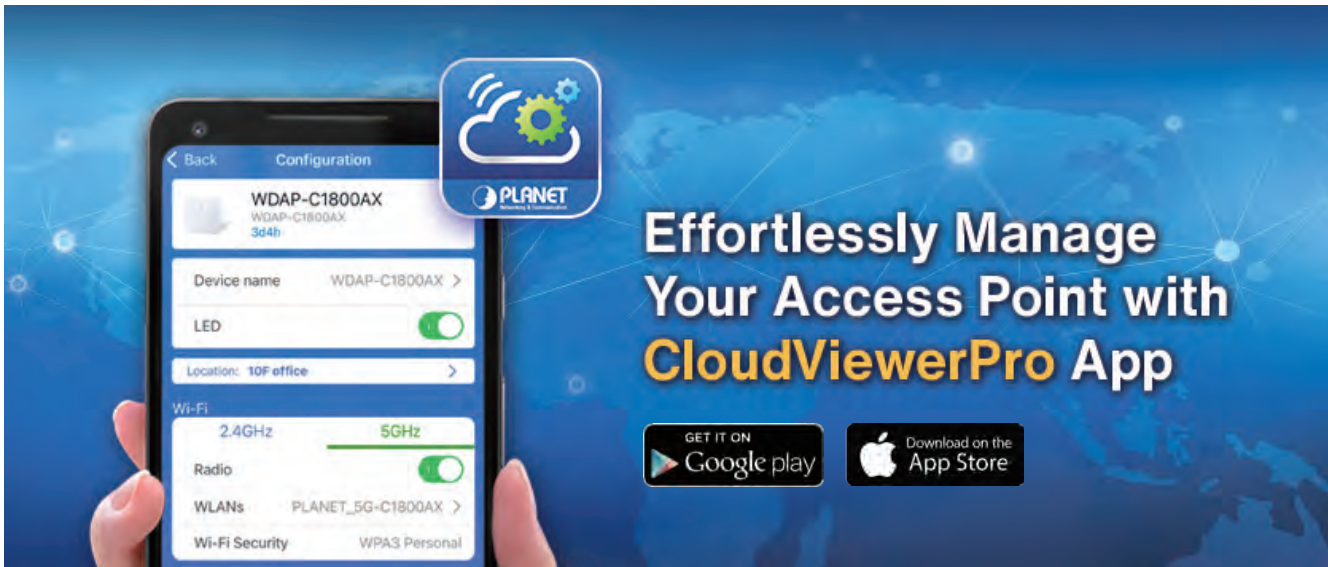

## Intelligent Decentralized Management with PLANET CloudViewerPro App

### Intuitive Mobile User Experience with Cloud Network

PLANET CloudViewerPro is an Intelligent App that manages your network in the cloud. With cloud network, it makes data and services available from anywhere with an Internet connection. With PLANET CloudViewerPro, your network status can be managed in real time anytime, anywhere via your mobile phone or tablet. User can easily check network status, device information, and port and PoE statuses from the cloud to reduce management costs.

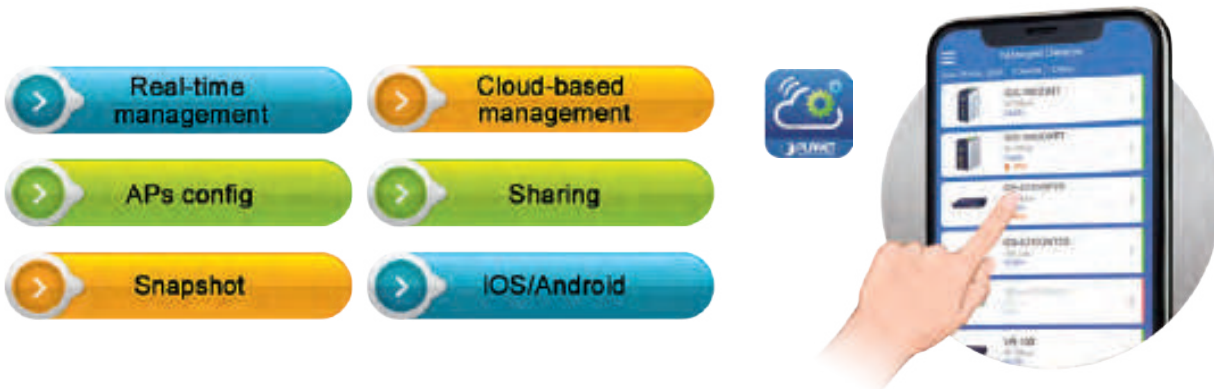

### Sharing Access Authority for Easy Collaboration

Device owners can share their authority of device monitoring with team members via PLANET CloudViewer App. It benefits your shared members by collaborating without complicated account setting and can monitor device anytime, anywhere as device owners.

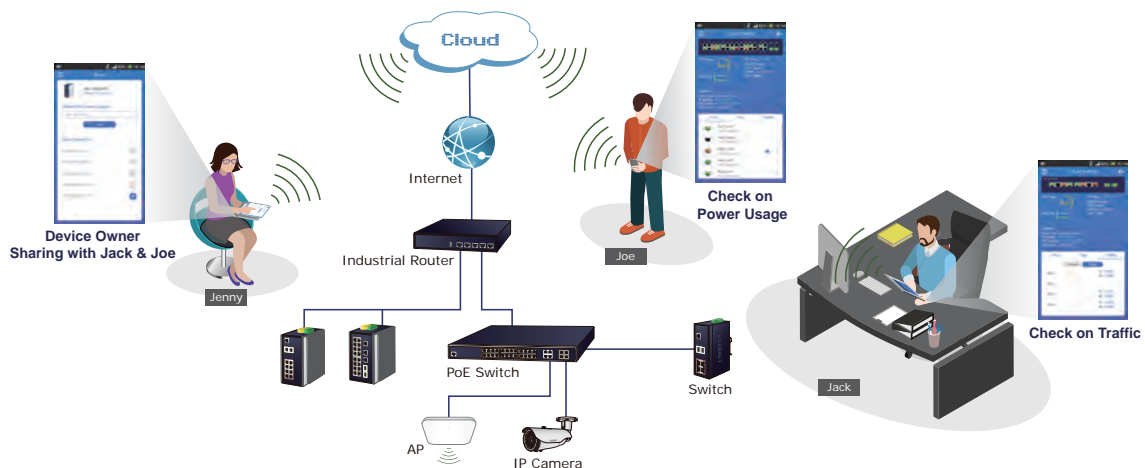

# Centralized Management Controller

PLANET NMS Series Universal Network Management System is integrated in a workstation or PC to monitor all the deployed wired or wireless PoE industrial-grade network devices, such as managed switches, media converters, routers, smart APs, VoIP phones, IP cameras, etc. compliant with the MQTT Protocol, SNMP Protocol, ONVIF Protocol and PLANET Smart Discovery utility. Thus the administrator can centrally manage the network from a central office, greatly boosting network and power management efficiency. With its user authentication management, the NMS Controller enhances data transmission security in the modern factory automation systems. With the touch panel, the NMS-1000V can conveniently help the administrator check the network status right away. If abnormality is detected, the administrator can solve the problem from the central office, without having to go to the actual site.

## Universal Network Management Solution

	Hardware UNC-NMS Controller with LCD		Hardware UNI-NMS Controller	Software UNI-NMS-LITE	Mobile App
Model No./System Name	UNC-NMS	NMS-1000V-12/ NMS-1000V-10	NMS-500	UNI-NMS-Lite (Universal Network Management System)	NMSViewerPro CloudViewerPro

Product Image



		UNC-NMS	NMS-1000V-12/ NMS-1000V-10	NMS-500	UNI-NMS-Lite (Universal Network Management System)	NMSViewerPro CloudViewerPro
Max. Manageable Devices		102,400	1,024	512	100	1,024/512 determined by NMS Agent/256
Resolution		1024 x 768	1024 x 768/1028 x 800	1280 x 1024	1280 x 1024	N/A
HDMI Output		-	●	-	-	-
Extra computer not required		-	●	-	-	●
Cross-domain network		●	●	●	-	●
Dashboard	Interactive Dashboard	●	●	●	●	●
	Multi WAN Traffic History	-	●	●	●	●
	Site Summary & Site Map	●	-	-	-	-
Sites Status Monitoring & Configuration	Online/Offline	●	-	-	-	-
	Site management with import CA	●	-	-	-	-
	Site map Configuration (up to 100 maps)	●	-	-	-	-
Devices Status Monitoring & Configuration	Online/Offline	●	●	●	●	●
	Manual add devices	●	●	●	●	-
	Domain Router Define	●	●	●	●	●
	Switch Virtual Panel with Configuration Function	●	●	●	-	●/-
	Switch per port Traffic and PoE History Graph	●	●	●	-	-
Topology Management	Automatic topology arrangement	●	●	●	●	-
	Site topology selector	●	-	-	-	-
Zero Touch Provisioning	Simple procedure: Rack, connect and power on	●	●	●	●	●
	Topology auto-discovery mechanism	●	●	●	●	-
Fault Management	Grouped alarm monitoring interface, defined according to customer requirements	●	●	●	●	●/-
	Customized alarm filter rules that enable the display of events in order of importance	●1	●1	●1	-	●1/-
	System Event and Syslog daily list	●	●	●	●	●/-
	SMTP Alert (Alert Configuration)	●	●	●	-	-
	Alert Pop Message	●	●	●	-	-
	System Event / Syslog Event Filter	●	●	●	●	●/-
Configuration Management	Real-time status feedback for every device configuration	●	●	●	●	-
	Hyperlink Control	●	●	●	●	-
Performance Management	Uniform performance management system for all devices under management	●	●	●	●	-
	Monitor device CPU, disk and memory utilization	●	●	●	●	-
Statistic Management	Top 10 events	●1	-	-	-	-
	History comparison	●1	-	-	-	-
	Critical events	●1	-	-	-	-
Diagnostics	Ping device IP	●	●	●	●	-
System Backup & Restore	USB Backup\Read Raw Data	●	●	●	-	-
	USB Backup\Restore System Setting Configuration	●	●	●	-	-
Remote WEB client: https, support Edge/Firefox/Chrome/Safari browsers		Firefox/Chrome	Firefox/Chrome	Firefox/Chrome	Firefox/Chrome	-
Site Map / Floor Map		100 (1MBytes x100)	50 (1MBytes x50)	25 (1MBytes x25)	1(1MBytes x10)	-
Built-in DHCP Server		●	●	●	-	-
Built-in RADIUS Server		●	●	●	-	-
PLANET DDNS / Easy DDNS		●/●	●/●	●/●	-	-
AP Control		●	●	●	●	●
Remarks: 1. Future supported through firmware/patch upgrade						Android: 6.0 and above iOS: 13.0 and above



# Intelligent Renewable Energy Management Controller (NMS-360/NMS360V)

PLANET Renewable Energy Management Controller series (NMS-360 Series) is the world's first controller integrating green technology and exclusive intelligent PoE management functions to provide users with real-time remote management over renewable energy usage and connected PD operation status. With PLANET award-winning product, Renewable Energy PoE Switch/Router, BSP-360, the NMS-360 Series provides synchronous information on green power and battery status, instant/average PoE power usage analysis, as well as traffic logs that are compliant with MQTT protocol and PLANET Smart Discovery. The NMS-360 series automatically detects and manages up to 512 BSP-360 devices along with 2048 IP cameras via its user-friendly web UI.

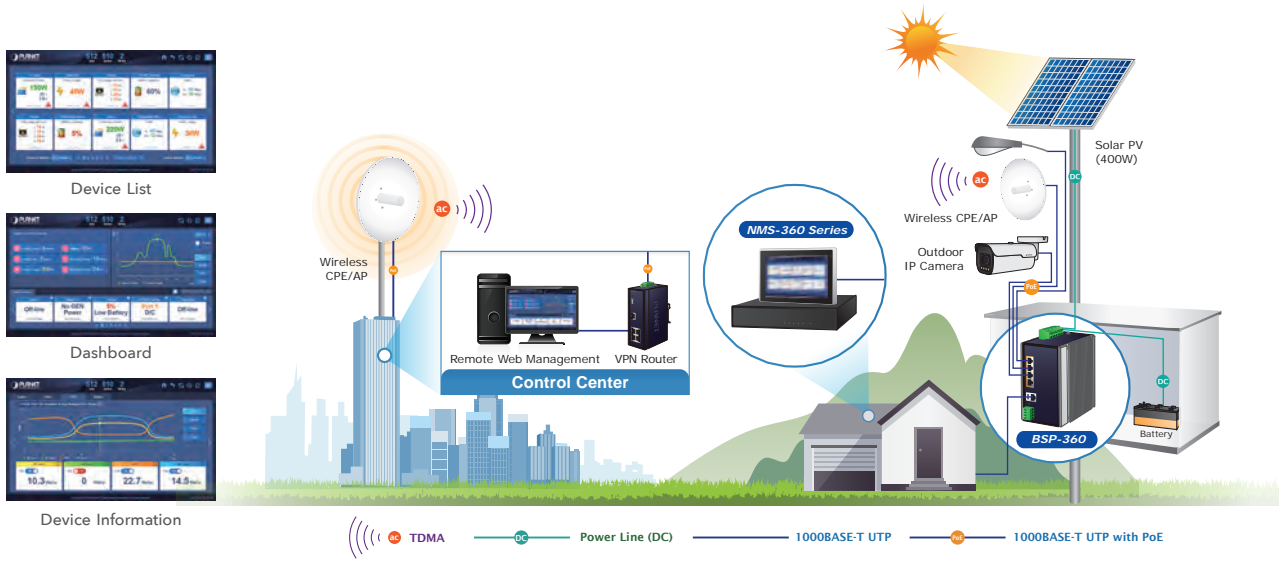

Hardware Interface			
LCD	-	10" Touch Panel	12" Touch Panel
HDMI	-	1 x HDMI	1 x HDMI
GbE Ethernet	5 x GbE LAN RJ-45	2 x GbE LAN RJ-45	2 x GbE LAN RJ-45
USB	Two USB3.0	2 x USB 3.0	2 x USB 3.0
Serial	One RJ45 Console port (COM1)	N/A	N/A
Watt	60W power adaptor (Level 6)	10": 23.7W	12": 29W
Software Feature			
Number of Managed Devices (BSP-360)	512	512	512
Number of IP cameras	2,048	2,048	2,048
Dashboard	•	•	•
Setup Wizard	•	•	•
Node Discovery	•	•	•
App-like Device Viewing	•	•	•
Event Table	•	•	•
Alarm System	•	•	•
Device Provisioning	•	•	•
Site Map	•	•	•
Remote PoE Control	•	•	•
User Control	•	•	•
Scalability	•	•	•
Backup/Restoration/Read	•	•	•
User Account Management	•	•	•
Network Services			
DDNS	Supports PLANET DDNS/Easy DDNS		
DHCP	Built-in DHCP Server for auto IP assignment to APs		
Management	SSL; Web browser (Chrome is recommended);		
Discovery	SNMP v1, v2c, v3		
Standards Conformance			
Regulatory Compliance	CE, FCC		
Standards Compliance	IEEE 802.3 10BASE-T		
	IEEE 802.3u 100BASE-TX		
	IEEE 802.3ab Gigabit 1000BASE-T		



**IP Stacking**  
**Up to 24 Units**



## Layer 3 Enterprise Stackable Switches

» XGS-6350 / SGS-6341 / SGS-6310 Series



Layer 3 24-Port 10G SFP+  
+ 4-Port 100G QSFP28  
Managed Switch  
**XGS-6350-24X4C**



Layer 3 48-Port 10/100/1000T  
802.3at PoE + 6-Port 10G SFP+  
Stackable Managed Switch  
**SGS-6310-48P6XR**



Layer 3 48-Port 10/100/1000T +  
4-Port 10G SFP+ Stackable  
Managed Switch  
**SGS-6341-48T4X**



Layer 3 48-Port 10G SFP+ +  
2-Port 40G QSFP+ + 4-Port  
100G QSFP28 Managed Switch  
**XGS-6350-48X2Q4C**



Layer 3 16-Port 100/1000X SFP +  
8-Port Gigabit TP/SFP + 4-Port 10G  
SFP+ Stackable Managed Switch  
**SGS-6310-16S8C4XR**



Layer 3 24-Port 10/100/1000T  
802.3at PoE + 4-Port 10G SFP+  
Stackable Managed Switch  
**SGS-6341-24P4X**

# LAN Switches

## IPv4 and IPv6 Hardware Layer 3 Routing

Designed for system integrators and SMEs, the Layer 3 series provides not only ultra high transmission performance and excellent Layer 3 technologies, but also IPv4 and IPv6 VLAN routing feature, which allows to get across different VLANs and different IP addresses for the purpose of having a highly-secure, flexible management and simpler networking application.



## Powerful 10Gbps~100Gbps Ultra-high-bandwidth Solution for Big Data System

PLANET's 10Gbps~100Gbps managed switches boast a high-performance switch architecture that is capable of providing non-blocking switch capacity and wire-speed throughput as high as 128Gbps~1.28Tbps. They can handle extremely large amounts of data in a secure topology linking to backbone or high capacity servers where audio, video streaming and multicast applications are utilized, perfectly suitable for data centers, service providers and telecoms to establish high bandwidth for Big Data server farm.

## User-friendly Management with Unique LCD Touch Screen

Aiming to promote the management efficiency in large-scale networks, PLANET provides world's first Color Touch LCD Ethernet Switch that offers quick installation, real-time monitoring of data transmission and PoE work status, and immediate troubleshooting through its unique LCD display found on the front panel. This cutting-edge Plug and Watch Ethernet solution makes the operation of the LCD Ethernet Switch simple for SMBs, enterprises, warehouses, factories, hotels, government buildings, and other public areas to manage their networks.



## Efficient Single IP Management

PLANET stackable switch series applies the advantage of the stacking technology to managing the stack group with one single IP address, which helps network managers to easily manage a stack of switches instead of connecting and setting each unit one by one. It provides IP Stacking function to configure up to a total of 24 switches with up to 16 switches stacked up.

# Build a High Computing Power Data Center

## DCS-7342 Series



PLANET DCS-7342 series, equipped with 10G/25G SFP28 ports and 40G/100G QSFP28 ports, ensures seamless data transmission, enabling the network to operate efficiently even under the heaviest workloads. Whether managing big data, AI processing, or advanced cloud applications, these switches deliver the high bandwidth and stability required to maintain smooth operations.

The DCS-7342 series is engineered for resilience. It incorporates MLAG (Multi-Chassis Link Aggregation), enabling synchronization between paired switches to prevent downtime and ensure high availability. Furthermore, with support for VXLAN (Virtual Extensible LAN), this series facilitates advanced Layer 2 and Layer 3 switching, offering the flexibility to efficiently manage and connect VLANs across multiple locations.

Ideal for high-demand environments such as AI-powered data centers, cloud computing infrastructures, and enterprise-level IT operations, the PLANET L3 Multiport QSFP28 Managed Data Center Switch Series provides the scalability, reliability, and performance that networks require.

### DCS-7342-32C2X

- 100G QSFP28 port x 32 (Backward compatible with 40G QSFP+ transceiver)
- 10GBASE-SR/LR SFP+ port x 2
- Hot-pluggable fan modules x 2
- Hardware stacking up to 2 units

### DCS-7342-48Y8C

- 25G SFP28 port x 48(Backward compatible with 10GBASE-X SFP+)
- 100G QSFP28 port x 8 (Backward compatible with 40G QSFP+ transceiver)
- Hot-pluggable fan modules x 2
- Dual 100~240V AC modular power
- Hardware stacking up to 2 units

- Gigabit wire-speed Layer 3 IPv4 and IPv6 routing
- Multi-Chassis Link Aggregation (MLAG)
- VxLAN/EVPN support, extends IPv6 application capabilities over IPv4 infrastructure.
- IP routing protocol: static routing, OSPFv2/v3, BGP4/4+, RIPng, IS-IS
- IP multicast routing: IGMP, PIM-DM
- IEEE 802.1D/1W/1s Spanning Tree Protocol
- IEEE 802.1x, RADIUS, TACACS+, SSHv2.0, SNMPv3
- L2, L3 and L4 Access Control List and QoS
- Security and Event Management
- 100~240V AC Dual modular power supplies

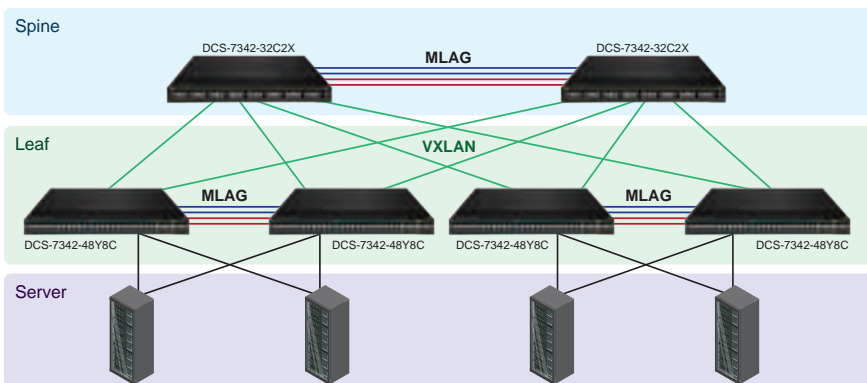

# Layer 3 Managed Chassis Switches

## CS-6306R



PLANET CS-6306R Core-Layer Routing Switch is specially designed for large network applications such as enterprises, campuses, communities, ISPs and data center networks where flexible configuration, large capacity, high density, high reliability and advanced traffic management are required.

The CS-6306R is a high-density chassis-based routing switch built with 6 module slots and redundant power supply. It provides great porting flexibility for network deployment by offering various and combinable management modules and standard interfaces. With 10-Gigabit and 40-Gigabit Ethernet technology applied, the CS-6306R provides broad bandwidth and powerful processing capacity. The Chassis Switch supports wire-speed L2/ L3 forwarding and high routing performance for IPv4 and IPv6 protocols.

### CS-6306R

- 192-port 10/100/1000BASE-T copper
  - 192 1000BASE-SX/LX SFP fiber slots
  - 64 10G XFP fiber slots
  - 16 40G QSFP+ fiber slots
  - 19-inch, 9U rack-mount
- 
- Gigabit wire-speed Layer 3 IPv4 and IPv6 routing
  - Four slots for optional Gigabit/10 Gigabit modules
  - IP routing protocols: static routing, RIPv1/v2, OSPFv2, BGP4 & VRRP
  - IP multicast routing: IGMP, PIM-DM/SM
  - IEEE 802.1Q, Private VLAN and GVRP for VLAN management
  - IEEE 802.1D/1w/1s Spanning Tree Protocol
  - IEEE 802.1x, RADIUS, TACACS+, SSH and SSL
  - L2, L3 and L4 Access Control List and QoS
  - 100~240V AC redundant power system

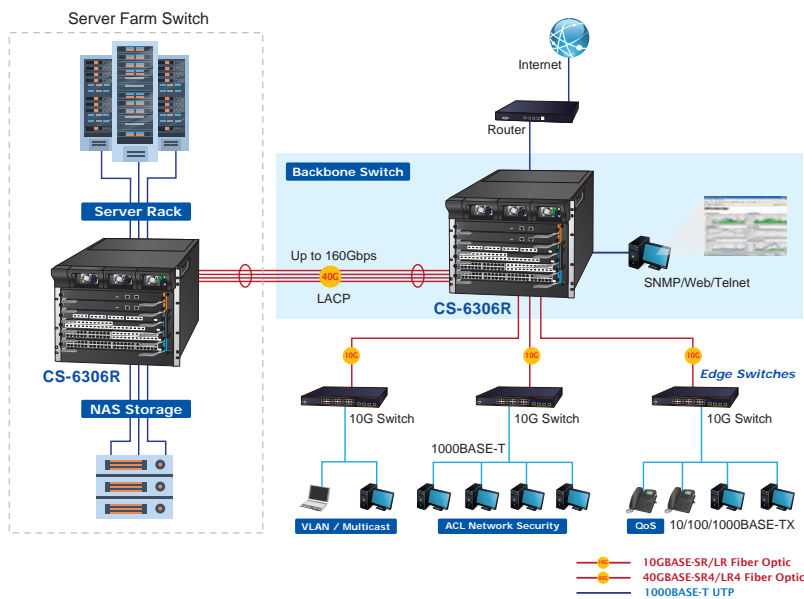

Module	CS6-S48T	CS6-S48S	CS6-S24S8X	CS6-S24T8X	CS6-S24T24S	CS6-S16X	CS6-S4Q
--------	----------	----------	------------	------------	-------------	----------	---------



Product	CS6-S48T	CS6-S48S	CS6-S24S8X	CS6-S24T8X	CS6-S24T24S	CS6-S16X	CS6-S4Q
10/100/1000T	48	-	-	24	24	-	-
1000X SFP	-	48	24	-	24	-	-
10G SFP+	-	-	8	8	-	16	-
40G QSFP+	-	-	-	-	-	-	4

# 10G/40G/100G Fiber Managed Switches

XGS-6350 Series/XGS-5240-24X2QR



## Powerful Layer 3 Routing with Multiple 10Gbps~100Gbps Fiber Solution

PLANET XGS-6350 series, consisting of Layer 3 10Gbps~100Gbps Managed Switches, provides hardware-based Layer 3 routing capability with IPv4/IPv6 static routing, RIP (Routing Information Protocol) and OSPF (Open Shortest Path First) routing features. With ultra-high switching fabric, the XGS-6350 series can handle extremely large amounts of data in a secure topology linking to backbone or high capacity servers for enterprises, data centers, campuses and so on where VoIP, video streaming, and multicast applications are utilized.

## XGS-6311 Series/XGS-6320 Series



## 10GBASE-T and 10GBASE-X SFP Dual Media Interfaces for Diversified Bandwidth Applications

PLANET XGS-6311/XGS-6320 series is a fully-managed all-port 10Gbps Ethernet switch designed for the demand of high-bandwidth required network equipment, such as Wi-Fi 7/6E wireless AP, NAS, workstation and those with 10Gbps fiber or copper interfaces. It has the capability to reach a high speed of 10Gbps over copper or fiber-optic cabling which helps to accelerate the performance of large data transmission. The built-in 10GBASE-T copper interfaces support 5-speed (10G/5G/2.5G/1G/100) auto-negotiation, and 10Gbps data transmission with the existing Cat6A/Cat7 UTP cabling.

### XGS-6350-48X2Q4C

- 10G/1G SFP+ ports x 48
- 40G QSFP+ ports x 2
- 100G QSFP28 ports x 4
- Optional Hot-swappable 100~240V AC/36-72V DC redundant power
- Detachable fan modules

### XGS-6350-24X4C

- 40G/100GbE QSFP28 port x 4
- 1G/10G SFP+ port x 24

### XGS-6350-24X2C

- 40G/100GbE QSFP28 ports x 2
- 1G/10G SFP+ ports x 24

### XGS-6350-12X8TR

- 1G/10G SFP+ port x 12
- 10/100/1000BASE-T port x 8
- Dual 100~240V AC redundant power

### XGS-5240-24X2QR

- 1G/10G SFP+ port x 24
- 40G QSFP+ port x 2
- 100~240V AC and 36~72V DC redundant power system

### XGS-6311-12X

- 10G/1G SFP+ port x12
- 13-inch desktop size

### XGS-6311-8T4XR

- 10G/2.5G/1G SFP+ ports x 8
- 10G/5G/2.5G/1G/100BASE-T RJ45 ports x 4
- Dual 100~240V AC redundant power
- ITU G.8032 ERPS Ring

### XGS-6320-8X8TR

- 10G/2.5G/1G SFP+ port x 8
- 10G/5G/2.5G/1G/100BASE-T RJ45 port x 8
- 100~240V AC/36-60V DC redundant power
- ITU G.8032 ERPS Ring

### XGS-6320-12X4TR

- 10G/2.5G/1G SFP+ port x 12
- 10G/5G/2.5G/1G/100BASE-T RJ45 port x 4
- 100~240V AC/36-60V DC redundant power
- ITU G.8032 ERPS Ring

### XGS-6320-8UP4X

- 10G/2.5G/1G SFP+ port x 4
- 10G BASE-T 802.3bt PoE++ RJ45 port x 8
- 420-watt PoE budget

# Layer 3 Enterprise Stackable Managed Switches

SGS-6341 Series/SGS-6310 Series/XGS3 Series



## Cost-effective Layer 3 Routing Solution for Enterprise Intranet Networking

Designed for enterprises and small to medium-sized businesses where an intranet routing network is built, PLANET SGS-6341/SGS-6310 series, a Layer 3 Stackable Gigabit Managed Switch, provides hardware-based Layer 3 routing capability with IPv4 and IPv6 static routing, RIP (Routing Information Protocol) and OSPF (Open Shortest Path First) routing features which allow to cross over different VLANs and different IP addresses, and performs effective data traffic control for security, VoIP and video streaming applications.

## Efficient IP Stacking Management

The SGS-6341 series supports IP stacking function that helps network managers to easily configure up to 24 switches in the same series via one single IP address instead of connecting and setting each unit one by one. It enables centralized management regardless of the series of switches being distributed in various locations. New switches can be flexibly added to the IP stacking group when network expands.

- IP Routing protocols: Static Routing, RIPv1/v2 and OSPFv2
- IPv4 and IPv6 Web Interface; SNMP v1, v2c and v3; SSH and SSL management
- IEEE 802.1Q VLAN, Private VLAN and GVRP
- IEEE 802.1w/1s/1D Spanning Tree Protocol
- Layer 2,3 and 4 Access Control List and QoS
- IGMP Snooping v1, v2 and v3; and MLD Snooping v1 and v2
- IP stack: up to 24 units and single IP address stack management



### XGS3-2424Z

- 100/1000BASE-X SFP port x 24
- 10/100/1000BASE-T port x 8 shared with Port-1 to Port-8
- 10GBASE-X SFP+ port x 4
- 100~240V AC and 36~75V DC redundant power

### SGS-6341-48T4X

- 10/100/1000BASE-T port x 48
- 10GBASE-X SFP+ port x 4
- USB interface for configuration file backup or upload

### SGS-6341-16S8C4XR

- 100/1000BASE-X SFP port x 24
- 10/100/1000BASE-T port x 8 shared with Port-1 to Port-8
- 10GBASE-X SFP+ port x 4
- 100~240V AC and 36~75V DC redundant power system

### SGS-6341-24T4X

- 10/100/1000BASE-T port x 24
- 10GBASE-X SFP+ port x 4
- USB interface for configuration file backup or upload

### SGS-6341-24P4X

- 10/100/1000BASE-T with 802.3at PoE+ port x 24
- 10GBASE-X SFP+ port x 4
- 370-watt PoE budget

### SGS-6310-48T6X

- 10/100/1000BASE-T port x 48
- 10GBASE-X SFP+ port x 6
- Hardware stacking up to 8 units

### SGS-6310-24T4X

- 10/100/1000BASE-T port x 24
- 10GBASE-X SFP+ port x 4
- Hardware stacking up to 8 units

### SGS-6310-16S8C4XR

- 100/1000BASE-X SFP port x 24
- 10/100/1000BASE-T port x 8, shared with Port-1 to Port-8
- Dual 100~240V AC redundant power system
- Hardware stacking up to 8 units

### SGS-6310-48P6XR

- 10/100/1000BASE-T with 802.3at PoE+ port x 48
- 10GBASE-X SFP+ port x 6
- 370~740-watt PoE budget
- 100~240V AC and 55V DC dual power input for maximum PoE budget
- Hardware stacking up to 8 units

### SGS-6310-24P4X

- 10/100/1000BASE-T with 802.3at PoE+ port x 24
- 10GBASE-X SFP+ port x 4
- 370-watt PoE budget
- Hardware stacking up to 8 units

# 10G Layer 3 Managed Gigabit Switches

## GS-6311 Series



PLANET GS-6311 series is a Layer 3 Managed Gigabit Switch that provides high-density performance, Layer 3 static routing, RIP (Routing Information Protocol) and OSPF (Open Shortest Path First). With 10Gbps interfaces, the GS-6311 series can handle extremely large amounts of data in a secure topology linking to an enterprise backbone or high-capacity servers. The powerful network security features make the GS-6311 series perform effective data traffic control for ISP and enterprise VoIP, video streaming, and multicast applications.

- IPv4 and IPv6 Layer 3 static routing
- IEEE 802.1Q VLAN, Private VLAN and Q-in-Q
- IGMP Snooping v1, v2 and v3; and MLD Snooping v1 and v2
- IEEE 802.1s MSTP and loop protection
- IPv6 Web interface; SNMP v1, v2c and v3; and SSH and SSL management

### GS-6311-24T4X

- 10/100/1000BASE-T port x 24
- 10GBASE-X SFP+ Slots x 4

### GS-6311-24HP4X

- 10/100/1000BASE-T port x 24
- 10GBASE-X SFP+ Slots x 4
- 802.3bt PoE++ port x8
- 802.3at PoE+ port x16
- 480-watt PoE budget

### GS-6311-16S8C4XR

- 10/100/1000BASE-T port x 8, shared with Port 1 to Port 8
- 100/1000BASE-X SFP Slots x24
- 10GBASE-X SFP+ Slots x 4
- 100~240V AC, 50/60Hz and 36~72V DC redundant power

### GS-6311-48T6X

- 10/100/1000BASE-T port x 48
- 10GBASE-X SFP+ Slots x 6

### GS-6311-48P6X

- 10/100/1000BASE-T 802.3at PoE+ port x48
- 10GBASE-X SFP+ Slot x 6
- 600-watt PoE budget

### GS-6311-24P4XV

- 10/100/1000BASE-T with 802.3at PoE+ port x 24
- 10G/10GBASE-X SFP+ slot x 4
- 370-watt PoE budget
- 2-inch Smart Color LCD for easy management and monitoring

# Layer 3/2+ IPv6 Managed Metro Switches

## MGSW Series



To fulfill the growing demand for IP network deployment from LAN to MAN (Metropolitan Area Network), PLANET MGSW Gigabit Metro Ethernet Switch Series is specially designed to deliver profitable wide-ranging Ethernet network based on the optical fiber technology. Furthermore, it adopts "Front Access" design for easy wiring and maintenance of the MGSW Series in the cabinet.

- Redundant power system: dual -36V~-60V DC and 100V~240V AC
- -10 to 60 degrees C operating temperature
- IEEE 802.1Q VLAN, Protocol VLAN, GVRP and MVR
- IEEE 802.1D/1w/1s Spanning Tree Protocol for Ethernet redundancy
- Policy-based QoS, bandwidth control and storm control
- Layer 2, 3 and 4 Access Control List and port security
- Web; SNMP v1, v2c, v3; and Telnet remote IP management
- IPv6 and IPv4 dual stack management
- Digital input and digital output
- Front access design
- 19-inch,1U rack-mountable installation

### MGS-6320-2T6S2X

- 100/1000BASE-T port x 2
- 100/1000BASE-X SFP port x 2
- 100/1000/2500BASE-X SFP port x 4
- 1000/2500/10GBASE-X SFP+ port x 2
- Supports ITU-G.8032 ERPS Ring
- Layer 3 OSPFv2 dynamic routing

### MGSD-10080F

- 100/1000BASE-X SFP port x 6
- 100/1000/2500BASE-X SFP port x 2
- 10/100/1000BASE-T port x 2
- Supports ITU-G.8032 ERPS Ring

### MGSW-24160F

- 100/1000BASE-X SFP port x 12
- 10/100/1000BASE-T port x 8
- 10G BASE-X SFP+ Slots x 4

### MGSW-28240F

- 10/100/1000BASE-T ports x 4
- 100/1000BASE-X SFP port x 14
- 100/1000/2500BASE-X SFP port x 10
- 1000/2500/10GBASE-X SFP+ port x 4
- Supports ITU-G.8032 ERPS Ring
- Layer 3 OSPFv2 dynamic routing





# 10G Layer 3 IPv6 Managed Gigabit Switches

## GS-5220 Series/GS-6320 Series



PLANET GS-5220/GS-6320 10G series is the Layer 3 IPv6 and IPv4 Gigabit Ethernet switch with 10Gbps uplink to greatly support SMB and enterprise networks to achieve 10Gbps high performance in a cost-effective way. The GS-5220/GS-6320 Series can work with PLANET ENW-9800 series or the third-brand 10Gbps server adapter to help SMBs build 10Gbps Ethernet network providing 10Gbps NAS (Network Attached Storage) or heavy transmission of video streaming service at an affordable price.

- IP Routing Protocols: Static Routing and OSPFv2
- 4 SFP+ slots support dual-speed, 10GBASE-SR/LR & 1GBASE-SX/LX/BX
- IPv6 Web interface; SNMP v1, v2c and v3; SSH and SSL management
- IEEE 802.1Q VLAN, Private VLAN, Q-in-Q, Protocol-based VLAN and MAC-based VLAN
- IEEE 802.1D/1w/1s Spanning Tree Protocol for Ethernet redundancy
- Layer 2, 3 and 4 Access Control List
- IGMP Snooping v1, v2 and v3; and MLD Snooping v1 and v2
- 19-inch, 1U rack-mount



CRPS Power supplies  
GS-6322-24P4X

### GS-6320-46S2C4XR

- 100/1000BASE-X SFP port x 48
- 10G SFP+ port x 4
- 10/100/1000BASE-T port x 2
- 1U height, 19-inch rack-mountable

## PoE Models

### GS-6322-24P4X

- 10/100/1000BASE-T with 802.3bt PoE port x 24
- 100/1G/2.5G/5G/10GBASE-T port x 2
- 1G/2.5G/10G SFP+ port x 2
- Up to 2280 watts PoE budget
- Up to 95 watts PoE output
- Supports dual 100~240V AC redundant power

### GS-5220-8UP2T2X

- 10/100/1000BASE-T with 802.3at/bt PoE+ port x 8
- 10/100/1000BASE-T port x 2
- 10G SFP+ port x 2
- 240-watt PoE budget
- Up to 95 watts per PoE port

### GS-6320-8P2X

- 10/100/1000BASE-T with 802.3at PoE+ port x 8
- 1G/2.5G/10G SFP+ port x 2
- 120-watt PoE budget
- Up to 36 watts per PoE port

# Multigigabit L3 IPv6 Managed PoE Switches

## MGS-6311/MGS-6320 Series



Multigigabit  
2.5G

The MGS-6311/MGS-6320 series is PLANET's first Multigigabit Layer 3 Managed Switch designed in compact size. Offering 8-port PoE 2.5GBASE-T and 2-port dual speed 10G SFP+, it breaks the bandwidth limitation of connecting the wireless network with the wired network. Featuring Layer 3 routing and PLANET Intelligent PoE functions, it provides a highly-secure, environment-friendly network management and accelerates the deployment of wireless network infrastructure for smart cities.

- 8 100/1000/2.5GBASE-T ports, 2 dual speed SFP+ slots
- 8 ports with 30~36W PoE output
- Intelligent PoE functions including PD alive check, PoE schedule, scheduled power recycling and over-temperature protection
- 13-inch compact size

### MGS-6320-8T2X

- 2.5G/1G/100BASE-T port x 4
- 1G/100/10BASE-T port x 4
- 10G/2.5G/1GBASE-X SFP+ slot x 2

### MGS-6320-8HP2X

- 2.5G/1G/100BASE-T with 802.3bt PoE++ port x 4
- 1G/100/10BASE-T with 802.3at PoE+ port x 4
- 10G/2.5G/1GBASE-X SFP+ slot x 2
- 240-watt PoE budget
- Up to 95 watts per PoE++ port

### MGS-6311-10T2X

- 2.5G/1G/100BASE-T port x 8
- 10G/5G/2.5G/1GBASE-T port x 2
- 10G/1GBASE-X SFP+ port x 2

### MGS-6311-8P2X

- 2.5G/1G/100BASE-T with 802.3at PoE+ port x 8
- 10G/1GBASE-X SFP+ port x 2
- 150-watt PoE budget
- 13-inch desktop size, 19-inch rack-mountable

# Touch LCD 10G Layer 3 IPv6 Managed Gigabit Switches



## Intuitive LCD for Efficient Management

PLANET GS-6320-24UP2T2XV provides an intuitive touch panel on their front panels that facilitate the Ethernet management and PoE PD management. They greatly promote management efficiency in large-scale network and feature the following special management and status functions:

- IP address, VLAN and QoS configuration
- PoE management and status
- Port management and status/SFP information
- Troubleshooting: cable diagnostic and remote IP ping
- Maintenance: reboot, factory default and save configuration

The GS-6320-24UP2T2XV LCD PoE switch models featuring PLANET intelligent PoE management to improve the availability of critical business applications have an awesome feature -- ONVIF Support -- which is specifically designed for co-operating with Video IP Surveillances. From the GUI, you just need one click to search and show all of the ONVIF devices via network application, thus enabling to pinpoint the location of the particular surveillance device for easier inspection and planning.

## GS-6320-24UP2T2XV

- 10/100/1000BASE-T with 802.3bt PoE port x 24
- 1G/10G SFP+ port x 2
- 10GBASE-T port x 2
- 600-watt PoE budget
- Up to 95 watts PoE output
- Supports 100~240V AC/48~60V DC redundant power

# Layer 2+ IPv6 Managed Gigabit Switches

## WGSW Series/GS-5220 Series



PLANET WGSW and GS-5220 series support both IPv4 and IPv6 management functions, and IPv4 and IPv6 Layer 3 static routing. It offers IPv4 and IPv6 VLAN routing feature which allows to crossover different VLANs and different IP addresses for the purpose of having a highly-secure, flexible management and simpler networking applications.

The GS-5220 Fiber Switch series as the fiber backbone switch providing 24 100/1000BASE-X dual-speed SFP slots can flexibly work with suitable SFP transceivers to have a long connection of up to 120km via optic fiber cabling.

With easy and friendly management interfaces and plenty of management functions included, PLANET WGSW and GS-5220 series is the best choice for ISPs to build the IPv6 FTTx edge service and for SMBs to connect with IPv6 network.

- IPv4 and IPv6 Layer 3 static routing
- IPv6 Web interface; SNMP v1, v2c and v3; SSH and SSL management
- Static and IEEE 802.3ad Link Aggregation
- DHCP snooping/ARP Inspection and IP Source Guard
- IEEE 802.1Q VLAN, Private VLAN, Q-in-Q, Protocol-based VLAN and MAC-based VLAN
- IEEE 802.1D/1w/1s Spanning Tree Protocol
- QoS control list and bandwidth control
- 802.1X, RADIUS and TACACS+ authentication
- Layer 2, 3 and 4 Access Control List
- IGMP snooping v1, v2 and v3; and MLD snooping v1 and v2
- PoE models support PD alive check, PoE schedule, scheduled power recycling and over temperature protection

## GS-5220-16S8CR

- 10/100/1000BASE-T port x 8
- 100/1000BASE-X SFP port x 24
- 10G BASE-X SFP+ slots x 4
- Each SFP slot supports DDM
- 100~240V AC/36~72V DC redundant power

## PoE Models

## GS-5220-8P2T2S

- 10/100/1000BASE-T with 802.3at PoE+ port x 8
- 10/100/1000BASE-T port x 2
- 100/1000BASE-X SFP port x 2
- 240-watt PoE budget
- 13-inch desktop size, 1U rack-mountable
- Smart fan design for silent operation

## WGSW-24040HP4

- 10/100/1000BASE-T with 802.3at PoE+ port x 24
- 100/1000BASE-X SFP port x 4
- 440-watt PoE budget

# Layer 2/4 IPv4/IPv6 Managed Gigabit Switches

## GS-4210 Series



PLANET GS-4210 switch series is perfectly designed for SMB and SOHO network infrastructures. Besides the hot IPv6 and IPv4 management, and abundant L2/L4 switching functions, the series of switch adopts the fanless and green technology to provide a quiet, energy saving, high-speed and reliable office network environment. It benefits the SMB and SOHO users as it is in the Gigabit network environment with a low cost of Fast Ethernet switches. The series of switch is quite suitable for the next generation network deployment and offers the lowest total cost of ownership. It is the best investment for business expansion or upgrading its network infrastructure.

- IEEE 802.1Q VLAN, Q-in-Q, Private VLAN and GVRP
- IEEE 802.1w RSTP, IEEE 802.1s MSTP and loop protection
- IGMP snooping v2 and v3, and MLD snooping
- QoS, Voice VLAN and bandwidth control
- Layer 2, 3 and 4 Access Control List
- IEEE 802.1X and RADIUS authentication
- IPv4 and IPv6 Web interface; Telnet; SNMP v1, v2c and v3; and SSH and SSL management
- PoE models support PD alive check, PoE schedule, scheduled power recycling and over temperature protection

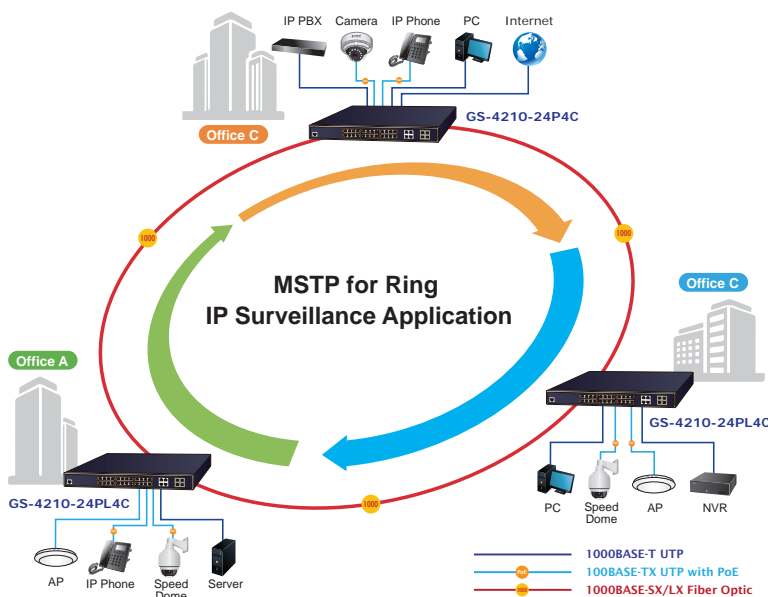

### GS-4210-16T2S

- 10/100/1000BASE-T port x 16
- 100/1000BASE-X SFP port x 2
- Fanless

### GS-4210-24T2S

- 10/100/1000BASE-T port x 24
- 100/1000BASE-X SFP port x 2
- Fanless

### GS-4210-24T4S

- 10/100/1000BASE-T port x 24
- 100/1000BASE-X SFP Port x 4
- 100~240V AC, 50/60Hz power supply
- Fanless

### GS-4210-24T4SR

- 10/100/1000BASE-T port x 24
- 100/1000BASE-X SFP Slots x 4
- 100~240V AC, 50/60Hz and 36~72V DC redundant power
- Fanless

### GS-4210-48T4S

- 10/100/1000BASE-T port x 48
- 100/1000BASE-X SFP port x 4
- Fanless

## PoE Models

### GS-4210-16P2S

- 10/100/1000BASE-T with 802.3at PoE+ port x 16
- 100/1000BASE-X SFP port x 2
- 220-watt PoE budget
- Up to 36 watts per PoE port

### GS-4210-16P4C

- 10/100/1000BASE-T with 802.3at PoE+ port x 16
- 10/100/1000BASE-T port x 4
- 100/1000BASE-X SFP port x 4
- 240-watt PoE budget
- Up to 30 watts per PoE port

### GS-4210-24P2S

- 10/100/1000BASE-T with 802.3at PoE+ port x 24
- 100/1000BASE-X SFP slots x 2
- 300-watt PoE budget
- Up to 30 watts per PoE port

### GS-4210-24P4C/GS-4210-24PL4C

- 10/100/1000BASE-T with 802.3at PoE+ port x 24
- 10/100/1000BASE-T port x 4
- 100/1000BASE-X SFP port x 4
- 280/430-watt PoE budget
- Up to 30 watts per PoE port

### GS-4210-48P4S

- 10/100/1000BASE-T with 802.3at PoE+ port x 48
- 100/1000BASE-X SFP port x 4
- 600-watt PoE budget
- Up to 36 watts per PoE port

### GS-4210-16UP8T4X/GS-4210-24UP4X

- 10/100/1000BASE-T port x 8 (GS-4210-16UP8T4X)
- 10/100/1000BASE-T with 802.3bt PoE++ port x 16/24
- 10GBASE-X SFP+ slot x 4
- Up to 95 watts of PoE power on 4-pair UTP
- 420/720-watt PoE budget

# Layer 2/4 IPv6 Desktop-size Managed Gigabit Switches



PLANET GSD and GS-4210 desktop Gigabit Switch series, the smallest Managed Gigabit Switch in the networking industry, integrates with 8-port 10/100/1000BASE-T copper and 2 extra 100/1000BASE-X SFP fiber optic interfaces in a handheld size metal case, with powerful L2 and L4 network switching engine and advanced IPv6 and IPv4 management functions inside. Without space limitation, it is easy to install the desktop-size switches, ideal for communication closet or desktop. It is ready to bring superior usability and improves user experiences.

- IEEE 802.1Q VLAN, Q-in-Q, Private VLAN and GVRP
- IEEE 802.1w RSTP, IEEE 802.1s MSTP and loop protection
- IGMP snooping v2 and v3, and MLD snooping
- QoS, Voice VLAN and bandwidth control
- Layer 2, 3 and 4 Access Control List
- IEEE 802.1X and RADIUS authentication
- IPv4 and IPv6 Web interface; Telnet; SNMP v1, v2c and v3; and SSH and SSL management

## Web Smart Ethernet Switch

### GS-2210 Series



#### Efficient Network Management Through NMS and App

The GS-2210 Web Smart Switch series, known for such features as QoS, Link aggregation, VLANs, IGMP, and so on, provides an eye-catching feature called NMS developed by PLANET to easily and remotely manage and monitor network devices in the local environment from mobile app. This feature not only improves operational convenience, but also ensures users to have real-time control over their network infrastructure. It provides users with an unparalleled experience.

- PLANET NMS and NMSViewerPro for deployment management
- 8 to 24 IEEE 802.3at PoE ports with a total PoE budget of up to 260 watts
- Supports PoE schedule, PD alive check and ONVIF
- Supports static trunk, QoS, port isolation and cable diagnostics
- IPv4 IGMP snooping v1, v2; DHCP snooping and IEEE 802.1Q VLAN

#### GS-4210-8T2S

- 10/100/1000BASE-T port x 8
- 100/1000BASE-X SFP port x 2
- 12-inch desktop size, 19-inch rack-mountable
- Internal power supply

#### GSD-1002M

- 10/100/1000BASE-T port x 8
- 100/1000BASE-X SFP port x 2
- 1 port supports 802.3af/at PoE DC 48~56V in-line power
- Compact size, wall-mount

### PoE Models

#### GS-4210-8P2S

- 10/100/1000BASE-T with 802.3at PoE+ port x 8
- 100/1000BASE-X SFP port x 2
- 120-watt PoE budget
- 12-inch desktop size, 1U rack-mountable

#### GS-4210-8P2C

- 10/100/1000BASE-T with 802.3at PoE+ ports x 8
- 10/100/1000BASE-T ports x 2
- 100/1000BASE-X SFP ports x 2
- 120-watt PoE budget
- 12-inch desktop size, 1U rack-mountable

#### GS-4210-8UP2S

- 10/100/1000BASE-T with 802.3bt PoE++ port x 8
- 100/1000BASE-X SFP port x 2
- 180-watt PoE budget

#### GS-2210-8T2S/GS-2210-16T2S/ GS-2210-24T2S

- 10/100/1000BASE-T port x 8/16/24
- 100/1000BASE-X SFP port x 2

### PoE Models

#### GS-2210-8P2S/GS-2210-16P2S/ GS-2210-24P2S

- 10/100/1000BASE-T with 802.3at PoE+ port x 8/16/24
- 100/1000BASE-X SFP port x 2
- 120/240/260-watt PoE budget

## Layer 2 Unmanaged Gigabit Switches

- Auto MDI/MDIX on each port
- CSMA/CD protocol
- Store-and-Forward
- MAC address learning and aging
- Flow control to eliminate packet loss
- Auto-negotiation

### GSW-1601

- 10/100/1000BASE-T port x 16
- 9K jumbo frame
- 8K MAC address table
- DIP switch for standard/VLAN/Flow control/Extend mode selection
- Fanless
- 19-inch, 1U rack-mountable



### GSW-2401

- 10/100/1000BASE-T port x 24
- 9K jumbo frame
- 8K MAC address table
- DIP switch for standard/VLAN/Flow control/Extend mode selection
- Fanless
- 19-inch, 1U rack-mountable



### GSD-503/GSD-803

- 10/100/1000BASE-T port x 5 (GSD-503)
- 10/100/1000BASE-T port x 8 (GSD-803)
- 9K jumbo frame
- Green networking for energy saving
- Made of metal



### GSD-504/GSD-804

- 10/100/1000BASE-T port x 5 (GSD-504)
- 10/100/1000BASE-T port x 8 (GSD-804)
- 9K jumbo frame
- Green networking for energy saving
- Made from plastic



### GSD-805

- 10/100/1000BASE-T port x 8
- 9K jumbo frame
- Internal power supply
- Desktop/wall-mount



### WGS-810

- 10/100/1000BASE-T port x 8
- 9K jumbo frame
- Green networking for energy saving
- Made of metal
- Flat-type design
- Wall-mount, magnetic wall mounting or DIN-rail mounting



## Layer 2 Unmanaged Fast Ethernet Switches

### FSD-503/FSD-803

- 10/100BASE-TX port x 5 (FSD-503)
- 10/100BASE-TX port x 8 (FSD-803)
- One power button
- Made of metal



### SW-504/SW-804

- 10/100BASE-TX port x 5 (SW-504)
- 10/100BASE-TX port x 8 (SW-804)
- 802.1Q VLAN transparency
- Made from plastic



### FNSW-1601

- 10/100BASE-TX port x 16
- 8K MAC address table
- Green networking for energy saving
- 802.1Q VLAN transparency
- 19-inch, 1U rack-mountable
- DIP switch for standard/VLAN/Flow control/Extend mode selection



### FNSW-2401

- 10/100BASE-TX port x 24
- 8K MAC address table
- Green networking for energy saving
- 802.1Q VLAN transparency
- 19-inch, 1U rack-mountable
- DIP switch for standard/VLAN/Flow control/Extend mode selection



# Empowering **Industry 4.0** with Seamless Connectivity and Reliable Networking



**Intelligent PoE Management**



**L3 OSPF Routing**



**10G Uplink**



**Cyber Security**



**RING**

## Comprehensive Industrial Networking Products



**Fiber Switch**



**PoE**



**Renewable Energy**



**Flat-type**



**Media Conversion**



**Router**

# Industrial Ethernet

## Unique Flat-type Design for Easy Management

To facilitate the network deployment in any space-limited locations like wall enclosure or electric box found in buildings or outdoors, PLANET has the industrial Ethernet switches and wireless AP designed in a compact flat type. The products can be installed by fixed wall mounting, magnetic wall mounting or DIN rail, thereby making its usability more flexible.

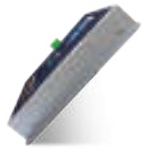

Flat Design



Magnetic Installation



Front Access



## Industry-leading Integration of PoE Technology and Renewable Energy

PLANET Industrial Renewable Energy PoE Switch utilizes the inexhaustible and natural source of energy, such as solar, wind and hydroelectric power to conserve energy, and incorporates 802.3at high power PoE technology to enable network deployment anywhere without any obstacles of geographical barrier. It greatly accelerates the installations of wireless LAN or IP surveillance systems in remote areas.

## EN50155 Ready for Intelligent Transportation Systems

Bringing uninterrupted operation and reliable network transmission for rolling stock applications, PLANET EN50155 compliant Industrial Ethernet Switches provide waterproof M12/RJ45 interfaces and guarantee stable Ethernet operation performance under high vibration and shock environment. The switches also feature wide-ranging operating temperature, redundant ring recovery, and intelligent PoE PD and power management functions, ensuring the highest level of reliability for mission-critical applications in any difficult environment.



# Layer 3 and Layer 2 Industrial Managed Gigabit Switches

PLANET Industrial Ethernet Switches are industrially hardened to be specially designed to operate reliably in electrically harsh and climatically demanding environment. PLANET Layer 3 and Layer 2 Industrial Managed Switches, with model names starting with IGS or IGSW, include Managed Switches, Unmanaged Switches and PoE Switches. They all support full Gigabit port. The capital 'T' in the model name means that the product can support and operate under wide-ranging temperature from -40 to 75 degrees C.

## Redundant Ring and Fast Recovery for Surveillance System

The IGS and IGSW series features strong, rapid self-recovery capability to prevent interruptions and external intrusions. It incorporates advanced ITU-T G.8032 ERPS (Ethernet Ring Protection Switching) technology, Spanning Tree Protocol (802.1s MSTP), and redundant power input system into customer's industrial automation network to enhance system reliability and uptime in harsh factory environments. In certain simple ring network, the recovery time of data link can be as fast as 20ms.

### IMS-6325-5

- 10" Modular-based Ethernet Switch
- Fixed 4-port 10/100/1000BASE-T RJ45
- Fixed 4-port 1G/2.5G/10GBASE-X SFP+
- 5 flexible modular slots
- 4-port 10/100/1000BASE-T RJ45 line card module (IMS-4T)
- 4-port 100/1000BASE-X SFP line card module (IMS-4S)
- IEEE 1588 PTP transparent clock supported
- ITU G.8032 ERPS ring supported
- Layer 3 Dynamic Routing, RIPv1/v2 and OSPFv2/v3
- Built-in 2 DI and 2 DO



### IGS-6325-20T4C4X

- 24-port 10/100/1000BASE-T
- 4-port 100/1000BASE-X SFP
- 4-port 1G/2.5G/10GBASE-X SFP+
- IPv6/IPv4 Web, Telnet and SNMP management
- 802.1Q VLAN, MSTP and IGMP snooping
- ERPS ring supported
- L3 static route and OSPFv2 supported
- DI and DO supported
- 100~240V AC and 24~60V DC redundant power system



### IGS-6325-20S4C4X

- 4-port 10/100/1000BASE-T
- 14-port 100/1000BASE-X SFP
- 10-port 100/1G/2.5GBASE-X SFP
- 4-port 1G/2.5G/10GBASE-X SFP+
- IPv6/IPv4 Web, Telnet and SNMP management
- 802.1Q VLAN, MSTP and IGMP snooping
- ERPS ring supported
- Static route and OSPFv2 supported
- DI and DO supported
- 100~240V AC and 24~60V DC redundant power system
- EN 61000-6-2, EN 61000-6-4



### IGS-5225-16T4S/IGSW-24040T

- 16/24-port 10/100/1000BASE-T
- 4-port 100/1000BASE-X SFP
- IPv6/IPv4 Web, Telnet and SNMP management
- 802.1Q VLAN, MSTP and IGMP snooping
- DI and DO supported
- ERPS ring supported
- 100~240V AC and 36~60V DC redundant power system



### IGS-R4215-24T4X

- 24-Port 10/100/1000 BASE-T RJ45
- 4-Port 100/1G/2.5G/10GBASE-X SFP+
- USB-to-RS232 console management interface
- DI and DO supported
- ITU G.8032 ERPS ring
- Layer 3 Static route supported
- 100~240V AC and 24~60V DC redundant power system



### TSN-5225-6T2C/TSN-5225-4T2S/TSN-5225-4T

- Up to 8-port 10/100/1000BASE-T RJ45
- Up to 2-port 100/1000BASE-X SFP
- TSN(Time Sensitive Networking) technology
- IEEE 1588 PTP Master/Slave/Boundary/Transparent Clock
- ITU G.8032 ERPS ring
- 2 DI and 2 DO supported



### TSN-6325-8T4S4X

- 8-port 10/100/1000BASE-T
- 4-port 100/1G/2.5GBASE-X SFP
- 4-port 1G/2.5G/10GBASE-X SFP+
- TSN (Time Sensitive Networking) technology
- IEEE 1588 PTP Master/Slave/Boundary/Transparent Clock supported
- ERPS ring supported
- Layer 3 RIPv1/v2 and OSPFv2/v3 dynamic routing
- DI and DO supported



### IGS-6325-5X1T

- 5-port 1G/2.5G/10GBASE-X SFP+
- 1-port 100/1G/2.5G/5G/10GBASE-T RJ45
- IEEE 1588 PTP Transparent Clock supported
- ERPS ring supported
- Layer 3 RIPv1/v2 and OSPFv2/v3 dynamic routing
- 802.1Q VLAN, MSTP and IGMP snooping
- DI and DO supported



### IGS-6325-4T2X

- 4-port 100/1G/2.5GBASE-T RJ45
- 2-port 1G/2.5G/10GBASE-X SFP+
- IEEE 1588 PTP transparent clock supported
- ITU G.8032 ERPS ring supported
- Layer 3 Dynamic Routing, RIPv1/v2 and OSPFv2/v3
- Built-in 2 DI and 2 DO





# Layer 3 and Layer 2 Industrial Managed Gigabit Switches

## IGS-6325-16T4S

- 16-port 10/100/1000BASE-T
- 4-port 100/1G/2.5GBASE-X SFP
- IEEE 1588 PTP Transparent Clock supported
- ERPS ring supported
- Layer 3 OSPFv2 dynamic routing
- 802.1Q VLAN, MSTP and IGMP snooping
- DI and DO supported



## IGS-6325-16T4X

- 16-port 10/100/1000BASE-T RJ45
- 4-port 1G/2.5G/10GBASE-X SFP+
- IEEE 1588 PTP transparent clock
- ITU G.8032 ERPS ring
- Layer 3 Dynamic Routing, RIPv1/v2 and OSPFv2/v3
- DI and DO supported
- IP30 aluminum case with fanless design
- Operating temperature ranges from -40 ~ 75°C
- Supports 2 DI/DO



## IGS-6325-8T8S4X/IGS-6325-8T8S IGS-6325-8T4X

- 8-port 10/100/1000BASE-T
- 8-port 100/1G/2.5GBASE-X SFP
- 4-port 10G BASE-X SFP+ (IGS-6325-8T8S4X)
- IPv6/IPv4 Web, Telnet and SNMP management
- 802.1Q VLAN, MSTP and IGMP snooping
- ERPS ring supported
- IEEE 1588 PTP TC supported
- Static route and OSPFv2 supported
- DI and DO supported

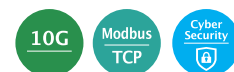

## IGS-5225-8T2S2X

- 8-port 10/100/1000BASE-T
- 2-port 100/1G/2.5GBASE-X SFP
- 2-port 10G BASE-X SFP+
- IPv6/IPv4 Web, Telnet and SNMP management
- 802.1Q VLAN, MSTP and IGMP snooping
- ERPS ring supported
- IEEE 1588 PTP TC supported
- Static route and OSPFv2 supported
- DI and DO supported



## IGS-20040MT/IGS-12040MT

- 16-/8-port 10/100/1000BASE-T
- 2-port 100/1000BASE-X SFP
- 2-port 100/1G/2.5GBASE-X SFP
- IPv6/IPv4 Web, Telnet and SNMP management
- 802.1Q VLAN, MSTP and IGMP snooping
- ERPS ring supported
- Static route supported
- DI and DO supported



## IGS-10080MFT/IGS-10020MT

- 6-port 100/1000BASE-X SFP (IGS-10080MFT)
- 2-port 10/100/1000BASE-T (IGS-10080MFT)
- 8-port 10/100/1000BASE-T (IGS-10020MT)
- 2-port 100/1G/2.5GBASE-X SFP
- IPv6/IPv4 Web, Telnet and SNMP management
- 802.1Q VLAN, MSTP and IGMP snooping
- ERPS ring supported
- Static route supported



## IGS-5225-4T2S

- 4-port 10/100/1000BASE-T
- 2-port 100/1000BASE-X SFP
- IPv6/IPv4 Web, Telnet and SNMP management
- 802.1Q VLAN, MSTP and IGMP snooping
- ERPS ring supported
- Static route supported



## IGS-4215-8T4X/IGS-4215-16T4X/ IGS-4215-24T4X

- 8/16/24-port 10/100/1000BASE-T RJ45
- 4-port 1G/2.5G/10GBASE-X SFP+
- USB-to-RS232 console management interface
- Supports G.8032 ERPS ring
- IP30 aluminum case with fanless design
- Operating temperature ranges from -40 ~ 75°C
- Support 2 DI/DO
- Layer3 Static route supported



## IGS-4215-16T2S/IGS-4215-16T2S-U

- 16-port 10/100/1000BASE-T
- 2-port 100/1000BASE-X SFP
- IPv6/IPv4 Web, Telnet and SNMP management
- 802.1Q VLAN, MSTP and IGMP snooping
- Loop protection
- QoS, bandwidth control, storm control, Layer3/4 access control list
- ERPS Ring and Loop protection supported



## IGS-4215-8T2S/IGS-4215-4T2S

- 8-port 10/100/1000BASE-T (IGS-4215-8T2S)
- 4-port 10/100/1000BASE-T (IGS-4215-4T2S)
- 2-port 100/1000BASE-X SFP
- IPv6/IPv4 Web, Telnet and SNMP management
- 802.1Q VLAN, MSTP and IGMP snooping
- ERPS Ring and Loop protection supported
- QoS, bandwidth control, storm control, Layer 3/4 access control list



## IGS-801M

- 8-port 10/100/1000BASE-T
- IPv6/IPv4 Web, Telnet and SNMP management
- 802.1Q VLAN, MSTP and IGMP snooping
- Loop protection
- QoS, bandwidth control, storm control, Layer3/4 access control list



# Layer 2 Industrial Gigabit Switches

PLANET advanced industrial hardened Ethernet Switch series comes with a slim type, IP30 metal case. The compact IP30 standard metal case allows either DIN rail or wall mounting for efficient use of cabinet space. The capital 'T' in the model name means that the product can support and operate under wide-ranging temperature from -40 to 75 degrees C.

The Layer 2 Industrial Switch series incorporates redundant power supply system into customer's industrial automation network to enhance system reliability and uptime in the factory harsh environments. It protects customer's industrial network connectivity with power redundant ability. They provide IP30 metal case and 100BASE-FX port or Gigabit TP/SFP combo interfaces for long-distance uplink.

## IGS-500T/IGS-510TF/IGS-501T

- 5-port 10/100/1000BASE-T
- -40 to 75 degrees C wide-ranging temperature
- IP30 metal case
- EEE (IGS-500T)
- Compact size (IGS-500T/IGS-510TF)
- 100/1000X SFP (IGS-510TF)



## IGS-800T/IGS-801T

- 8-port 10/100/1000BASE-T
- -40 to 75 degrees C wide-ranging temperature
- IP30 metal case
- EEE
- Compact size (IGS-800T)



## IGS-1600T/IGS-1820TF

- 16-port 10/100/1000BASE-T
- 2-port 1000BASE-X SFP (IGS-1820TF)
- -40~75 degrees C wide-ranging temperature
- IP40 metal case
- 12~48V DC, 24V AC redundant power



## IGS-620TF

- 4-port 10/100/1000BASE-T
- 2-port 100/1000BASE-X SFP (DIP control)
- -40 to 75 degrees C wide-ranging temperature
- IP30 metal case
- Dual SFP ports with auto link redundancy via DIP selection



## IGS-820TF

- 6-port 10/100/1000BASE-T
- 2-port 100/1000BASE-X SFP (DIP control)
- -40 to 75 degrees C wide-ranging temperature
- IP30 metal case
- Dual SFP ports with auto link redundancy via DIP selection
- Compact size



## IGS-1020TF

- 10/100/1000BASE-T x 8 ports
- 100/1000BASE-X SFP x 2 ports
- IEEE 802.3az EEE Protocol based power saving
- 12 ~ 48V DC, 24V AC redundant power
- -40 to 75 degree C operating temperature
- IP 30 metal case, DIN rail and wall mount design



## IGT-1205AT

- 1-port 10/100/1000BASE-T
- 2 x SFP interfaces compatible with 100FX/1000SX/LX (DIP control)
- -40 to 75 degrees C wide-ranging temperature
- IP30 metal case
- Dual SFP ports with auto link redundancy via DIP selection



## IGS-1000-8T4X

- 8-port 10/100/1000BASE-T RJ45
- 4-port 1G/2.5G/10GBASE-X SFP+
- 9~48V DC, 24V AC redundant power
- -40 ~ 75°C operating temperature
- IP30 aluminum case with fanless design



# Layer 2 Industrial Fast Ethernet Switches

## ISW-500T/ISW-800T

- 5/8-port 10/100BASE-TX
- -40 to 75 degrees C operating temperature
- IP30 metal case
- EEE



## ISW-501T/ISW-801T

- 5/8-port 10/100BASE-TX
- -40 to 75 degrees C wide operating temperature
- IP30 metal case
- EEE



## ISW-511T/ISW-511TS15

- 4-port 10/100BASE-TX
- 1-port 100BASE-FX
- Supports multi-mode fiber, 2km/15km distance
- -40 to 75 degrees C wide operating temperature
- IP30 metal case



## ISW-621T/ISW-621TS15

- 4-port 10/100BASE-TX
- 2-port 100BASE-FX
- Supports multi-mode fiber, 2km/15km distance
- -40 to 75 degrees C wide operating temperature
- IP30 metal case



## ISW-621TF

- 4-port 10/100BASE-TX
- 2-port 100BASE-FX SFP
- -40 to 75 degrees C wide operating temperature
- IP30 metal case



## IFGS-1022TF

- 8-port 10/100BASE-TX
- 2-port Gigabit TP/SFP combo interface
- -40~75 degrees C wide operating temperature
- IP30 metal case
- Dual DC 9~48V, AC 24V power input



## ISW-1600T

- 16-port 10/100BASE-TX
- -40 to 75 degrees C wide operating temperature
- IP30 metal case



## IFGS-1822TF

- 16-port 10/100BASE-TX
- 2-port Gigabit TP/SFP combo interface
- -40 to 75 degrees C wide operating temperature
- IP30 metal case



## IFGS-620TF/IFGS-1222TF

- 4/8-Port 10/100BASE-T
- 2-Port 10/100/1000BASE-T (IFGS-1222TF)
- 2-Port 1000BASE-X (One Key Ring supported)
- -40~75 degree C operating temperature
- Compact size metal case



# Layer 3 and Layer 2 Industrial Managed Gigabit PoE Switches

PLANET Industrial Managed PoE Switch series in-line power follows standard IEEE 802.3af, IEEE 802.3at or IEEE 802.3bt and is able to give power to PoE compliant devices at the distance up to 100 meters through the 4-pair Cat. 5/5e UTP wire. With data and Power over Ethernet from one unit, the industrial PoE series can reduce cable deployment and eliminate the need for dedicated electrical outlets on the wall, ceiling or any unreachable place. Carrying PLANET's uniquely Intelligent PoE Functions such as PoE schedule, scheduled power recycling and PD alive check, the Industrial Managed PoE Switch Series greatly enhances the efficiency of network management and helps to save power and cost for the hardened network.

## IGS-6329-8UP2S2X/ IGS-6329-8UP2S4X

- EN 61000-6-2 and EN 61000-6-4
- 8-port 10/100/1000BASE-T with 802.3bt PoE++
- 2-port 1G/2.5GBASE-X SFP
- 2-port 1G/2.5G/10GBASE-X SFP+
- 360-watt PoE budget/remote PoE power control
- 48~54V DC redundant power design
- ERPS ring supported
- L3 RIP and OSPFv2/v3 supported
- DI and DO support



## IGS-6325-24UP4X

- 24-port 10/100/1000BASE-T RJ45 with 802.3bt 95W PoE++ support
- 4-port 1G/2.5G/10GBASE-X SFP+
- Layer 3 Dynamic Routing, RIPv1/v2 and OSPFv2/v3
- Supports IEEE 1588 PTP transparent clock
- Supports G.8032 ERPS ring
- PoE budget up to 1,440W max.
- Supports intelligent PoE features including PoE scheduling, temperature threshold and PD alive check



## IGS-6325-24P4X

- 24-port 10/100/1000BASE-T
- 4-port 100/1000BASE-X SFP
- 4-port 1G/2.5G/10GBASE-X SFP+
- L3 static route and OSPFv2 supported
- 400-watt PoE budget/remote power control
- IPv6/IPv4 Web, Telnet and S NMP management
- ERPS ring supported
- -40~75 degrees C wide operating temperature



# Layer 3 and Layer 2 Industrial Managed Gigabit PoE Switches

## IGS-6325-24P4S

- 24-port 10/100/1000BASE-T
- 4-port 100/1000BASE-X SFP
- L3 static route and OSPFv2 supported
- 400-watt PoE budget/remote power control
- IPv6/IPv4 Web, Telnet and SNMP management
- ERPS ring supported
- -40~75 degrees C wide operating temperature



## IGS-R4215-24P4X

- 24-Port 10/100/1000 BASE-T RJ45 with 802.3at PoE+
- 4-Port 100/1G/2.5G/10GBASE-X SFP+
- PoE budget up to 440W max.
- USB-to-RS232 console management interface
- DI and DO supported
- ITU G.8032 ERPS ring
- Layer 3 Static route supported



## IGS-6325-16P4S

- 16-port 10/100/1000BASE-T with 802.3at PoE+
- 4-port 100/1G/2.5GBASE-X SFP
- IPv6/IPv4 Web, Telnet and SNMP management
- ERPS ring supported
- -40~75 degrees C wide operating temperature
- DI and DO supported
- L3 Static route and OSPFv2 supported



## IGS-6325-8UP2S/ IGS-6325-8UP2S2X

- 8-port 10/100/1000BASE-T with 802.3bt PoE++
- 360-watt PoE budget/remote PoE power control
- -40 ~ 75 degrees C wide operating temperature
- 48 ~ 56V DC redundant power design
- IEEE 802.1w/1s STP, IEEE 802.1Q VLAN and IGMP snooping v2 and v3
- ERPS ring supported
- L3 static route and OSPFv2 supported
- DI and DO supported



## IGS-6325-4UP2X

- 4-port 100/1G/2.5GBASE-T RJ45 with 802.3bt 95W PoE++ support
- 2-port 1G/2.5G/10GBASE-X SFP+
- Layer 3 Dynamic Routing, RIPv1/v2 and OSPFv2/v3
- Supports IEEE 1588 PTP transparent clock
- Supports G.8032 ERPS ring
- PoE budget up to 360W max.
- Supports intelligent PoE features including PoE scheduling, temperature threshold and PD alive check



## IGS-5225-8P2S2X

- 8-port 10/100/1000BASE-T with 802.3at PoE+
- 240-watt PoE budget/remote PoE power control
- -40 ~ 75 degrees C wide operating temperature
- 48 ~ 56V DC redundant power design
- IEEE 802.1w/1s STP, IEEE 802.1Q VLAN and IGMP snooping v2 and v3
- ERPS ring supported
- L3 static route and OSPFv2 supported
- DI and DO supported



## IGS-20160HPT

- 16-port 10/100/1000BASE-T with 802.3at PoE+
- 2-port 10/100/1000BASE-T
- 2-port 100/1000BASE-X SFP
- IPv6/IPv4 Web, Telnet and SNMP management
- 802.1Q VLAN, MSTP and IGMP snooping
- ERPS ring supported
- Static route supported
- -40 to 75 degrees C wide operating temperature
- DI and DO supported



## IGS-5225-8P2T2S

- 8-port 10/100/1000BASE-T with 802.3at PoE+
- 2-port 10/100/1000BASE-T
- 4-port 100/1000BASE-X SFP
- IPv6/IPv4 Web, Telnet and SNMP management
- 802.1Q VLAN, MSTP and IGMP snooping
- ERPS ring supported
- Static route supported
- -40~75 degrees C wide operating temperature
- DI and DO supported



## IGS-5225-8P4S/IGS-5225-8P2T4S

- 8-port 10/100/1000BASE-T with 802.3at PoE+
- 4-port 100/1000BASE-X SFP
- IPv6/IPv4 Web, Telnet and SNMP management
- 802.1Q VLAN, MSTP and IGMP snooping
- ERPS ring supported
- Static route supported
- -40~75 degrees C wide operating temperature
- DI and DO supported



# Layer 3 and Layer 2 Industrial Managed Gigabit PoE Switches

## IGS-5225-8P4S-12V

- 8-port 10/100/1000BASE-T with 802.3at PoE+
- 4-port 100/1000BASE-X SFP
- IPv6/IPv4 Web, Telnet and SNMP management
- 802.1Q VLAN, MSTP and IGMP snooping
- ERPS ring supported
- Static route supported
- -40~75 degrees C wide operating temperature
- DI and DO supported
- 12~54V DC redundant power



## IGS-10020HPT/IGS-10020HPT-U

- 8-port 10/100/1000BASE-T with 802.3af/at PoE+
- 2-port 100/1G/2.5GBASE-X SFP
- IPv6/IPv4 Web, Telnet and SNMP management
- 802.1Q VLAN, MSTP and IGMP snooping
- ERPS ring supported
- Static route supported
- -40 to 75 degrees C wide operating temperature
- DI and DO supported
- 12~48V DC redundant power



## IGS-10020PT

- 8-port 10/100/1000BASE-T with 802.3af/at PoE+
- 2-port 100/1G/2.5GBASE-X SFP
- IPv6/IPv4 Web, Telnet and SNMP management
- 802.1Q VLAN, MSTP and IGMP snooping
- ERPS ring supported
- Static route supported
- -40 to 75 degrees C wide operating temperature
- DI and DO supported



## IGS-5225-4UP1T2S/ IGS-5225-4UP1T2S-12V

- 4-port 10/100/1000BASE-T with 802.3bt/802.3at PoE
- 1-port 10/100/1000BASE-T
- 2-port 100/1000BASE-X SFP
- IPv6/IPv4 Web, Telnet and SNMP management
- 802.1Q VLAN, MSTP and IGMP snooping
- ERPS ring supported
- Static route supported
- -40 to 75 degrees C wide operating temperature
- DI and DO supported



## IGS-5225-4P2S

- 4-Port 10/100/1000BASE-T with 802.3at PoE+
- 2-Port 100/1000BASE-X SFP
- IPv6/IPv4 Web, Telnet and SNMP management
- 802.1Q VLAN, MSTP and IGMP snooping
- ERPS ring supported
- Static route supported
- -40~75 degrees C wide operating temperature



## IGS-4215-16P2T2S

- 16-port 10/100/1000BASE-T with 802.3at PoE+
- 2-port 100/1000BASE-T
- 2-port 100/1000BASE-X SFP
- IPv6/IPv4 Web, Telnet and SNMP management
- 802.1Q VLAN, MSTP and IGMP snooping
- -40 to 75 degrees C wide operating temperature
- ERPS Ring and Loop protection supported



## IGS-4215-8P2T2S

- 8-port 10/100/1000BASE-T with 802.3at PoE+
- 2-port 100/1000BASE-T
- 2-port 100/1000BASE-X SFP
- IPv6/IPv4 Web, Telnet and SNMP management
- 802.1Q VLAN, MSTP and IGMP snooping
- -40 to 75 degrees C wide operating temperature
- ERPS Ring and Loop protection supported



## IGS-4215-4P4T2S/IGS-4215-4P4T

- 4-port 10/100/1000BASE-T with 802.3at PoE+
- 4-port 10/100/1000BASE-T
- 2-port 100/1000BASE-X SFP (IGS-4215-4P4T2S)
- IPv6/IPv4 Web, Telnet and SNMP management
- 802.1Q VLAN, MSTP and IGMP snooping
- -40 to 75 degrees C wide operating temperature



## IGS-4215-4UP4T2S

- 4-port 10/100/1000BASE-T with 802.3bt PoE++
- 4-port 10/100/1000BASE-T
- 2-port 100/1000BASE-X SFP
- Intelligent PoE PD alive check, PoE schedule and PD scheduled reboot
- IPv6/IPv4 Web, Telnet and SNMP Management
- 802.1Q VALN, MSTP and IGMP snooping
- ERPS Ring and Loop protection supported



## IGS-4215-8UP2T2S

- 8-port 10/100/1000BASE-T with 802.3bt PoE++
- 2-port 10/100/1000BASE-T
- 2-port 100/1000BASE-X SFP
- Intelligent PoE PD alive check, PoE schedule and PD scheduled reboot
- IPv6/IPv4 Web, Telnet and SNMP Management
- 802.1Q VLAN, MSTP and IGMP snooping
- ERPS Ring and Loop protection supported



## IGS-4215-8UP4X

- 8-port 10/100/1000BASE-T RJ45 with 802.3bt 95W PoE++ support
- 4-port 1G/2.5G/10GBASE-X SFP+
- USB-to-RS232 console management interface
- Supports G.8032 ERPS ring
- IP30 aluminum case with fanless design
- Operating temperature ranges from -40 ~ 75°C
- PoE budget up to 360W max.
- Layer 3 static route supported



## IGS-4215-16P4X

- 16-port 10/100/1000BASE-T RJ45 with 802.3at 36W PoE+ support
- 4-port 1G/2.5G/10GBASE-X SFP+
- USB-to-RS232 console management interface
- Supports G.8032 ERPS ring
- IP30 aluminum case with fanless design
- Operating temperature ranges from -40 ~ 75°C
- PoE budget up to 360W max.
- Layer 3 static route supported



# Layer 2 Industrial PoE Switches/Extenders

PLANET industrial PoE switch series in-line power follows standard IEEE 802.3af, IEEE 802.3at and IEEE 802.3bt and is able to give power to PoE compliant devices at the distance up to 100 meters through the 4-pair CAT5/5e UTP wire. As un-managed industrial PoE switch offers very easy-to-use Power over Ethernet function, customer just needs to connect their PoE device to un-managed industrial PoE switch, and just plug and play.

## ISW-504PT

- 4-port 10/100BASE-TX with 802.3at PoE
- 1-port 10/100BASE-TX
- -40 to 75 degrees C wide operating temperature
- IP40 metal case
- 12~48V DC redundant power design
- 250m in distance with 25-watt power output in Extend mode



## ISW-514PTF

- 4-port 10/100BASE-TX with 802.3at PoE
- 1-port 100BASE-FX SFP
- -40 to 75 degrees C wide operating temperature
- IP40 metal case
- 12~48V DC redundant power design
- 250m in distance with 25-watt power output in Extend mode



## IFGS-624PTF

- 4-Port 10/100BASE-T with 802.3at PoE+
- 2-Port 1000BASE-X (One Key Ring supported)
- -40~75 degree C operating temperature
- Compact size metal case



## IFGS-1022HPT

- 8-port 10/100BASE-TX with 802.3at PoE+
- 2-port Gigabit TP/SFP combo for uplink
- 240-watt PoE budget
- -40 to 75 degrees C wide operating temperature
- IP30 metal case
- 250m in distance with 30-watt power output in Extend mode



## IGS-504PT/IGS-504HPT/IGS-514PT

- 4-port 10/100/1000BASE-T with 802.3at PoE+
- 1-port 10/100/1000BASE-T
- Smart PoE power usage LED indicator
- -40 to 75 degrees C wide operating temperature
- IP30 metal case



## IGS-624HPT/IGS-614HPT

- 4-port 10/100/1000BASE-T with 802.3at PoE+
- 2-port 100/1000BASE-X SFP (DIP Control)
- Dual SFP Ports Auto Link Redundant
- Mode supported (IGS-624HPT)
- Smart PoE power usage LED indicator
- -40 to 75 degrees C wide operating temperature
- IP30 metal case



## IGS-1020PTF/IGS-1020PTF-12V

- 8-port 10/100/1000BASE-T with 802.3at PoE+
- 2-port 100/1000BASE-X SFP combo for uplink
- 240-watt PoE budget
- -40 to 75 degrees C wide operating temperature
- IP30 metal case
- 12~48V DC redundant power design
- 250m in distance with 25-watt power output in Extend mode



## IGS-824UPT

- 4-port 10/100/1000BASE-T with 802.3bt PoE++
- 2-port 10/100/1000BASE-T
- 2-port 100/1000BASE-X SFP
- 240-watt PoE budget
- -40~75 degrees C operating temperature
- Supports PoH PoE and Legacy detection



## IGS-1000-4UP2X/IGS-1000-8UP4X

- 8-Port 10/100/1000BASE-T RJ45 with 802.3bt 95W PoE++ (IGS-1000-8UP4X)
- 4-Port 10/100/1000/2500BASE-T RJ45 with 802.3bt 95W PoE++ (IGS-1000-4UP2X)
- 2/4-Port 100/1G/2.5G/10GBASE-X SFP+
- PoE budget up to 360W max.
- Dual 48~54V DC redundant power
- 40~75 degree C operating temperature
- IP30 aluminum case with fanless design

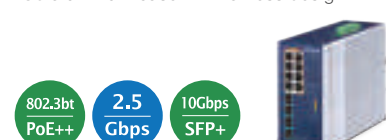

## IPOE-E302

- IP67 aluminum case, outdoor installation
- Waterproof/dustproof RJ45 Ethernet connector
- 1-port IEEE 802.3bt PoE++ PD
- 2-port IEEE 802.3at PoE PSE
- Max. total PoE budget up to 60 watts
- -40 to 75 degrees C operating temperature
- Extends Cat.5 cable installations to beyond 100 meters



## IPOE-E174

- Forwards both Ethernet data and in-line power to 4 remote devices
- 1-port ultra Power over Ethernet PD
- 4-port IEEE 802.3af/at Power over Ethernet/end-span PSE
- Supports PoE output power up to 30.8 watts for each PoE port
- Extends the range of PoE for an additional 100 meters (328ft.)
- -40 to 75 degrees C wide operating temperature



## WGS-E304PT

- Forwards both Ethernet data and in-line power to 4 remote devices
- 1-port ultra Power over Ethernet PD
- 4-port IEEE 802.3af/at Power over Ethernet/end-span PSE
- Supports PoE output power up to 30.8 watts for each PoE port
- Extends the range of PoE for an additional 100 meters (328ft.)
- -40 to 75 degrees C wide operating temperature



# EN50155 ITS Ethernet Network Solution



## ITS-6326 Series

- Compliance with Railway Certification EN 50155
- Up to 16-port 10/100/1000BASE-T M12 X-coded with 802.3at PoE+
- Up to 2-port 1G/2.5G/5G/10GBASE-T M12 X-coded
- Up to 2-port 10GBASE-X Q-ODC connector slot
- 16.8~137.5V Dual DC power design
- Up to 100-watts PoE budget
- Bypass relay prevents link failure during power loss
- Layer 3 Dynamic Routing, RIPV1/v2 and OSPFV2/v3
- Supports IEEE 1588 PTP transparent clock
- ERPS ring supported
- -40 to 70 degree C wide operating temperature



## IGS-5227X-4P2T

- IP67 aluminum case, outdoor installation
- Waterproof and dustproof M12 Ethernet connector against vibration and shock
- -40 to 75 degrees C wide operating temperature
- 12~48V DC redundant power design
- 144-watt PoE budget/remote PoE power control
- PoE schedule, scheduled power recycling and PD alive check functions
- ERPS Ring Data Recovery time < 50ms
- IPv4/IPv6 Layer 3 static routing and route summarization



## IGS-604HPT-M12/IGS-604HPT-RJ

- IP67 aluminum case, outdoor installation
- Waterproof/dustproof M12/RJ45 Ethernet connector
- 4-port 10/100/1000BASE-T with 802.3at PoE+
- 2-port 10/100/1000BASE-T
- 48~56V DC redundant power design
- Up to 144-watts PoE budget
- -45 to 70 degree C wide operating temperature
- IPv6 and IPv4 Web, Telnet and SNMP management
- ERPS ring supported
- Layer 3 static route supported



## IGS-5226-4P2T

- IP50 metal case
- IEEE 1588 and synchronous Ethernet network timing
- IPv6/IPv4 Layer 3 static routing and route summarization
- 144-watt PoE budget, remote PoE power control
- 48~56V DC redundant power design
- ERPS Ring Data Recovery time < 50ms
- -40 to 75 degrees C wide operating temperature



## IGS-5227-6MT-X

- IP67 aluminum case, outdoor installation
- Waterproof and dustproof M12 Ethernet connector against vibration and shock
- -40 to 75 degrees C wide operating temperature
- 12~48V DC redundant power design
- ERPS Ring Data Recovery time < 50ms
- IPv4/IPv6 Layer 3 static routing and route summarization



## IGS-5227-6T

- IP67 aluminum case, outdoor installation
- Waterproof/dustproof RJ45 Ethernet connector
- 6-port 10/100/1000BASE-T
- IPv6 and IPv4 Web, Telnet and SNMP management
- 802.1Q VLAN, MSTP and IGMP snooping
- ERPS ring supported
- Static route supported
- -40 to 75 degrees C wide operating temperature



## WGS-5225-8MT

- IP30 metal case, flat-type design
- Dustproof M12 Ethernet connector against vibration and shock
- 8-port 10/100/1000BASE-T
- Bypass relay prevents link failure during power loss
- 9~48V DC redundant power design
- ERPS ring supported
- Layer 3 static route supported



## ISW-808PT-M12A/ ISW-808PT-M12

- 8-port 10/100BASE-TX with 802.3af/at PoE
- IP67 aluminum case
- Robust M12 Ethernet connector
- -40 to 75 degrees C wide operating temperature



## ISW-800T-M12

- 8-port 10/100BASE-TX
- IP67 aluminum case
- Robust M12 Ethernet connector
- Waterproof and dustproof
- -40 to 75 degrees C wide operating temperature



# Layer 3 and Layer 2 Industrial Flat-type Ethernet Switches

## WGS-6325-8UP2X

- 4-port 10/1G/2.5GBASE-T RJ45 with 802.3bt PoE++
- 4-port 10/100/1000BASE-T RJ45 with 802.3bt PoE++
- 2-port 1G/2.5G/10GBASE-X SFP+
- 95W output per PoE++ port, up to total 480W PoE budget
- Layer 3 Dynamic Routing, RIPv1/v2 and OSPFv2/v3
- 1588 PTP transparent clock supported
- G.8032 ERPS ring supported
- PoE schedule, scheduled power recycling and PD alive check



## WGS-5225-8UP2SV

- 2.4-inch color LCD touch screen with management function
- 8-port 10/100/1000BASE-T with 802.3bt PoE++
- 2-port 100/1G/2.5GBASE-X SFP
- 720-watt PoE budget
- ERPS ring supported
- Layer 3 static route supported
- PoE schedule, scheduled power recycling, PD alive check



## WGS-5225-8P2S/WGS-5225-8P2SV

- 2.4-inch color LCD touch screen with management functions (WGS-5225-8P2SV)
- 8-port 10/100/1000BASE-T with 802.3at PoE+
- 2-port 100/1G/2.5GBASE-X SFP
- 802.1Q VLAN, MSTP and IGMP Snooping
- ERPS ring and IEEE 1588 supported
- Static route supported
- Modbus TCP
- PoE schedule, scheduled power recycling, PD alive check



## WGS-5225-8T2SV

- 2.4-inch color LCD touch screen with management functions
- 8-port 10/1G/2.5G/1000BASE-T
- 2-port 100/1G/2.5GBASE-X SFP
- 802.1Q VLAN, MSTP and IGMP Snooping
- ERPS ring and IEEE 1588 supported
- Static route supported
- Modbus TCP



## WGS-5225-8MT

- IP30 metal case, flat-type design
- Dustproof M12 Ethernet connector against vibration and shock
- 8-port 10/100/1000BASE-T
- Bypass relay prevents link failure during power loss
- 9~48V DC redundant power design
- ERPS ring supported
- Layer 3 static route supported



## WGS-4215-8P2X/WGS-4215-8P2XV

- 2.4-inch color LCD touch screen with management functions (WGS-4215-8P2XV)
- 8-Port 10/100/1000/2500BASE-T RJ45 with 802.3at PoE+
- 2-Port 100/1G/2.5G/10GBASE-X SFP+
- PoE budget up to 288W max.
- Dual 48~54V DC redundant power
- ITU G.8032 ERPS ring
- Layer 3 Static route supported



## WGS-4215-16P2S

- 16-port 10/100/1000T with 802.3at PoE+
- 2-port 100/1000X SFP
- -10 to 60 degrees C wide operating temperature
- 48~54V DC dual power input
- 240-watt PoE budget, up to 16 PoE port
- PD alive check, scheduled power recycling and time-based PoE schedule
- IPv6 and IPv4 Web; Telnet; SNMPv1, v2c, v3; SSHv2/TLSv1.2 management
- QoS, bandwidth control, storm control, Layer 3/4 access control list
- STP/RSTP/MSTP, LACP



## WGS-4215-8HP2S/WGS-4215-8P2S

- 4/8-port 10/100/1000BASE-T RJ45 with 802.3at PoE+
- 4-port 10/100/1000BASE-T RJ45 with 802.3bt 95W PoE++ (WGS-4215-8HP2S)
- 2-Port 100/1GBASE-X SFP
- Up to 200/360-watts PoE budget
- ERPS ring supported
- PoE schedule, schedule power recycling, PD alive check
- IPv6/IPv4 Web; Telnet; SNMPv1, v2c, v3; SSHv2/TLSv1.2 management



## WGS-4215-8T2S/WGS-4215-8T

- 8-port 10/100/1000BASE-T
- 2-port 100/1000BASE-X SFP (WGS-4215-8T2S)
- -40 to 75 degrees C wide operating temperature
- 24V AC and 12~48V DC redundant power
- Compact size, magnetic wall mount and DIN-rail design
- IPv6 and IPv4 Web, Telnet and SNMP management
- 802.1Q VLAN, MSTP and IGMP snooping





**WGS-804HPT**

- 4-port 10/100/1000BASE-T with 802.3at PoE+
- 4-port 10/100/1000BASE-T
- -40 to 75 degrees C wide operating temperature
- 48~54V DC redundant power
- Compact size, magnetic wall mount and DIN-rail design
- IPv6 and IPv4 Web, Telnet and SNMP management
- 802.1Q VLAN, MSTP and IGMP snooping
- LED indicators for PoE usage and status

**WGS-818HP/WGS-814HP  
WGS-804HP**

- 4-port 10/100/1000BASE-T with 802.3at PoE+
- 4-port 10/100/1000BASE-T
- -10 to 60 degrees C operating temperature
- 48~56V DC redundant power
- Compact size, magnetic wall mount and DIN-rail design
- LED indicators for PoE usage and status
- 250m in distance in Extend mode

**WGS-803/WGS-810**

- 8-port 10/100/1000BASE-T
- -10 to 60 degrees C operating temperature
- 24V AC and 12~48V DC redundant power
- Compact size, magnetic wall mount and DIN-rail design
- 250m in distance in Extend mode

**Industrial Flat-type Gigabit Routers****WGR-500-4P**

- 4-port 10/100/1000BASE-T with 802.3at PoE+
- 802.1Q VLAN and IGMP proxy
- PoE schedule, scheduled power recycling, PD alive check
- IPv6 support for IoT Networking
- Secure firewall protection
- VLAN support for isolated traffic and security

**Renewable Energy PoE Switches & Management Controller Series****BSP-360**

- 4-port 10/100/1000BASE-T with 802.3at PoE+
- 1-port 10/100/1000BASE-T WAN
- 1 24V DC power output terminal block
- -10~60 degrees C operating temperature
- MPPT Charge Controller
- Supports Lithium and Lead-acid Battery

**BSP-115HP-5A/BSP-115PV-15A**

- 1-port 10/100/1000BASE-T RJ45 with 802.3bt PoE++ (BSP-115HP-5A)
- 2/5-port 10/100/1000BASE-T RJ45 with 802.3at PoE+
- 2-port 10/100/1000BASE-T RJ45 with 24/48V Passive PoE (BSP-115HP-5A)
- Up to 65/120-watts PoE budget
- MPPT Charge Controller
- Supports Lithium, Lithium Iron Phosphate and Lead-acid Battery

**NMS-360/NMS-360V**

- Auto discovery of up to 512 BSP-360 switches and up to 2048 PoE IP cameras
- Central provisioning and remotely control over each managed device
- Dashboard for Green Power, PoE Usage, Traffic and Device Event
- Setup Wizard, and e-mail alarm notification
- Map viewing and IP cam snapshots
- Backup and restoration via USB 3.0
- Stylish 10" TFT-LCD touch screen display (NMS-360V)

**NMS-360 Series Intuitive Management Interface**

Dashboard



Device List



Device Information

# Renewable Energy Off-Grid PoE+ Network System Application

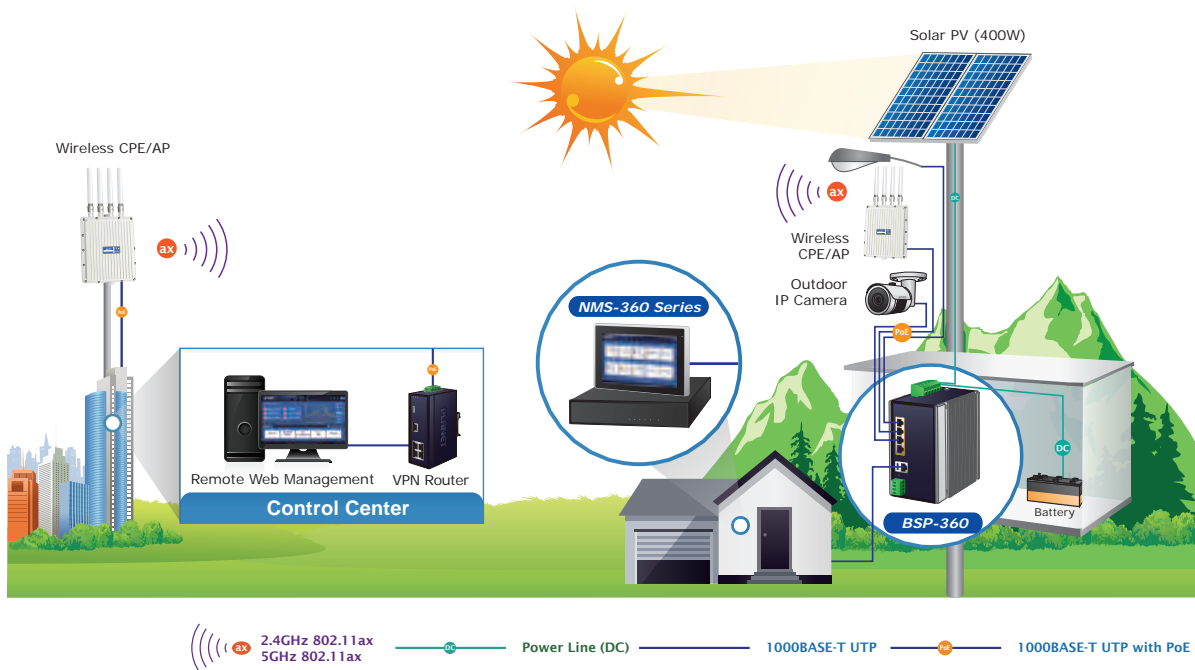

## Industrial PoE Injectors & Splitters

### IPOE-162

- 10/100/1000BASE-T
- Distance up to 100m with 30W power output
- -40 to 75 degrees C wide operating temperature
- 12~48V DC redundant power
- IP30 metal case



### IPOE-162S

- 10/100/1000BASE-T
- 12/24V DC power output by DIP switch
- -40 to 75 degrees C wide operating temperature
- IP30 metal case



### IPOE-171-60W

- 10/100/1000BASE-T
- Distance up to 100m with 60W power output
- -40 to 75 degrees C wide operating temperature
- IP30 metal case



### IPOE-171-95W

- 10/100/1000BASE-T
- Distance up to 100m with 95W power output
- -40 to 75 degrees C wide operating temperature
- IP30 metal case



### IPOE-173S

- Compliant with 802.3bt PoE++ PD
- 10/100/1000BASE-T
- 12/19/24V DC power output by DIP switch
- -40 to 75 degrees C wide operating temperature
- IP30 metal case



### IPOE-176S

- Compliant with 802.3bt PoE++ PD
- 100/1G/2.5G/5G/10GBASE-T
- 12/19/24V DC power output by DIP switch
- -40 to 75 degrees C wide operating temperature
- IP30 metal case



### IPOE-175

- Up to 60 watts of PoE power on 4-pair UTP
- Data and power over one Ethernet cable up to 100 meters
- IP67 and IK10-rated aluminum case
- -40~75 degrees C wide operating temperature
- 24~56V DC to 55V power boost technology



### IPOE-175S

- Supports 12V DC, 60-watt power output
- IP67 and IK10-rated aluminum case
- -40~75 degrees C wide operating temperature
- Compliant with IEEE 802.3bt PoE++ PD
- Supports 10/100/1G applications



### IPOE-165

- Up to 30 watts of PoE power on UTP
- Data and power over one Ethernet cable up to 100 meters
- IP67 and IK10-rated aluminum case
- -40~75 degrees C wide operating temperature
- 24~56V DC to 54V power boost technology



### IPOE-260/IPOE-260-12V

- 10/100/1000BASE-T "Data" input port x 2
- 10/100/1000BASE-T "Data + Power" output port x 2
- -40 to 75 degrees C operating temperature
- IP30 metal case, DIN-rail and wall-mountable



### IPOE-270/IPOE-270-12V

- 10/100/1G/2.5G/5GBASE-T "Data" input port x 2
- 10/100/1G/2.5G/5GBASE-T "Data + Power" output port x 2
- Up to 90-watt of PoE power on 4-pair UTP
- 180-watt PoE budget
- -40~75 degrees C wide operating temperature
- IP30 metal case, DIN-rail and wall-mountable



### IPOE-470/IPOE-470-12V

- 10/100/1G/2.5GBASE-T "Data" input port x 4
- 10/100/1G/2.5GBASE-T "Data + Power" output port x 4
- Up to 95-watt of PoE power on 4-pair UTP
- 240-watt PoE budget
- -40~75 degrees C wide operating temperature
- IP30 metal case, DIN-rail and wall-mountable

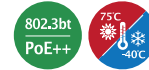

## Industrial PoE Media Converters

PLANET Industrial PoE Media Converter series combines Ethernet media conversion (from 1000BASE-X to 10/100/1000BASE-T) with 802.3at PoE+ injector delivered in an IP30 rugged strong case. With data and power over Ethernet from one unit, the Industrial PoE Media Converter series can reduce cable deployment and eliminate the need for dedicated electrical outlets on the wall, ceiling or any unreachable place.

### IGTP-802T/IGTP-802TS

- 1-port 10/100/1000BASE-T 802.3at PoE+
- 1-port 1000BASE-SX multi-mode , 220/550 meters (IGTP-802T)
- 1-port 1000BASE-LX single mode, 10km (IGTP-802TS)
- -40 to 75 degrees C wide operating temperature.
- IP30 metal case
- 12~48V DC redundant power



### IGTP-805AT/IGTP-815AT

- 1-port 10/100/1000BASE-T 802.3at PoE+
- 1-port 100/1000BASE-X SFP
- -40 to 75 degrees C wide operating temperature.
- Compact IP30 metal case
- 12~48V DC power input (IGTP-805AT)
- 48~54V DC power input (IGTP-815AT)



### IGTP-825AT

- 1-port 10/100/1000BASE-T 802.3at PoE+
- 1-port 1000BASE-X SFP
- Up to 30 watts of PoE power on UTP
- IP67 and IK10-rated aluminum case
- -40~75 degrees C wide operating temperature
- 24~56V DC to 54V power boost technology



### IGTP-2205AT

- 2-port 10/100/1000BASE-T 802.3at PoE+
- 2-port 100/1000BASE-X SFP
- -40 to 75 degrees C wide operating temperature.
- Compact IP30 metal case
- 48~54V DC power input



### IGUP-805AT

- 1-port 10/100/1000BASE-T 802.3bt PoE++ type-4 PSE
- 1-port 100/1000BASE-X SFP
- -40 to 75 degrees C wide operating temperature.
- 12~54V DC redundant power
- DIP switch for 802.3bt/PoH/Force mode control
- DIP switch for Link Fault Passthrough PoE control



### IGUP-1205AT/IGUP-2205AT

- 1-/2-port 10/100/1000BASE-T 802.3bt PoE++ type-4 PSE
- 2-port 100/1000BASE-X SFP
- -40 to 75 degrees C wide operating temperature.
- 12~54V DC redundant power
- 90W/180W PoE budget
- DIP switch for 802.3bt/Legacy/Force mode control



# Industrial Fiber over Ethernet Media Converters

PLANET Industrial Fiber over Ethernet Media Converter Solution is designed to withstand extreme temperatures to ensure stable operations in harsh industrial conditions. It also provides the dynamic status report and real-time alarm messages that make monitoring and managing the entire industrial networks easy.

PLANET provides the Industrial Media Converters with various fiber-optic interfaces to convert signals via 10G, Gigabit, and Fast Ethernet ports.

- IXT series – allows the signal to convert between fiber-optic interface and 10G port
- IGT series – allows the signal to convert between fiber-optic interface and Gigabit Ethernet port
- IFT series – allows the signal to convert between fiber-optic interface and Fast Ethernet port

# Industrial 10GBASE-X Fiber over Ethernet Media Converters

## IXT-900-1X1T

- 1-port 100/1G/2.5G/5G/10GBASE-T RJ45
- 1-port 100/1G/2.5G/10GBASE-X SFP+ slot
- IEEE 802.1Q VLAN and IEEE 802.1ad Q-in-Q VLAN mode
- Supports ITU-G.8032 ERPS
- QoS supports IP TOS / DSCP / IP Precedence
- PLANET NMS system and CloudViewerPro for remote management



## IXT-900-2X

- 2-port 100/1G/2.5G/10GBASE-X SFP+ slot
- IEEE 802.1Q VLAN and IEEE 802.1ad Q-in-Q VLAN mode
- Supports ITU-G.8032 ERPS
- QoS supports IP TOS / DSCP / IP Precedence
- PLANET NMS system and CloudViewerPro for remote management



## IXT-900-2X1T

- 1-port 100/1G/2.5G/5G/10GBASE-T RJ45
- 2-port 100/1G/2.5G/10GBASE-X SFP+ slot
- IEEE 802.1Q VLAN and IEEE 802.1ad Q-in-Q VLAN mode
- Supports ITU-G.8032 ERPS
- QoS supports IP TOS / DSCP / IP Precedence
- PLANET NMS system and CloudViewerPro for remote management



## IXT-900-2X1PD

- 1-port 100/1G/2.5G/5G/10GBASE-T RJ45 with optional PoE input support
- 2-port 100/1G/2.5G/10GBASE-X SFP+ slot
- IEEE 802.1Q VLAN and IEEE 802.1ad Q-in-Q VLAN mode
- Supports ITU-G.8032 ERPS
- QoS supports IP TOS / DSCP / IP Precedence
- PLANET NMS system and CloudViewerPro for remote management



## IXT-900-2X1UP

- 1-port 100/1G/2.5G/5G/10GBASE-T RJ45
- 2-port 100/1G/2.5G/10GBASE-X SFP+ slot
- IEEE 802.1Q VLAN and IEEE 802.1ad Q-in-Q VLAN mode
- Supports ITU-G.8032 ERPS
- QoS supports IP TOS / DSCP / IP Precedence
- PLANET NMS system and CloudViewerPro for remote management



## IXT-900-1X1UP

- 1-port 100/1G/2.5G/5G/10GBASE-T RJ45
- 1-port 100/1G/2.5G/10GBASE-X SFP+ slot
- IEEE 802.1Q VLAN and IEEE 802.1ad Q-in-Q VLAN mode
- Supports ITU-G.8032 ERPS
- QoS supports IP TOS / DSCP / IP Precedence
- PLANET NMS system and CloudViewerPro for remote management



## IXT-705AT

- Complies with IEEE 802.3ae 10GBASE-R
- NBASE-T featuring adaptive rate operation
- 100 meters over Cat 6A at 10Gbps
- -40~75 degrees C wide operating temperature
- IP30 metal case
- Low power consumption



# Industrial 1000BASE-X Fiber over Ethernet Media Converters

## IGT-900-1T1S

- 1-port 10/100/1000BASE-T
- 1-port 100/1G/2.5GBASE-X SFP
- 9~48V DC redundant power design
- -40~75 degrees C operating temperature
- 802.1Q VLAN, MSTP and IGMP snooping
- ERPS Ring and Loop protection supported
- IPv6/IPv4 Web/TLS; Telnet/SSHv2; SNMPv1/v2c/v3 management



## IGT-900-2T2S

- 2-port 10/100/1000BASE-T
- 2-port 100/1G/2.5GBASE-X SFP
- 9~48V DC redundant power design
- -40~75 degrees C operating temperature
- 802.1Q VLAN, MSTP and IGMP snooping
- ERPS Ring and Loop protection supported
- IPv6/IPv4 Web/TLS; Telnet/SSHv2; SNMPv1/v2c/v3 management



## IGT-805AT

- 1-port 100/1000BASE-X SFP fiber optic
- 1-port 10/100/1000BASE-T
- 12~48V DC redundant power
- -40 to 75 degrees C operating temperature
- IP30 metal case



## IGT-815AT

- 1-port 100/1000BASE-X SFP fiber optic
- 1-port 10/100/1000BASE-T
- 12~48V DC redundant power
- -40 to 75 degrees C operating temperature
- IP30 metal case



## IGT-1205AT

- 2-port 100/1G/2.5GBASE-X SFP fiber optic
- 1-port 10/100/1000BASE-T
- 12~48V DC redundant power
- -40 to 75 degrees C operating temperature
- IP30 metal case



## IGT-2205AT

- 2-port 100/1G/2.5GBASE-X SFP fiber optic
- 2-port 10/100/1000BASE-T
- 12~48V DC redundant power
- -40 to 75 degrees C operating temperature
- IP30 metal case



# Industrial 100BASE-FX Fiber over Ethernet Media Converters

## IFT-802T

- 1-port 100BASE-FX SC multi-mode, 2km fiber optic
- 1-port 10/100BASE-TX
- 12~48V DC redundant power
- -40 to 75 degrees C wide operating temperature
- IP30 metal case



## IFT-802TS15

- 1-port 100BASE-FX SC single mode, 15km fiber optic
- 1-port 10/100BASE-TX
- 12~48V DC redundant power
- -40 to 75 degrees C wide operating temperature
- IP30 metal case



## IFT-805AT

- 1-port 100BASE-FX SFP fiber optic
- 1-port 10/100BASE-TX
- 12~48V DC redundant power
- -40 to 75 degrees C wide operating temperature
- IP30 metal case



# Industrial Cellular Gateway

## ICG-2515-NR/ICG-2515F-NR

- Global 5G NR (NSA/SA)/4G LTE network with dual SIM design for cellular network redundancy
- 4 10/100/1000T LAN ports and 1 10/100/1000T WAN port
- 2 DI/DO ports and 1 serial port (RS485) for Modbus applications
- Easy management (Setup Wizard, DHCP Server and Dashboard)
- Full security with VLAN, NAT, DMZ, routing, firewall and IP/MAC/port filtering
- -45 to 75 degrees C operating temperature, DIN-rail and fanless design
- 1 1000 BASE-X SFP WAN/LAN port for long distance extensor (ICG-2515F-NR)



## ICG-2515W-NR/ICG-2515FW-NR

- Global 5G NR (NSA/SA)/4G LTE network with dual SIM design for cellular network redundancy
- 4 10/100/1000T LAN ports and 1 10/100/1000T WAN port
- 802.11ax 1800AX dual band WiFi
- 2 DI/DO ports and 1 serial port (RS485) for Modbus applications
- Full security with VLAN, NAT, DMZ, routing, firewall and IP/MAC/port filtering
- -45 to 75 degrees C operating temperature, DIN-rail and fanless design
- 1 1000 BASE-X SFP WAN/LAN port for long distance extensor (ICG-2515FW-NR)



## ICG-2210W-NR

- 5G NR(NSA/SA)/4G LTE network with dual micro-SIM design for cellular network redundancy
- Multi VPN with IPSec, OpenVPN, PPTP, L2TP, GRE
- Full security with Cybersecurity, VLAN, NAT, DMZ, and IP/MAC/Port filtering
- Stateful Packet Inspection (SPI) firewall and content filtering
- IP30 Metal and compact design
- -40 to 75 degrees C operating temperature



## FWA-2100-NR

- 5G NR(NSA/SA)/4G LTE network with dual nano-SIM design for cellular network redundancy
- SSL VPN and robust hybrid VPN (IPSec/PPTP/L2TP)
- Full security with Cybersecurity, DMZ, and IP/MAC/Port filtering
- Stateful Packet Inspection (SPI) firewall and content filtering
- -20 to 60 degrees C operating temperature
- IP68 rating waterproof

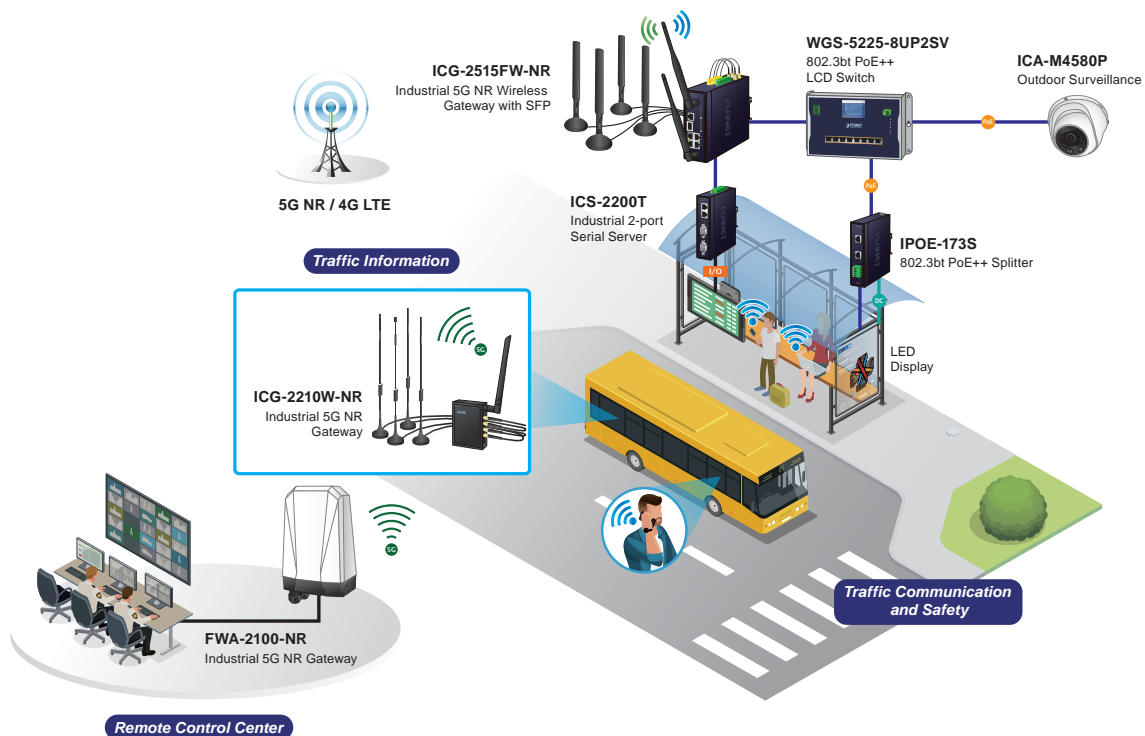



# Industrial Cellular Gateway

## ICG-2510W-LTE

- 5-port Gigabit Ethernet, build in redundancy protocol-VRRP
- 2 DI/DO and 1 serial port (RS232 or RS485) for Modbus applications
- Dual module SIM for network load balancing and redundancy
- WiFi compliance IEEE 802.11b/g/n/ac dual-band for mobile client connectivity
- Multiple VPN with IPSEC, OpenVPN, PPTP, L2TP, GRE and VPN Failover
- Full security with VLAN, NAT,DMZ, Static routing, Firewall and IP/MAC/Port filtering
- Supports CMS for remote management
- -35 to 70 degrees C operating temperature and fanless design

## ICG-2510WG-LTE

- 5-port Gigabit Ethernet, build in redundancy protocol-VRRP
- 2 DI/DO and 1 serial port (RS232 or RS485) for Modbus applications
- Dual module SIM for network load balancing and redundancy
- WiFi compliance IEEE 802.11b/g/n/ac dual-band for mobile client connectivity
- GPS antenna allows to detect the location via sat nav system
- Multiple VPN with IPSEC, OpenVPN, PPTP, L2TP, GRE and VPN Failover
- Full security with VLAN, NAT,DMZ, Static routing, Firewall and IP/MAC/Port filtering
- Supports CMS for remote management
- -35 to 70 degrees C operating temperature and fanless design

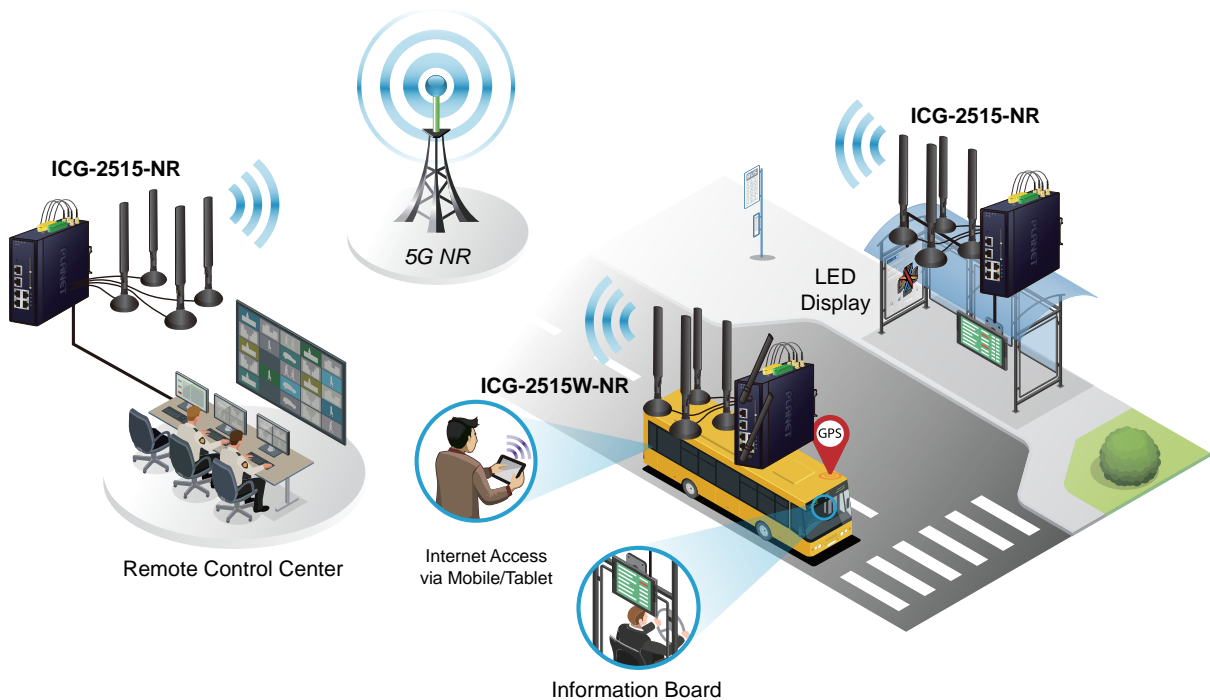

# Vehicle 4G LTE Cellular Wireless Gateway

## VCG-1500WG-LTE

- 4 10/100TX LAN ports and 1 10/100TX WAN port
- Industrial power with wide DC voltage power supply design
- One SIM slot and one 4G LTE antenna for network connection
- Supports Wi-Fi 802.11 b/g/n for mobile client connectivity
- GPS antenna allows to detect the location via sat nav system
- Supports GRE, PPTP, IPSec and L2TP
- Supports NAT, DMZ, MAC/Application/IP filter and static routing
- Supports DHCP server/client, PPPoE, static IP and DDNS
- -25 to 65 degrees C operating temperature
- Supports CMS and SNMP for remote management

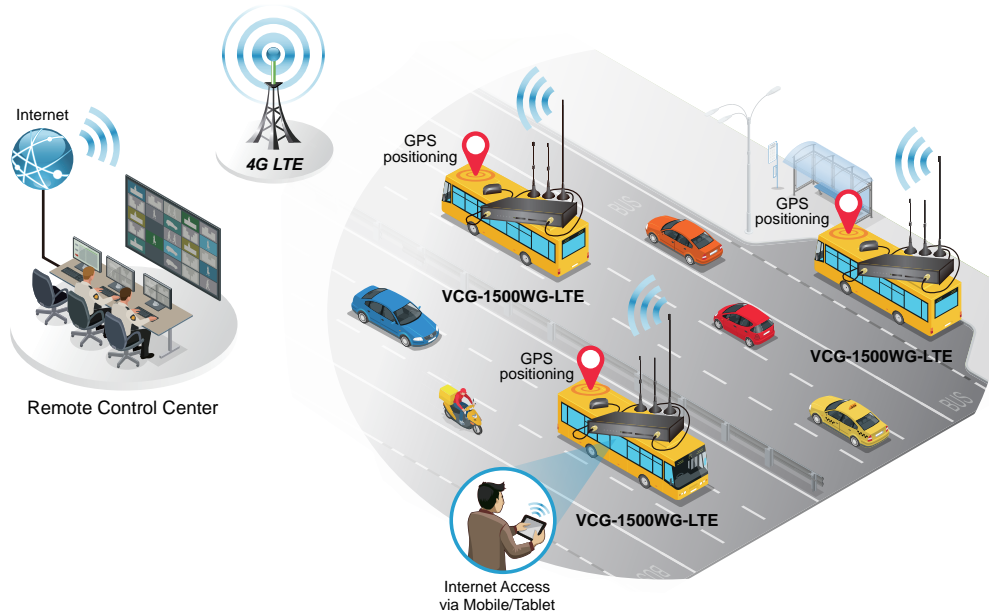

# DIN-rail Power Supplies



## PWR-40-24/PWR-60-24

- 100~240V AC, 50/60Hz, 1.1A input voltage
- Power output 40 watts/60 watts, 24V, 1.7A, 2.5A
- DIN rail TS-35/7.5 or 15
- -20 ~ 70 degrees C operating temperature



## PWR-120-48

- 100~240V AC, 50/60Hz, 2.25A input voltage
- Power output 120 watts, 48V, 2.5A
- DIN rail TS-35/7.5 or 15
- -20 ~ 70 degrees C operating temperature



## PWR-75-48

- 100~240V AC, 50/60Hz, 1.45A input voltage
- Power output 75 watts, 48V, 1.6A
- DIN rail TS-35/7.5 or 15
- -20 ~ 70 degrees C operating temperature



## PWR-480-48

- 100~240V AC, 50/60Hz, 4.8A input voltage
- Power output 480 watts, 48V, 10A
- DIN rail TS-35/7.5 or 15
- -20 ~ 70 degrees C operating temperature



## PWR-240-48

- 100~240V AC, 50/60Hz, 2.5A input voltage
- Power output 240 watts, 48V, 5A
- DIN rail TS-35/7.5 or 15
- -20 ~ 70 degrees C operating temperature



## PWR-960-48

- Input Voltage: 200 ~ 240V AC, 50/60Hz, 6A
- Power output: 960 watts, 48V, 20A
- DIN- rail TS-35/7.5 or 15
- -30 ~ 70°C operating temperature



## PWR-75-24

- 100~240V AC, 50/60Hz, 2A input voltage
- Power output 75 watts, 24V, 3.2A
- DIN rail TS-35/7.5 or 15
- -10 ~ 60 degrees C operating temperature







# Industrial Automation

## Realizing Connection to the IoT



RS232



RS485/RS422

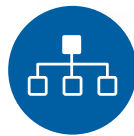

Modbus TCP



Web Management

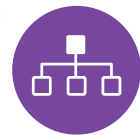

Modbus  
RTU/ASCII

### Realizing Connectivity to the IoT

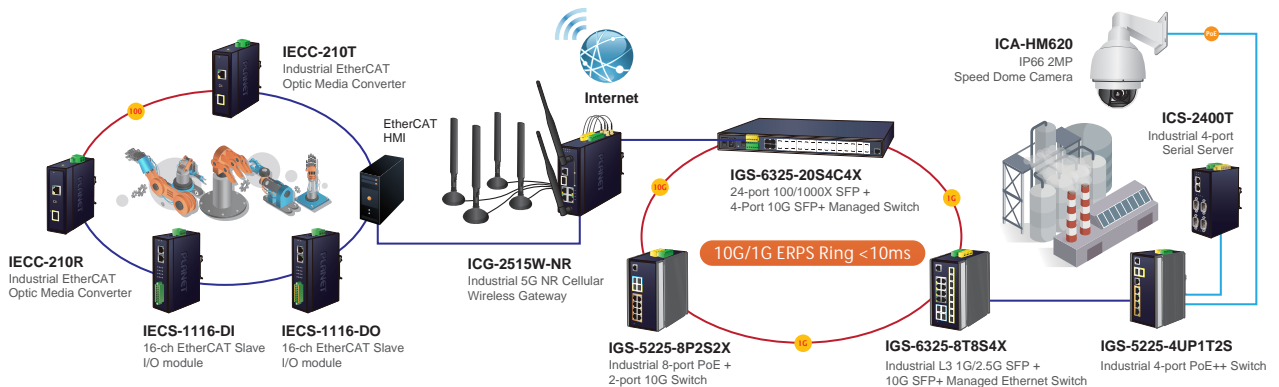

### Remote Management



Web Browser

Telnet

MB VCOM Utility

TCP/IP

# Industrial Automation

## Industrial Automation and Data Exchange for Industrial 4.0 Infrastructure

PLANET ICS Serial Device Server Series is specially designed to convert RS232, RS422 or RS485 serial communication to IoT and TCP/IP networking. It makes the connected legacy serial devices become IP-based facilities and is able to connect to the industrial Ethernet network allowing serial and Ethernet communications to connect efficiently and inexpensively. The ICS Series is a time-saving and cost-effective solution with no need of replacing the existing serial equipment and software system.



## Modbus TCP Enables Flexible Network

With the supported Modbus TCP/IP protocol, PLANET Modbus TCP Ethernet Switches can easily integrate with SCADA systems, HMI systems and other data acquisition systems in factory floors. It enables administrators to remotely monitor the industrial Ethernet switch's operating information, port information and communication status, thus achieving enhanced monitoring and maintenance of the entire factory.

## Powering the Digital Transformation with EtherCAT

PLANET IECS Series is industrial EtherCAT slave I/O modules equipped with the EtherCAT protocol for today's distributed industrial applications which provides high-density digital input/output channels and is protected with 3750V DC isolation. Its compact size and DIN-rail mounting make installation in a cabinet easy and pluggable terminal blocks and LED indicator help users to maintain and set up their system.



**EtherCAT** 

# Industrial EtherCAT Slave IO Module

## IECS-1116-DI

- Built-in isolated 16 digital inputs
- 2 x RJ45 bus interface
- LED indicators for the input status
- Removable terminal block connector
- Distance between stations up to 100m (100BASE-TX)
- EtherCAT conformance test tool verified



## IECS-1116-DO

- Built-in isolated 16 digital outputs
- 2 x RJ45 bus interface
- LED indicators for the output status
- Removable terminal block connector
- Distance between stations up to 100m (100BASE-TX)
- EtherCAT conformance test tool verified

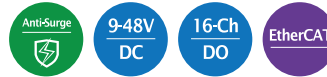

## IECC-210-KIT

- 100BASE-FX SFP interface for extended distance
- With power redundancy
- Compact size and DIN-rail or Wall Mounting
- Wide input voltage range (9 ~ 48V DC)
- EtherCAT Distributed Clock (DC) mode
- EtherCAT conformance test tool verified



## IECJ-300/400/410FT

- Multi 100BASE-TX RJ45 bus interfaces
- Three 100BASE-TX RJ45 bus interfaces and one 100BASEFX SFP interface
- Dual 9 ~ 48V DC wide input voltage range
- -40 to 75 degrees C operating temperature
- Compact size, DIN-rail mounting and wall mounting
- EtherCAT Distributed Clock (DC) mode
- EtherCAT conformance test tool verified



# Industrial RS232/RS485/RS422 over Ethernet Media Converters

PLANET Layer 2 Industrial Serial over Ethernet, with model names starting with ICS series, mean the signal converts between RS232/485/422 interface and Ethernet port or fiber-optic port. It also provides the dynamic status report and real-time alarm messages that are easy to monitor and manage the entire industrial networks.

## ICS-2105AT/ICS-2102T/ICS-2102TS

- 1 RS232 with DB9 interface
- 1 RS422 or RS485 with terminal block interface
- Choice of fiber-connector from SC/LC, multi-mode/single mode fiber
- Built-in IP-based Web interface and Telnet interface
- Several serial operating modes

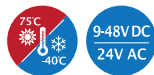

## ICS-2100T

- 1-port 10/100BASE-TX
- 1 RS232 with DB9 interface
- 1 RS422 or RS485 with terminal block interface
- Built-in IP-based Web interface and Telnet interface
- Several operating modes

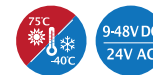

## ICS-2200T

- 2-port 10/100BASE-TX
- 2 RS232/RS422/RS485 with DB9
- 12~48V DC redundant power
- IP30 metal case



## ICS-2400T

- 2-port 10/100BASE-TX
- 4 RS232/RS422/RS485 with DB9
- 12~48V DC redundant power
- IP30 metal case





## Industrial RS422/RS485 Modbus Gateway

To fulfill the demand of automation and data exchange for industrial 4.0 infrastructures, PLANET IMG serial Modbus Gateway can act as a conversion bridge between the industrial equipment with the Modbus RTU/ASCII Protocol and the administrator workstations that run the Modbus TCP/IP Protocol.

### IMG-2100T

- 1-port 10/100BASE-TX
- 1 RS232 with DB9 interface
- 1 RS422 or RS485 with terminal block interface
- RTU Master/Slave, ASCII Master/Slave
- Built-in IP-based Web interface and telnet interface

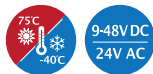

### IMG-2105AT/IMG-2102T/IMG-2102TS

- 1 RS232 with DB9 interface
- 1 RS422 or RS485 with terminal block interface
- Choice of fiber-connector from SC/LC, multi-mode/single mode fiber
- RTU Master/Slave, ASCII Master/Slave
- Built-in IP-based Web interface and telnet interface

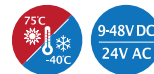

### IMG-2200T

- 2-port 10/100BASE-TX
- 2 RS232/RS422/RS485 with DB9 interface
- Built-in IP-based Web interface and telnet interface for remote management
- RTU Master/Slave, ASCII Master/Slave
- 12 to 48V DC, redundant power design



### IMG-2400T

- 2-port 10/100BASE-TX
- 4 RS232/RS422/RS485 with DB9 interface
- RTU Master/Slave, ASCII Master/Slave
- Supports 32 TCP Master and Slave connection requests
- DI/DO external alarm



## Serial over Fast Ethernet Media Converters







### ICS-110/ICS-115A/ICS-120

- Serial RS232/422/485 over IP Ethernet Solution
- Asynchronous serial data rate up to 921kbps
- Data modes include VCOM, RFC2217, TCP Server, TCP Client, UDP, Remote Pair Serial Telnet and Modbus converter
- IPv4/IPv6 Web and telnet remote management
- -10~60 degrees C operating temperature





# Comprehensive AIoT Solution for Future Communication

 <p><b>LoRaWAN</b></p>	 <p><b>VPN</b></p>	 <p><b>Dual WAN</b></p>
 <p><b>Redundant Power</b></p>	 <p><b>Wide Temperature</b></p>	 <p><b>ESG Energy Monitoring</b></p>

## ESG Energy Monitoring Solution

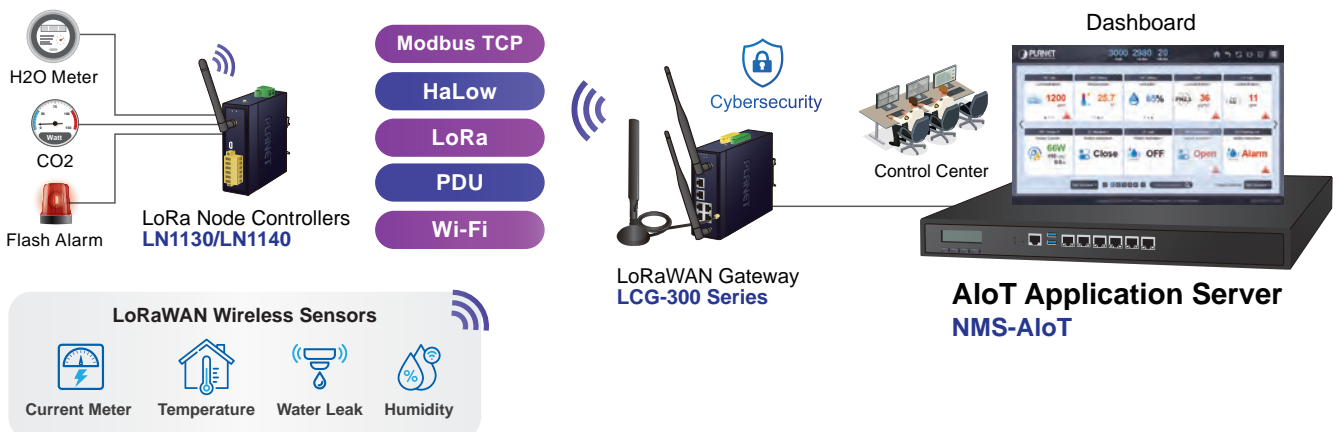

# Comprehensive AIoT Solution

## Utilizing LoRa Technology to Create Efficient AIoT Solution

PLANET AIoT Solution consists of LCG-300 LoRaWAN Gateway Series (LCG-300/LCG-300W/LCG-300NR), AIoT Application Server (NMS-AIoT), LoRa Node Controllers (LN1130/LN1140) and LoRa Sensors (LS Series) which incorporate LoRa technology to bridge LoRa wireless network to an IP network. The LoRa wireless allows users to send data over extremely long ranges with low power consumption. It also offers long-range spread spectrum communication and high interference immunity. PLANET AIoT Solution can help you to promote the implementation of AIoT network.

## AIoT Application Server

### NMS-AIoT

- A unified platform integrating LoRa, Wi-Fi, HaLow, Modbus and more
- ESG energy management reporting with real-time sensor data analysis and carbon footprint reduction
- Support integration with versatile IoT devices
- Intuitive smart dashboard
- Real-time environmental monitoring and analysis
- Precise device location mapping
- 24/7 real-time event notifications
- Early error detection and anomaly resolution
- Support for future software upgrades
- Support for private and PLANET cloud platforms



## Industrial LoRaWAN Gateway for 300 Nodes

### LCG-300-NR

- 8 programmable parallel demodulation paths
- Supports Frequency Band EU868/US915/AS923 MHz Sub 1G
- Web UI for LoRa and network configuration
- SSL VPN and robust hybrid VPN (IPSec/PPTP/L2TP over IPSec)
- DC 9 to 54V redundant power; -40 to 75 degrees C operating temperature
- IP30 metal case with DIN-rail or wall-mount design
- Global 5G NR (NSA/SA) / 4G LTE network for cellular network connection



### LCG-300/LCG-300W

- 8 programmable parallel demodulation paths
- Supports Frequency Band EU868/US915/AS923 MHz Sub 1G
- Web UI for LoRa and network configuration
- Concurrent dual-band connectivity in 2.4GHz (600Mbps) and 5GHz (1200Mbps)(LCG-300W)
- SSL VPN and robust hybrid VPN (IPSec/PPTP/L2TP over IPSec)
- DC 9 to 54V redundant power; -40 to 75 degrees C operating temperature
- IP30 metal case with DIN-rail or wall-mount design



### LCG-350W-NR

- 8 programmable parallel demodulation paths
- Supports Frequency Band EU868/US915/AS923 MHz Sub 1G
- Web UI for LoRa and network configuration
- SSL VPN and robust hybrid VPN (IPSec/PPTP/L2TP over IPSec)
- AC 100 to 277V and/or PoE Power Supply
- IP67 rating waterproof
- -40 to 75 degrees C operating temperature
- Support 5G NR (NSA/SA) / 4G LTE network for cellular network connection



# LoRa Node Controller

## LN1130

- Ultra-wide-distance transmission up to 10km with line of sight
- Easy to connect with multiple wired sensors through RS232/RS485 interface
- Triggers multiple conditions and actions
- Compliant with standard LoRaWAN gateways and network servers
- 9 to 48V DC power with reverse polarity protection (AC 24V power adapter acceptable)
- Industrial metal case IP30 design with wide -40 ~ 75°C operating temperature range



## LN1140

- Ultra-wide-distance transmission up to 10km with line of sight
- 2DI/DO interfaces each for operating application
- Triggers multiple conditions and actions
- Compliant with standard LoRaWAN gateways and network servers
- 9 to 48V DC power with reverse polarity protection (AC 24V power adapter acceptable)
- Industrial metal case IP30 design with wide -40 ~ 75°C operating temperature range



## LN502

- Ultra-wide-distance transmission up to 10km with line of sight
- Easy to connect with multiple wired sensors through RS485 / RS232
- Two DI and DO interfaces
- 3.3V/5V DC Output for Emergency Power Use
- Triggers multiple conditions and actions
- Compliant with standard LoRaWAN gateways and network servers
- Sustainably powered by a solar-charged battery for continuous operation or 9 to 48 DC power supply.
- IP67 rating
- Supports Frequency Band EU868/US915/AS923 MHz Sub 1G



# LoRa Sensor

LoRa sensor devices serve a myriad of purposes, including flood detection, temperature and humidity monitoring, PIR motion sensing, and more. Leveraging the LoRaWAN protocol, these devices ensure long-range wireless communication in IoT applications. Their notable benefits include extended battery life due to low power consumption. Widely applied in scenarios such as smart agriculture, industrial monitoring, and asset tracking, LoRa sensors offer a cost-effective and reliable solution for collecting and transmitting data over considerable distances, making them invaluable in diverse environmental and operational contexts.

## LS100 series



### LS100-WL

- Water Leak Sensor
- IP65 rating
- LoRaWAN™ Class A compatible



### LS100-PIR

- Indoor Occupancy Sensor (Occupancy/ Light/Temperature)
- IP30 rating
- LoRaWAN™ Class A compatible



### LS100-DW

- Door and Window Contact Sensor
- IP30 rating
- LoRaWAN™ Class A compatible



### LS100-CO/LS100-SMK

- CO Sensor/Smoke Detector
- IP20 rating
- LoRaWAN™ Class A compatible

## LS200 series



### LS200-TH

- Indoor Temperature and Humidity Sensor (-20~55 degrees C)
- IP65 rating
- LoRaWAN™ Class A compatible



### LS200-PT

- Machine Temperature Sensor with Thermocouple (-70~200 degrees C)
- IP65 rating
- LoRaWAN™ Class A compatible



### LS200-TC

- Machine Temperature Sensor with Thermocouple (-40~125 degrees C)
- IP65 rating
- LoRaWAN™ Class A compatible



### LS200-RF

- Refrigerator Temperature and Humidity Sensor (-40~55 degrees C)
- IP65 rating
- LoRaWAN™ Class A compatible



### LS200-CM3

- 3-phase Current Meter with Clamp-On CT
- Measure 75A current maximum
- IP53 rating
- LoRaWAN™ Class A compatible



### LS200-LG

- Light Level Sensor
- IP65 rating
- LoRaWAN™ Class A compatible



### LS200-VOC

- TVOC Sensor
- IP65 rating
- LoRaWAN™ Class A compatible



### LS200-PM25

- PM2.5 Sensor
- IP30 rating
- LoRaWAN™ Class A compatible



### LS200-MF8

- Temperature/Humidity/PIR/Tilt/Vibration/ Reed Switch/Light/Glass Break Sensor
- IP30 rating
- LoRaWAN™ Class A compatible



### LS250-PLUG

- Light Level Sensor
- IP20 rating
- LoRaWAN™ Class C compatible

# Comprehensive Intelligent 802.3bt PoE++ Solution for High-Power Networking



Touch Color LCD



2.5G/10Gbps PoE



Intelligent PoE Management



10G Uplink

## Unique Intelligent PoE Management for Power Savings



Real-time PoE Status



PoE Schedule



PD Alive Check Remote and Surveillance



# Power over Ethernet

## Enhanced Power Budget

PLANET PoE Solution provides full power budget to satisfy the increasing needs for power consumption of powered devices, such as wireless APs, IP phones, and IP cameras. Their IP-based, remote Web management interfaces also provide an effective central power management solution to monitor and control per port power feeding of deployed powered devices. PLANET PoE Solution with high power capability helps realize commercial-grade and industrial-grade network applications.



## Intuitive PoE Management via Touch LCD

PLANET has developed the world's first PoE Managed Switch series with intuitive color touch LCD interface to allow the network management in real time without logging in to the computer, greatly enhancing the management efficiency. The network system, PoE PDs, and even the cable diagnostics can be easily managed through this cutting-edge user-friendly touch LCD panel built in the PoE Switches. Moreover, the Color Touch LCD PoE Switch supplies 10G data transmission capability, high power PoE from IEEE 802.3af/at 30-watt to 60~95-watt ultra power, intelligent PoE functions, and unique ONVIF support to promote the network performance for SMEs, enterprises, public places and industrial hardened environments.



## Uniquely Intelligent PoE Management for Power Saving

In order to support users to conveniently manage the PoE system or end-span devices in the client site, PLANET has developed a unique and user-friendly Intelligent PoE Management function which effectively assists the IT managers in improving the efficiency of management, saving the cost of maintenance, and extending the life of products.



The **PoE Intelligent Temperature Detection and Control function** automatically detects the temperature of the environment and operating product. If the operating product is over normal temperature, this function will be enabled automatically to prevent the product from damage.



The **PoE Power Detection function** improves the working efficiency of IT manager. IT manager can check the total power consumption of all connected devices and power consumption of each connected device. In order to prevent connected devices from damage, this function is automatically enabled.

## Extending IP Network Transmission

For long-distance IP network transmission, PLANET network devices are integrated with wireless and wired technologies, such as Ethernet, fiber and coaxial cables, and Power over Ethernet.

# Intelligent PoE Management Functions



## Intelligent Powered Device Alive Check

PLANET PoE switches can be configured to monitor connected PD (Powered Device) status in real time via ping action. It will greatly enhance the network reliability through the PoE port resetting the PD's power source and reducing administrator management burden.

### PoE PD Alive Check

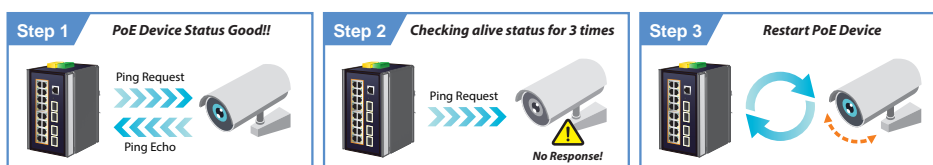

## PoE Schedule for Energy Saving

The "PoE schedule" function helps you to enable or disable PoE power feeding for each PoE port during specified time intervals and it is a powerful function to help SMBs or enterprises save power and money.

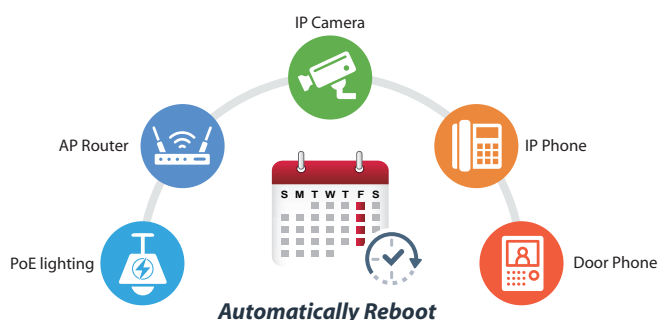
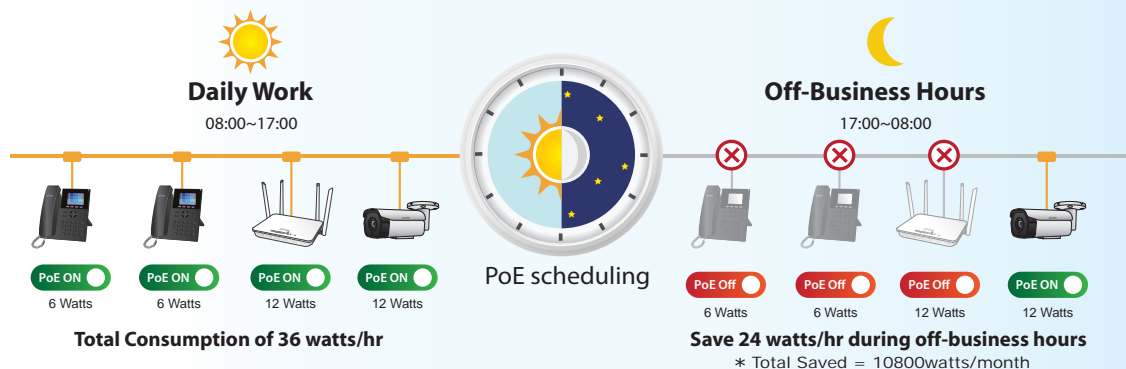

## Scheduled Power Recycling

PLANET PoE switches allow each of the connected PoE IP cameras or PoE wireless access points to reboot at a specific time each week. Therefore, it will reduce the chance of IP camera or AP crash resulting from buffer overflow.

## PoE Priority for Critical Service

The PoE power budget can be allocated by priorities or classification and sent alert event logs when power usage reaches the defined threshold.

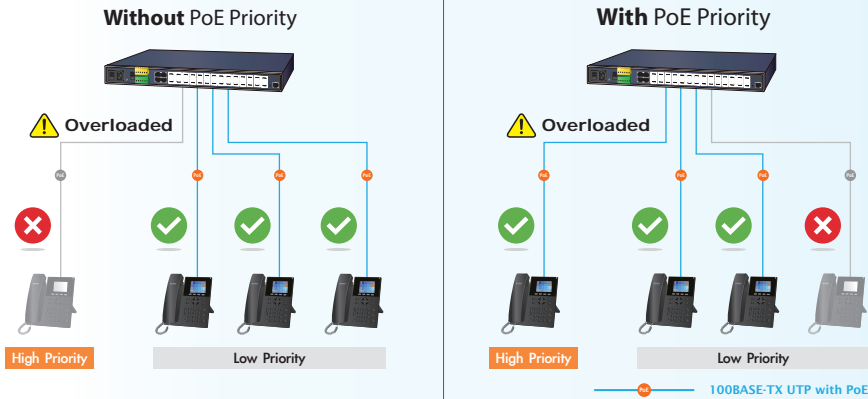

## PoE Over Temperature Protection

The automatic Over Temperature Protection helps to prevent power budget overloading while the temperature rises.

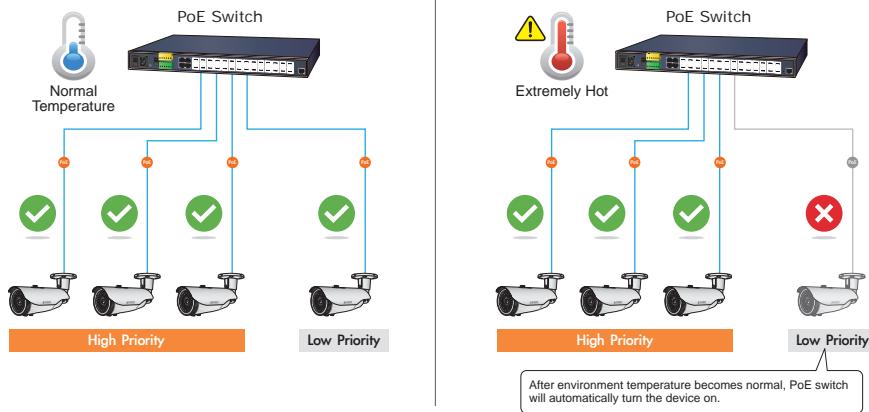

## PoE Usage Monitoring

Via the power usage chart in the web management interface, PLANET PoE switches enable the administrator to monitor the status of the power usage of the connected PDs in real time.

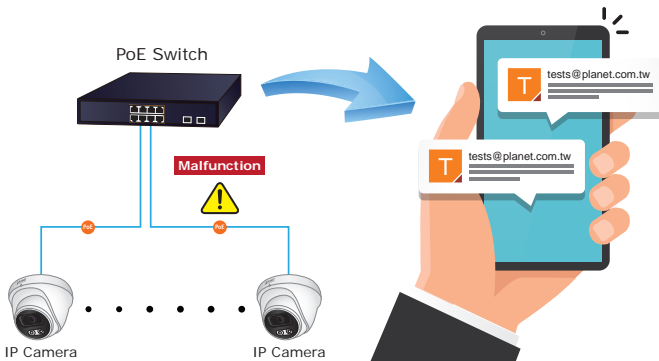

## SMTP/SNMP Trap Event Alert

Though most NVR or camera management software offers SMTP email alert function, PLANET PoE Switches further provide event alert function to help to diagnose the abnormal device owing to whether or not there is a break of the network connection, loss of PoE power or the rebooting response by PD Alive Check process.

# Layer 3 802.3at PoE+ Stackable Managed Switch



PLANET SGS PoE Series is a Layer 3 PoE Stackable Managed Gigabit Switch that provides high density performance, Layer 3 static routing, RIP (Routing Information Protocol) and OSPF (Open Shortest Path First). With the built-in SFP+ slots performing up to 216Gbps switching fabric, the SGS PoE Series can handle extremely large amounts of data in a secure topology linking to an enterprise backbone or high capacity servers. The powerful WRR (Weighted Round Robin) and Network Security features make the SGS PoE Series perform effective data traffic control for ISP and enterprise VoIP, video streaming, and multicast applications. The SGS PoE Series has 24/48 IEEE 802.3at PoE+ ports and PoE budget up to 370/740 (AC+DC) watts for catering to medium-and large-scale VoIP or IP surveillance networks at a lower total cost.

- Complies with IEEE 802.3at Power over Ethernet Plus, end-span PSE
- Supports PoE power up to 30 watts for each PoE port
- Remote PoE Power management and monitoring
- IP routing protocol: IPv4/IPv6 Layer 3 Static Routing, RIP and OSPF
- Single IP address management, supporting up to 24 units stacked together (SGS-6341-24P4X)
- IEEE 802.1Q VLAN, Private VLAN, Q-in-Q and Voice VLAN
- Layer 2, 3 and 4 Access Control List
- Quality of Service (QoS)
- IEEE 802.1D/1w/1s Spanning Tree Protocol
- IGMP Snooping v1, v2 and v3, and querier mode
- Management interface – console; telnet; IPv6 and IPv4 Web; SNMP v1, v2c and v3; SSL and SSH

## SGS-6341-24P4X

- 10/100/1000BASE-T with 802.3at PoE+ port x 24
- 10GBASE-X SFP+ port x 4
- 370-watt PoE budget

## SGS-6310-24P4X

- 10/100/1000BASE-T with 802.3at PoE+ port x 24
- 10GBASE-X SFP+ port x 4
- 370-watt PoE budget

## SGS-6310-48P6XR

- 10/100/1000BASE-T with 802.3at PoE+ port x 48
- 10GBASE-X SFP+ port x 6
- 370 /740 -watt PoE budget
- 100~240V AC and 55V DC dual power input for maximum PoE budget

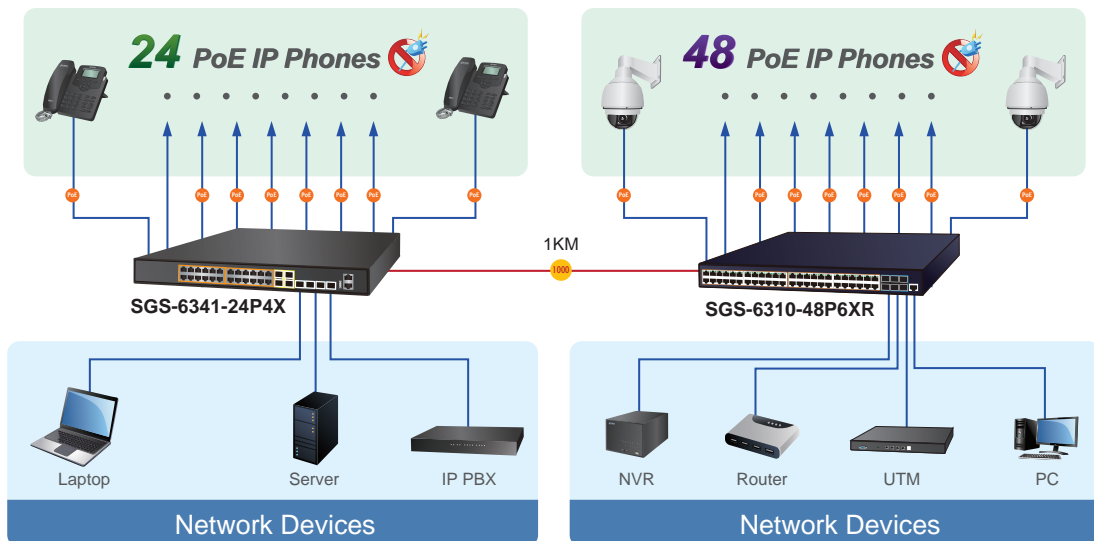

- 1000BASE-T UTP
- PoE 1000BASE-T UTP with PoE
- PoE 1000BASE-SX/LX Fiber-optic

# Touch LCD 10G Layer 3 802.3at/bt PoE Managed Gigabit Switches



## Intuitive LCD for Efficient Management

PLANET GS-6320-24UP2T2XV Smart LCD Layer 3 802.3at/bt PoE Managed Gigabit Switches provide an intuitive touch panel on their front panels that facilitate the Ethernet management and PoE PD management.

- IP address, VLAN and QoS configuration
- PoE management and status
- Port management and status/SFP information
- Troubleshooting: cable diagnostic and remote IP ping
- Maintenance: reboot, factory default and save configuration

The GS-6320-24UP2T2XV LCD PoE switch models featuring PLANET intelligent PoE management to improve the availability of critical business applications have an awesome feature -- ONVIF Support -- which is specifically designed for co-operating with Video IP Surveillances. From the GUI, you just need one click to search and show all of the ONVIF devices via network application, thus enabling to pinpoint the location of the particular surveillance device for easier inspection and planning.

### GS-6320-24UP2T2XV

- 10/100/1000BASE-T with 802.3bt PoE++ port x 24
- 10GBASE-T copper port x 2
- 1G/2.5G/10GBASE-X SFP+ port x 2
- 600-watt PoE budget
- Supports 100~240V AC/48~60V DC redundant power

95W

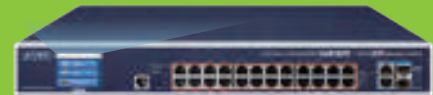
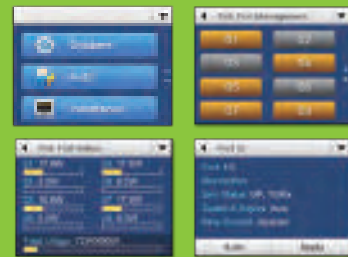

# Extractive Power Supply Design to Increase Flexibility



## Extractive Power Supply Design to Increase Flexibility

The GS-6322-24P4X is designed with two extractive power module slots to support Redundant Power Supply (RPS) mode or Extended Power Supply (EPS) mode via software setting to handle the demands of power redundancy or additional power for PoE++ ports as needed.

- RPS (1+1) mode: Where critical services are supported by PoE application, the secondary PSU is needed to provide backup power in the event of a power outage. When two PSUs are installed, the power budget is the same as that of one PSU.
- EPS (2+0) mode: Where more PoE budget is required to support complete application, the secondary PSU can provide additional PoE power. The two PSUs combined are able to provide a maximum of total PoE power.

The GS-6322-24P4X can work with three optional 920W/1200W/2000W AC power supplies. Its flexible redundant and extended power system is specifically designed for high-tech facilities requiring the highest power integrity.

### GS-6322-24P4X

- 10/100/1000BASE-T with 802.3bt PoE++ port x 24
- 10GBASE-T copper port x 2
- 1G/2.5G/10GBASE-X SFP+ port x 2
- Dual power module slots
- EPS(2+0)/RPS(1+1) power management
- Up to 2,280-watt PoE budget



Dual Replaceable Power Module

# 10G L3 802.3bt PoE++ Managed Gigabit Switches



## All-Port 10G L3 Managed Switch with an Exceptional 95W PoE++ Capability

PLANET XGS-6320-8UP4X Layer 3 10Gbps Ethernet PoE++ Switch is designed for high-bandwidth, power-intensive devices such as Wi-Fi 7/6E access points, thin clients, and AI-based surveillance systems that utilize uncompressed video. It provides versatile connectivity options with 10GBASE-T and 10GBASE-X SFP+ ports, enhancing network reach.

Each port supports up to 95W of PoE power, meeting IEEE 802.3bt Type 4 standards and providing a total 420W PoE budget. Featuring advanced data throughput, hardware-based Layer 3 routing, and efficient Layer 2 and Layer 4 switching, it integrates PLANET's (UNI-NMS) and CloudViewerPro app, simplifying IPv6/IPv4 management for seamless control.

- All copper and SFP+ ports deliver pro-level 10Gbps speed for robust connectivity
- Supports PoE Power up to 95 watts for each PoE Port
- Implements ITU-T G.8032 Ethernet Ring Protection Switch (ERPS) for seamless network resilience
- Enhances cybersecurity with SSHv2, TLSv1.2 and SNMPv3, ensuring robust protection against cyber threats
- Cutting-edge support for 1588v2 PTP protocol transparent clock, ensuring precise network synchronization

### XGS-6320-8UP4X

- 10GBASE-T 802.3bt PoE++ port x 8
- 10G/2.5G/1GBASE-X SFP+ port x 2
- 400-watt PoE budget
- Up to 95 watts per PoE ++ port

### GS-6311-24HP4X

- 10/100/1000BASE-T 802.3bt PoE++ port x 8
- 10/100/1000BASE-T 802.3at PoE++ port x 16
- 10G/1GBASE-X SFP+ port x 4
- 480-watt PoE budget
- Up to 95 watts per PoE ++ port

### GS-5220-8UP2T2X

- 10/100/1000BASE-T with 802.3bt PoE++ port x 8
- 10/100/1000BASE-T port x 2
- 1G/10G SFP+ port x 2
- 240-watt PoE budget
- Up to 95 watts per PoE port
- 13-inch desktop size

# 10G L3 802.3at/802.3bt Managed Multigigabit Switches



The MGS-6311-8P2X is PLANET's first Multigigabit Layer 3 Managed Switch designed in compact size. Offering 8-port PoE 2.5GBASE-T and 2-port dual speed 10G SFP+, it breaks the bandwidth limitation of connecting the wireless network with the wired network. Featuring L3 routing and PLANET Intelligent PoE functions, it provides a highly-secure, environment-friendly network management and accelerates the deployment of wireless network infrastructure for smart cities.

### MGS-6320-8HP2X

- 2500/1000/100BASE-T 802.3bt PoE++ port x 4
- 10/100/1000BASE-T 802.3at PoE+ port x 4
- 1G/2.5G/10G SFP+ port x 2
- 240-watt PoE budget
- Up to 95 watts per PoE++ port

### MGS-6311-8P2X

- 2500/1000/100BASE-T 802.3at PoE+ port x 8
- 10G/1GBASE-X SFP+ port x 2
- 240-watt PoE budget
- Up to 95 watts per PoE ++ port

# 10G L3 802.3at PoE+ Managed Gigabit Switches



## IPv6 Routing and 10G Ethernet Switch Solutions with PoE Plus for SMBs

PLANET GS-6311 and GS-6320 Layer 3 Managed PoE Switch series supports both IPv4 and IPv6 protocols, and hardware-based Layer 3 static routing capability. They comply with IEEE 802.3at Power over Ethernet Plus (PoE+), equipped with 8 to 48 10/100/1000BASE-T Gigabit Ethernet ports and 2 or 4 10G SFP+ uplink slots. All their Gigabit Ethernet ports when integrated with an 802.3at PoE+ injector can be in full operation.

## Extended 10G Network Infrastructure Solution

With the 2/4 built-in SFP+ slots, the GS-6311/GS-6320 series performs up to 176Gbps non-blocking switch fabric to handle extremely large amounts of data. It greatly helps SMBs to build 10Gbps Ethernet network, fulfilling the need of backbone connection, heavy transmission of video streaming services, cloud services and NAS applications at an affordable price.

### GS-6311-48P6X

- 10/100/1000BASE-T 802.3at PoE++ port x 48
- 10G/1GBASE-X SFP+ port x 6
- 480-watt PoE budget
- Up to 32 watts per PoE ++ port

### GS-6311-24HP4X

- 10/100/1000BASE-T 802.3bt PoE++ port x 8
- 10/100/1000BASE-T 802.3at PoE++ port x 16
- 10G/1GBASE-X SFP+ port x 4
- 480-watt PoE budget
- Up to 95 watts per PoE ++ port

### GS-6311-24P4XV

- 10/100/1000BASE-T with 802.3at PoE+ port x 24
- 10GBASE-X SFP+ slot x 4
- 370-watt PoE budget
- 2-inch Smart Color LCD for easy management and monitoring

### GS-6320-8P2X

- 10/100/1000BASE-T with 802.3at PoE+ port x 8
- 10G SFP+ port x 2
- 120-watt PoE budget
- Up to 36 watts per PoE port
- 13-inch desktop size

# L2+ 802.3at PoE+ Managed Gigabit Switches



To meet the PoE network applications requiring higher power supply with Gigabit speed transmission, PLANET L2+ 802.3at PoE+ Managed Switches provide user-friendly but advanced IPv6 and IPv4 management interfaces to bring out efficiently centralized High Power PoE management. It offers IPv4 and IPv6 VLAN routing feature which allows to crossover different VLANs and different IP addresses for the purpose of having a highly-secure, flexible management and simpler networking applications.

As an advanced PoE switch designed for non-stop surveillance or wireless networks, the L2+ Managed PoE switches feature intelligent PoE functions such as PD alive check, scheduled power recycling and over-temperature protection to improve the availability of critical business applications. Time-based PoE schedule can be used to control PoE power feeding during specified time intervals to help companies and campuses to save power and money.

### GS-5220-8P2T2S

- 10/100/1000BASE-T with 802.3at PoE+ port x 8
- 10/100/1000BASE-T port x 2
- 100/1000BASE-X SFP port x 2
- 240-watt PoE budget
- 13-inch desktop size, 1U rack-mountable
- Smart fan design for silent operation

### WGSW-24040HP4

- 10/100/1000BASE-T with 802.3at PoE+ port x 24
- 100/1000BASE-X SFP port x 4
- 440-watt PoE budget

# L2/L4 802.3at/bt PoE Managed Gigabit Switches



The L2/L4 802.3at/bt PoE Managed Gigabit Switches allow users to flexibly connect standard and high powered devices simultaneously. To facilitate power management, the Switches come with powerful PoE management features such as over temperature protection, usage threshold alert and auto power allocation to prevent power budget overloading. The PoE power budget can be allocated by priorities or classification and send alert event logs when power usage reaches the defined threshold.

- Complies with IEEE 802.3at/bt Power over Ethernet end-span PSE
- Supports PoE power up to 30.8/60 watts for each PoE port
- Remote PoE power management and monitoring
- Supports PD alive check, scheduled power recycling and time-based PoE schedule and over temperature protection
- IEEE 802.1Q VLAN, Private VLAN and Q-in-Q
- Layer 3 and 4 Access Control List
- Quality of Service (QoS)
- IEEE 802.1D/1w Spanning Tree Protocol
- IGMP snooping v1 and v2, MLD snooping
- Management interface – console ; Telnet Web; SNMP v1, v2c and v3; SSL and SSH

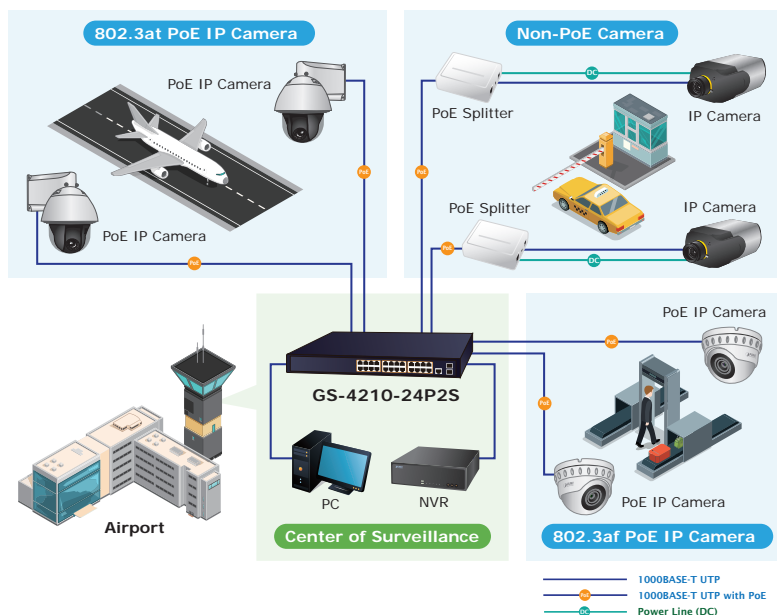

## GS-4210-8P2S/GS-4210-8P2C

- 10/100/1000BASE-T with 802.3at PoE+ port x 8
- 100/1000BASE-X SFP port x 2
- 120-watt PoE budget
- 12-inch desktop size, 1U rack-mountable
- Smart fan design for silent operation

## GS-4210-8UP2S

- 10/100/1000BASE-T with 802.3bt PoE++ port x 8
- 100/1000BASE-X SFP port x 2
- 180-watt PoE budget
- 12-inch desktop size, 1U rack-mountable
- Smart fan design for silent operation

## GS-4210-16P4C/GS-4210-16P2S

- 10/100/1000BASE-T with 802.3at PoE+ port x 16
- 10/100/1000BASE-T port x 4
- 100/1000BASE-X SFP port x 2/4
- 240-/220-watt PoE budget

## GS-4210-24P2S

- 10/100/1000BASE-T with 802.3at PoE+ port x 24
- 100/1000BASE-X SFP port x 2
- 300-watt PoE budget

## GS-4210-24P4C/GS-4210-24PL4C

- 10/100/1000BASE-T with 802.3at PoE+ port x 24
- 10/100/1000BASE-T port x 4
- 100/1000BASE-X SFP port x 4
- 280-/430-watt PoE budget
- Smart fan design for silent operation

## GS-4210-48P4S

- 10/100/1000BASE-T with 802.3at PoE+ port x 48
- 100/1000BASE-X SFP port x 4
- 600-watt PoE budget
- Smart fan design for silent operation

## GS-4210-16UP4C

- 10/100/1000BASE-T with 802.3bt PoE++ port x 16
- 10/100/1000BASE-T port x 4
- 100/1000BASE-X SFP port x 4
- Up to 95 watts of PoE power on 4-pair UTP
- 400-watt PoE budget

95W

## GS-4210-16UP8T4X/GS-4210-24UP4X

- 10/100/1000BASE-T port x 8 (GS-4210-16UP8T4X)
- 10/100/1000BASE-T with 802.3bt PoE++ port x 16/24
- 10GBASE-X SFP+ slot x 4
- Up to 95 watts of PoE power on 4-pair UTP
- 420/720-watt PoE budget

95W



## L2/L4 802.3af PoE+ Managed Switches



PLANET L2/L4 Managed 802.3af/at PoE switches provide a cost-effectiveness advantage to local area network and are widely accepted in SMB office network. They provide intelligent Layer 2 data packet switching and management functions, friendly web user interface, and stable operation. They also comply with Power over Ethernet (PoE) at an affordable price. The Managed PoE switches feature 8-port PoE to 24-port PoE choices to meet various customer requirements. They offer a rack-mountable, safe and reliable power solution for SMBs deploying PoE VoIP systems and PoE wireless networks, or requiring enhanced data security and network traffic management.

### FGSD-1008HPS

- 10/100BASE-TX with 802.3af PoE+ port x 8
- 10/100/1000BASE-T port x 2
- 1000BASE-X SFP port x 2
- 120-watt PoE budget
- 12-inch desktop size, 1U rack-mountable

### FGSW-1816HPS

- 10/100BASE-TX with 802.3af PoE+ port x 16
- 10/100/1000BASE-T port x 2
- 1000BASE-X SFP port x 2
- 240-watt PoE budget
- 19-inch, 1U rack-mountable

### FGSW-2624HPS/FGSW-2624HPS4

- 10/100BASE-TX with 802.3af PoE+ port x 24
- 10/100/1000BASE-T port x 2
- 1000BASE-X SFP port x 2
- 240-/370-watt PoE budget
- 19-inch, 1U rack-mountable

## Web Smart Ethernet Switch



### Efficient Network Management Through NMS and App

The GS-2210 Web Smart Switch series, known for such features as QoS, Link aggregation, VLANs, IGMP, and so on, provides an eye-catching feature called NMS developed by PLANET to easily and remotely manage and monitor network devices in the local environment from mobile app. This feature not only improves operational convenience, but also ensures users to have real-time control over their network infrastructure. It provides users with an unparalleled experience.

- PLANET NMS and NMSViewerPro for deployment management
- 8 to 24 IEEE 802.3af PoE ports with a total PoE budget of up to 260 watts
- Supports PoE schedule, PD alive check and ONVIF
- Supports static trunk, QoS, port isolation and cable diagnostics
- IPv4 IGMP snooping v1, v2; DHCP snooping and IEEE 802.1Q VLAN

### GS-2210-8P2S/GS-2210-16P2S/ GS-2210-24P2S

- 10/100/1000BASE-T with 802.3af PoE+ ports x 8/16/24
- 100/1000BASE-X SFP ports x 2
- 120/240/260-watts PoE budget

# Unmanaged LCD PoE+ Switches



PLANET LCD PoE Switches are an ideal Plug and Watch Power over Ethernet solution which provides quick installation, real-time PoE work status monitoring and immediate troubleshooting through its unique LCD display to improve work efficiency and quality without any PC or software required.

The LCD monitors of the LCD PoE Switches clearly show the PoE loading of each port, total PoE power usage and system status, such as overload, low voltage, over voltage and high temperature. With its brand-new LCD monitor, user is able to obtain detailed information about real-time PoE working condition of the LCD PoE Switches directly. Also the Power Budget Control function helps to prevent power budget overloading.

## LCD Monitor Status

**Switch Port Information**

01	30.3W	---	M	867M	08	---	W	---	M	---	M
02	---	---	W	---	M	09	-8.3W	---	M	<	1M
03	---	---	W	---	M	10	---	---	W	---	M
04	15.4W	---	M	---	M	11	-OFF-	---	M	---	M
05	---	---	W	---	M	12	---	---	W	---	M
06	---	---	W	---	M	13	17.6W	223M	246M	---	M
07	---	---	W	---	M	14	---	---	W	---	M

PB: 300W    TP: 72W    PD: 0

**Main Menu**

- 01 - Switch Mode
- 02 - Budget Control
- 03 - PSE Port Priority
- 04 - PSE Port Enable
- 05 - PD Type
- 06 - Alive Check
- 07 - Bandwidth
- 08 - Fan Control

**Switch Mode**

Options:

- Standard <
- VLAN
- Extend

**PSE Port Enable**

Port	Status
01	Enable <
	Disable

Current Setting: Enable

<UP>/<Down>: Select  
<Enter>: Confirm <Back>: Return

### GSD-1222VHP

- 10/100/1000BASE-T with 802.3 at PoE+ port x 8
- 10/100/1000BASE-T uplink port x 2
- 1000BASE-X SFP port x 2
- Hardware DIP Switch, including Standard, VLAN and Extend mode.
- 120-watt PoE budget
- LCD with real-time PoE port status display, and power and alarm alerts
- VLAN Isolation
- 250m distance w/30W power output in Extend Mode
- 12-inch, 1U, rack-mountable

### GSW-1820VHP/GSW-2620VHP

- 10/100/1000BASE-T with 802.3 at PoE+ port x 16/24
- 1000BASE-X SFP uplink port x 2
- Hardware DIP Switch, including Standard, VLAN and Extend mode.
- 300-watt PoE budget
- LCD with real-time PoE port status display, and power and alarm alerts
- VLAN Isolation
- 250m distance with 30W power output in Extend Mode

### FGSD-1022VHP

- 10/100BASE-TX with 802.3 at PoE+ port x 8
- 10/100/1000BASE-T uplink port x 2
- Hardware DIP Switch, including Standard, VLAN and Extend mode.
- 120-watt PoE budget
- LCD with real-time PoE port status display, and power and alarm alerts
- VLAN Isolation
- 250m distance with 30W power output in Extend Mode
- 12-inch, 1U, rack-mountable

### FGSW-1822VHP/FGSW-2622VHP

- 10/100BASE-TX with 802.3at PoE+ port x 16/24
- 10/100/1000BASE-T port x 2
- 1000BASE-X SFP uplink port x 2
- 300-watt PoE budget
- LCD with real-time PoE port status display, and power and alarm alerts
- 250m distance with 30W power output in Extend Mode

# Industrial Flat-type PoE+ Switches

## Easily-deployed and Expanded PoE Network

Designed to be installed in a wall enclosure or simply mounted at any convenient location on a wall, PLANET Industrial Flat-type PoE+ Switches are an ideal solution to meeting the demand of sufficient PoE power for the network applications such as building/home automation network, Internet of things (IoT), and wired and wireless IP surveillance.

## Innovative Wall-mount Installation

The Industrial Flat-type PoE+ Switches adopt "Front Access" design, making the installing, cable wiring, LED monitoring and maintenance of the Industrial Flat-type PoE+ Switches placed in an enclosure easier for technicians to manage. Its magnetic wall mounting or DIN rail installation enables its efficient use of enclosure space, thereby making its usability more flexible.

### WGS-6325-8UP2X

- 2500/1000/100BASE-T 802.3bt PoE++ port x 4
- 10/100/1000BASE-T with 802.3bt PoE++ port x 4
- 10G/2.5G/1GBASE-X SFP+ port x 2
- Up to 480-watt PoE budget
- Up to 95 watts per PoE++ port
- IPv4/IPv6 OSPF dynamic routing
- ERPS Ring Data Recovery time < 10ms
- Supports Modbus TCP/IP Protocol
- 48~54V DC dual power design



### WGS-5225-8UP2SV

- 2.4-inch color LCD touch screen
- 10/100/1000BASE-T with 802.3bt PoE++ port x 8
- 100/1000/2500BASE-X SFP port x 2
- Up to 720-watt PoE budget
- Up to 95 watts per PoE port
- ERPS Ring Data Recovery time < 10ms
- Supports Modbus TCP/IP Protocol
- 48~54V DC dual power design



### WGS-5225-8P2S/ WGS-5225-8P2SV

- 2.4-inch color LCD touch screen with management functions (WGS-5225-8P2SV)
- 8-Port 10/100/1000/2500BASE-T RJ45 with 802.3at PoE+
- 2-Port 100/1G/2.5GBASE-X SFP
- PoE budget up to 240W max.
- Dual 48~54V DC redundant power
- ITU G.8032 ERPS ring
- Layer 3 Static route supported
- Modbus TCP/IP protocol supported



### WGS-4215-8P2X/ WGS-4215-8P2XV

- 2.4-inch color LCD touch screen with management functions (WGS-4215-8P2XV)
- 8-Port 10/100/1000/2500BASE-T RJ45 with 802.3at PoE+
- 2-Port 100/1G/2.5G/10GBASE-X SFP+
- PoE budget up to 288W max.
- Dual 48~54V DC redundant power
- ITU G.8032 ERPS ring
- Layer 3 Static route supported



### WGS-4215-8HP2S

- 10/100/1000BASE-T 802.3bt PoE++ port x 8
- 10/100/1000BASE-T 802.3at PoE+ port x 4
- 100/1000BASE-X SFP port x 2
- 360-watt PoE budget
- PD alive check, scheduled power recycling and time-based PoE schedule
- IPv6 and IPv4 Web; Telnet; SNMPv1, v2c, v3; SSH/TLS management



### WGS-4215-16P2S

- 16-port 10/100/1000T with 802.3at PoE+
- 2-port 100/1000X SFP
- -10 to 60 degrees C wide operating temperature
- 48~56V DC dual power input
- 200-watt PoE budget, up to 16 PoE port
- PD alive check, scheduled power recycling and time-based PoE schedule
- IPv6 and IPv4 Web; Telnet; SNMPv1, v2c, v3; SSH/SSL management
- QoS, bandwidth control, storm control, Layer 3/4 access control list
- STP/RSTP/MSTP, LACP



### WGS-4215-8P2S

- 8-port 10/100/1000T with 802.3at PoE+
- 2-port 100/1000X SFP
- -40 to 75 degrees C wide operating temperature
- 48~56V DC dual power input
- 200-watt PoE budget
- IPv6 and IPv4 Web; Telnet; SNMPv1, v2c, v3; SSH/SSL management
- QoS, bandwidth control, storm control, Layer 3/4 access control list
- STP/RSTP/MSTP, LACP



### WGS-804HP

- 4-port 10/100/1000BASE-T with 802.3at PoE+
- 4-port 10/100/1000BASE-T
- -40 to 75 degrees C wide operating temperature
- 48~56V DC redundant power
- IPv6 and IPv4 Web, Telnet and SNMP management
- 802.1Q VLAN, MSTP and IGMP snooping
- LED indicators for PoE usage and status
- 144-watt PoE budget



### WGS-818HP/WGS-814HP/ WGS-804HP

- 8-port 10/100/1000BASE-T with 802.3at PoE+
- 4-port 10/100/1000BASE-T with 802.3at PoE+
- 4-port 10/100/1000BASE-T
- -10 to 60 degrees C operating temperature
- 48~56V DC redundant power
- LED indicators for PoE usage and status
- 120-watt/60-watt PoE budget



# Industrial Flat-type Gigabit PoE+ Routers

## WGR-500-4P

- 4-port 10/100/1000BASE-T with 802.3at PoE+
- 802.1Q VLAN and IGMP proxy
- PoE schedule, scheduled power recycling, PD alive check
- IPv6 support for IoT Networking
- Secure firewall protection
- VLAN support for isolated traffic and security



# Unmanaged PoE+/PoE++ Switches

## GSD-1022UP

- 10/100/1000BASE-T with 802.3bt PoE++ port x 2 and 802.3at PoE port x 4
- 10/100/1000BASE-T port x 2
- 120-watt PoE budget
- 802.3bt PoE++/Legacy via DIP selection
- Compact size, wall-mountable



## GSD-604HP

- 10/100/1000BASE-T with 802.3at PoE+ port x 4
- 10/100/1000BASE-T port x 2
- 55-watt PoE budget
- Port-based VLAN via DIP selection
- Compact size, wall-mountable



## GSD-908HP

- 10/100/1000BASE-T with 802.3at PoE+ port x 8
- 10/100/1000BASE-T port x 1
- 100-watt PoE budget
- Compact size, wall-mount and magnetic wall mountable



## GSD-1008HP

- 10/100/1000BASE-T with 802.3at PoE+ port x 8
- 10/100/1000BASE-T port x 2
- Hardware-based DIP switch for Standard, VLAN and Extend mode selection
- 120-watt PoE budget
- 9-inch, 1U rack-mountable



## MGS-910XP

- 10/100/1000/2500BASE-T 802.3at PoE+ port x 8
- 10G SFP+ port x 1
- 120-watt PoE budget
- Desktop size, 1U rack-mountable



## GSD-2022P

- 10/100/1000BASE-T with 802.3at PoE+ port x 16
- 10/100/1000BASE-T port x 2
- 1000BASE-X SFP port x 2
- 185-watt PoE budget
- Hardware-based DIP switch for Standard, VLAN and Extend mode selection
- Desktop size, 1U rack-mountable



## GSW-1820HP

- 10/100/1000BASE-T with 802.3at PoE+ port x 16
- 1000BASE-X SFP port x 2
- Hardware-based DIP switch for Standard, VLAN and Extend mode selection
- 220-watt PoE Power budget
- 19-inch, 1U rack-mountable



## GSW-2620HP

- 10/100/1000BASE-T with 802.3at PoE+ port x 24
- 1000BASE-X SFP port x 2
- Hardware-based DIP switch for Standard, VLAN and Extend mode selection
- 220-watt PoE Power budget
- 19-inch, 1U rack-mountable



## GSW-2824P

- 10/100/1000BASE-TX 802.3at PoE+ port x 24
- 10/100/1000BASE-T port x 4
- 1000BASE-X SFP port x 2
- 250-watt PoE budget
- Hardware-based DIP switch for Standard, VLAN and Extend mode selection
- 19-inch, 1U rack-mountable



Gigabit

Fast Ethernet

**FSD-604HP**

- 10/100BASE-TX with 802.3at PoE+ port x 4
- 10/100BASE-TX port x 2
- Extend power + data and port-based VLAN via DIP selection
- 60-watt PoE budget
- Internal AC, fanless design



**FSD-1008HP**

- 10/100BASE-TX with 802.3at PoE+ port 8
- 10/100BASE-TX port x 2
- Hardware-based DIP switch for Standard, VLAN and Extend mode selection
- 120-watt PoE budget
- 9-inch, 1U rack-mountable



**FGSD-1011HP**

- 10/100BASE-TX with 802.3at PoE+ port x 8
- 10/100/1000BASE-T port x 1, 100/1000X SFP port x 1
- Hardware-based DIP switch for Standard, VLAN and Extend mode selection
- 120-watt PoE budget
- 9-inch, 1U rack-mountable



**FGSD-1821P**

- 10/100BASE-TX 802.3at PoE+ port x 16
- 10/100/1000BASE-T port x 2
- 1000BASE-X SFP port x 1
- 185-watt PoE budget
- Hardware-based DIP switch for Standard, VLAN and Extend mode selection
- Desktop size, 1U rack-mountable



**FGSD-2621P**

- 10/100BASE-TX 802.3at PoE+ port x 24
- 10/100/1000BASE-T port x 2
- 1000BASE-X SFP port x 1
- 185-watt PoE budget
- Hardware-based DIP switch for Standard, VLAN and Extend mode selection
- Desktop size, 1U rack-mountable



**FGSW-2511P**

- 10/100BASE-TX with 802.3at PoE+ port x 24
- 10/100/1000BASE-T port x 1, 1000X SFP port x 1
- Hardware-based DIP switch for VLAN, QoS and Extend mode selection
- 190-watt PoE budget



**Multi-port PoE Injector Hubs**

**Quick and Easy PoE Network Deployment**

PLANET PoE Injector Hubs provide 4-/12-/24-port IEEE 802.3at/bt Power over Ethernet injector functions and comply with IEEE 802.3, IEEE 802.3u, IEEE 802.3at and IEEE 802.3bt standards. This series supports PoE power for any remote IEEE 802.3at/bt powered device (PD) like wireless access point, IP phone, and IP camera.

**Easy Cabling Installation**

The PoE Injector Hubs are installed between a regular Ethernet Switch and PDs; they inject power to the PDs without affecting the data transmission performance. They offer a cost effective and quick solution to upgrading network system to IEEE 802.3at/bt Power over Ethernet system without replacing the existing Ethernet Switch.

- Complies with IEEE 802.3at/bt Power over Ethernet mid-span PSE
- PoE power up to 95-watt for PoE output
- Remote power feeding up to 100m
- Full power support for each PoE port
- Automatically detects the powered device (PD)
- Indication of LED indicator power input
- 100~240VAC, 50/60Hz, universal power supply

**802.3bt PoE++ Injector Hubs**

**UPOE-800G**

- 10/100/1000BASE-T "Data" input port x 8
- 10/100/1000BASE-T "Data + Power" output port x 8
- 400-watt PoE budget
- PoE Power up to 95 watts for each PoE port
- Web management interface
- SNMP Trap and PoE schedule
- 19-inch, 1U rack-mountable



CloudViewerPro App

**UPOE-1600G**

- 10/100/1000BASE-T "Data" input port x 16
- 10/100/1000BASE-T "Data + Power" output port x 16
- 600-watt PoE budget
- PoE Power up to 95 watts for port 1 to port 8
- PoE Power up to 60 watts for port 9 to port 16
- Web management interface
- SNMP Trap and PoE schedule
- 19-inch, 1U rack-mountable



CloudViewerPro App

**UPOE-2400G**

- 10/100/1000BASE-T "Data" input port x 24
- 10/100/1000BASE-T "Data + Power" output port x 24
- 800-watt PoE budget
- PoE Power up to 95 watts for port 1 to port 8
- PoE Power up to 60 watts for port 9 to port 24
- Web management interface
- SNMP Trap and PoE schedule
- 19-inch, 1U rack-mountable



CloudViewerPro App

## 802.3bt PoE++ Injector Hubs

### UPOE-400

- 100/1G/2.5G/5GBASE-T "Data" input port x 4
- 100/1G/2.5G/5GBASE-T "Data + Power" output port x 4
- 160-watt PoE budget
- Hardware-based DIP switch for 802.3bt PoE+, PoH and Force mode selection
- Compact size, wall-mountable



### IPOE-270/IPOE-270-12V

- 10/100/1G/2.5G/5GBASE-T "Data" input port x 2
- 10/100/1G/2.5G/5GBASE-T "Data + Power" output port x 2
- Up to 90-watt of PoE power on 4-apir UTP
- 180-watt PoE budget
- -40~75 degrees C wide operating temperature
- IP30 metal case, DIN-rail and wall-mountable



### IPOE-470/IPOE-470-12V

- 10/100/1G/2.5G BASE-T "Data" input port x 4
- 10/100/1G/2.5G BASE-T "Data + Power" output port x 4
- Up to 95-watt of PoE power on 4-apir UTP
- 240-watt PoE budget
- -40~75 degrees C wide operating temperature
- IP30 metal case, DIN-rail and wall-mountable



## 802.3at PoE+ Injector Hubs

### HPOE-460

- 10/100/1000BASE-T "Data" input port x 4
- 10/100/1000BASE-T "Data + Power" output port x 4
- 120-watt PoE budget
- PoE Power up to 30.8 watts for each PoE port
- Compact size, wall-mountable



### POE-1200G

- 10/100/1000BASE-T "Data" input port x 12
- 10/100/1000BASE-T "Data + Power" output port x 12
- 220-watt PoE budget
- PoE Power up to 30.8 watts for each PoE port
- Web management interface
- SNMP Trap and PoE schedule
- 19-inch, 1U rack-mountable



### POE-2400G

- 10/100/1000BASE-T "Data" input port x 24
- 10/100/1000BASE-T "Data + Power" output port x 24
- 440 watt PoE budget
- PoE Power up to 30.8 watts for each PoE port
- Web management interface
- SNMP Trap and PoE schedule
- 19-inch, 1U rack-mountable



### HPOE-1200G

- 10/100/1000BASE-T "Data" input port x 12
- 10/100/1000BASE-T "Data + Power" output port x 12
- 360-watt PoE budget
- PoE Power up to 30.8 watts for each PoE port
- Web management interface
- SNMP Trap and PoE schedule
- 19-inch, 1U rack-mountable



### HPOE-2400G

- 10/100/1000BASE-T "Data" input port x 24
- 10/100/1000BASE-T "Data + Power" output port x 24
- 720-watt PoE budget
- PoE Power up to 30.8 watts for each PoE port
- Web management interface
- SNMP Trap and PoE schedule
- 19-inch, 1U rack-mountable



# Single-port PoE Injectors & Splitters

PLANET Single-port PoE Injectors and Splitters are compliant with IEEE 802.3af/at 30-watt PoE and IEEE 802.3bt Ultra PoE standard to help achieve a more flexible network deployment. The PoE injectors insert power into Ethernet cables and allow the cable between the PoE injector and splitter to transfer data and power simultaneously. The PoE splitter is paired with the injector to turn the non-PoE devices into PoE-ready equipment. The maximum distance between the injector and splitter is 100 meters.

## 802.3bt PoE++ Injectors

### POE/IPOE Series

- Complies with IEEE 802.3bt Power over Ethernet
- Maximum power up to 95 watts
- Auto-detection of IEEE 802.3bt PoE++ PDs from being damaged by incorrect installation

### IPOE-171-60W/IPOE-171-95W

- Up to 95 watts of PoE power on 4-pair UTP
- Data and power over one Ethernet cable up to 100 meters
- Backward compatible with IEEE 802.3at/af PD device
- Supports 10/100/1G/2.5G/5G applications
- -40 to 75 degrees C wide operating temperature
- IP30 metal case, DIN-rail and wall-mountable



### POE-171A-60/POE-171A-95

- Up to 95 watts of PoE power on 4-pair UTP
- Data and power over one Ethernet cable up to 100 meters
- Backward compatible with IEEE 802.3at/af PD device
- Supports 10/100/1G/2.5G/5G applications



### POE-176-95

- 802.3bt PoE++ compliant, up to 95-watt power output
- DIP switch for 802.3bt/Force mode selection
- Supports 10/100/1G/2.5G/5G/10G applications



### POE-172/POE-173

- Up to 60 watts of PoE power on 4-pair UTP
- Data and power over one Ethernet cable up to 100 meters
- Backward compatible with IEEE 802.3at/af PD device
- Supports 10/100/1000BASE-T applications



### POE-175-95

- Up to 95 watts of PoE power on 4-pair UTP
- Data and power over one Ethernet cable up to 100 meters
- Backward compatible with IEEE 802.3at/af PD device
- Supports 10/100/1000BASE-T applications



### IGUP-805AT/IGUP-1205AT/IGUP-2205AT

- 1-/1-/2-port 10/100/1000BASE-T 802.3bt PoE++ type-4 PSE
- 1-/2-/2-port 100/1000BASE-X SFP
- -40 to 75 degrees C wide operating temperature.
- 12-56V DC redundant power
- 90W/90W/180W PoE budget
- DIP switch for 802.3bt/PoH/Force mode control



### IPOE-175

- Up to 60 watts of PoE power on 4-pair UTP
- Data and power over one Ethernet cable up to 100 meters
- IP67 and IK10-rated aluminum case
- -40~75 degrees C wide operating temperature
- 24~56V DC to 55V power boost technology



## Ultra PoE Splitters

### POE-171S/POE-172S

- 10/100/1000BASE-T "Data" output port x 1
- 10/100/1000BASE-T "Data + Power" input port x 1
- Up to 50/60 watt power output
- Supports 12V/19V/24V DC power output by DIP switch



## 802.3bt PoE++ Splitters

### IPOE-176S

- 10G/5G/2.5G/1G/100Mbps "Data" output port x 1
- 10G/5G/2.5G/1G/100Mbps Data + Power" 802.3bt PoE++ input port x 1
- Compliant with IEEE 802.3bt PoE++ PD
- Up to 60 watt power output
- Supports 12V/19V/24V DC power output by DIP switch
- -40 to 75 degrees C wide operating temperature (IPOE-176S)
- IP30 metal case, DIN-rail or wall-mountable (IPOE-176S)



### POE-173S/IPOE-173S

- 10/100/1000BASE-T "Data" output port x 1
- 10/100/1000BASE-T "Data + Power" input port x 1
- Up to 60 watt power output
- Supports 12V/24V DC power output by DIP switch (IPOE-173S)
- -40 to 75 degrees C wide operating temperature (IPOE-173S)
- IP30 metal case, DIN-rail and wall-mountable (IPOE-173S)
- Compliant with IEEE 802.3bt PoE++ PD



### IPOE-175S

- Supports 12V DC, 60-watt power output
- IP67 and IK10-rated aluminum case
- -40~75 degrees C wide operating temperature
- Compliant with IEEE 802.3bt PoE++ PD
- Supports 10/100/1G applications

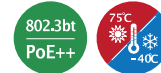

## 802.3at PoE+ Injectors & Splitters

### POE/IPOE/GTP Series

- Complies with IEEE 802.3af/at Power over Ethernet
- Maximum power up to 30.8 watts
- Auto-detection of PoE+ IEEE 802.3at PDs from being damaged by incorrect installation

### GTP-805A

- 10/100/1000BASE-T "Data + Power" output port x 1
- 1000BASE-X "Data" input port x 1
- Mid-span PSE
- Made of metal



### IGTP-805AT/IGTP-802T/ IGTP-802TS/IGTP-815AT

- 100/1000BASE-X single/ multi mode LC (SFP interface)
- 10/100/1000BASE-T with 802.3at PoE+ port x 1
- Link Fault Pass-through (LFP) support
- -40 to 75 degrees C operating temperature
- IP30 metal case, DIN-rail and wall-mountable



### IGTP-2205AT

- 2-port 10/100/1000BASE-T 802.3at PoE+
- 2-port 100/1000BASE-X SFP
- -40 to 75 degrees C wide operating temperature.
- Compact IP30 metal case
- 48~54V DC power input



### POE-163/POE-165

- 10/100/1000BASE-T "Data" input port x 1 (POE-163)
- 10/100/1000BASE-T "Data + Power" output port x 1 (POE-163)
- 10/100/1G/2.5G/5Gbps "Data" input port x 1 (POE-165)
- 10/100/1G/2.5G/5Gbps "Data + Power" output port x 1 (POE-165)
- Mid-span PSE
- Plastic compact size, internal 100-240V AC power supply



### IPOE-162

- 10/100/1000BASE-T "Data" input port x 1
- 10/100/1000BASE-T "Data + Power" output port x 1
- -40 to 75 degrees C operating temperature
- IP30 metal case, DIN-rail and wall-mountable



### IPOE-260/IPOE-260-12V

- 10/100/1000BASE-T "Data" input port x 2
- 10/100/1000BASE-T "Data + Power" output port x 2
- -40 to 75 degrees C operating temperature
- IP30 metal case, DIN-rail and wall-mountable



### IPOE-162S

- 10/100/1000BASE-T "Data" output port x 1
- 10/100/1000BASE-T "Data + Power" input port x 1
- Power output: 12V/24V DC, max. 2A
- -40 to 75 degrees C operating temperature
- IP30 metal case, DIN-rail and wall-mountable

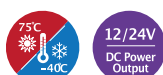

### POE-161S/POE-162S

- 10/100/1000BASE-T "Data" output port x 1
- 10/100/1000BASE-T "Data + Power" input port x 1
- Made from plastic
- Power output: 5V/12V DC, max. 5A (POE-161S)
- Power output: 12V/24V DC, max. 2A (POE-162S)





## 802.3af PoE Injectors

### POE/FTP Series

- Complies with IEEE 802.3af Power over Ethernet
- Data and power transmission distance up to 100 meters
- Maximum power up to 15.4 watts
- Auto-detection of PoE IEEE 802.3af equipment and devices from being damaged by incorrect installation
- Desktop size, wall-mountable

### FTP-802/802S15

- 10/100BASE-TX "Data + Power" output port x 1
- 100BASE-FX "Data" input port x 1
- End-span PSE
- Made of metal



## PoE Extenders

PLANET PoE Extenders are a newly-designed and simple device which extends both the reach of Ethernet data and power over the standard 100m (328 ft.) RJ45 UTP cable to 200m, 300m or longer distance, making the network installations more efficient and cost-effective.

### POE/IPOE-E Series

- Extends the range of PoE by an additional 100 meters (328ft.) or more
- Forwards both Ethernet data and PoE power to remote devices
- Multiple units, daisy-chain installation supported
- No external power cable required for installation
- Compact size, wall-mountable
- Plug and Play

## 802.3bt PoE++ Extenders

### IPOE-E174

- Forwards both Ethernet data and in-line power to 4 remote devices
- 1-port 802.3bt PoE++ PD
- 4-port IEEE 802.3af/at Power over Ethernet/end-span PSE
- Supports PoE output power up to 30.8 watts for each PoE port
- Extends the range of PoE for an additional 100 meters (328ft.)
- -40 to 75 degrees C wide operating temperature
- No external power cable required for installation
- Plug and Play, no software required



### POE-E304/WGS-E304PT

- Forwards both Ethernet data and in-line power to 4 remote devices
- 1-port 802.3bt PoE++ Power over Ethernet PD
- 4-port IEEE 802.3af/at Power over Ethernet/end-span PSE
- Supports PoE output power up to 30.8 watts for each PoE port
- Extends the range of PoE for an additional 100 meters (328ft.)
- No external power cable required for installation
- Plug and Play, no software required



### IPOE-E302/POE-E301

- 10/100/1000BASE-T "Data + Power" shielded RJ45 input port x 1, 802.3bt PoE++ PD compliant
- 10/100/1000BASE-T "Data + Power" shielded RJ45 output port x 2
- Max. total PoE budget up to 60 watts
- -40 to 75 degrees C wide operating temperature (IPOE-E302)
- Extends Cat.5 cable installations to beyond 100 meters



## 802.3at/af PoE Extenders

### POE-E201

- 10/100/1000BASE-T "Data + Power" output port x 1
- 10/100/1000BASE-T "Data + Power" input port x 1
- Complies with IEEE 802.3af/at Power over Ethernet mid-span
- Maximum extended distance up to 500m



### POE-E202

- 10/100/1000BASE-T "Data + Power" output port x 2
- 10/100/1000BASE-T "Data + Power" input port x 1
- Complies with IEEE 802.3af/at Power over Ethernet mid-span
- Maximum extended distance up to 300m



# Long Reach PoE L2/L4 IPv6 Managed Switches

LRP Series



PLANET Long Reach PoE (LRP) solution is designed to extend IP Ethernet transmission and inject power over an existing coaxial cable for distance up to 1000m (3280ft) into PoE IP camera, PoE wireless AP and any 802.3af/at complied powered device (PD).

The Long Reach PoE solution consists of an LRP switch/injector and LRP extender which can work without any power adapter anywhere on your network infrastructure. It is a perfect solution for sending IP video links and power to remote PoE IP camera installation that is beyond the 100-meter distance limit of Ethernet.

- Re-use the existing coaxial cable that eliminates power cabling with Power over coaxial (PoC)
- Data and Power over coaxial up to 1km
- Up to 36-watt power output per PoC port
- PD alive check, scheduled power recycling and time-based PoE schedule
- IEEE 802.1Q VLAN, Q-in-Q, Private VLAN and GVRP
- IEEE 802.1w RSTP, IEEE 802.1s MSTP and loop protection
- IGMP snooping v2 and v3 and MLD snooping
- QoS, Voice VLAN and bandwidth control
- Layer 2, 3 and 4 Access Control List
- IPv4 and IPv6 Web interface; Telnet; SNMP v1, v2c and v3; SSH and SSL management

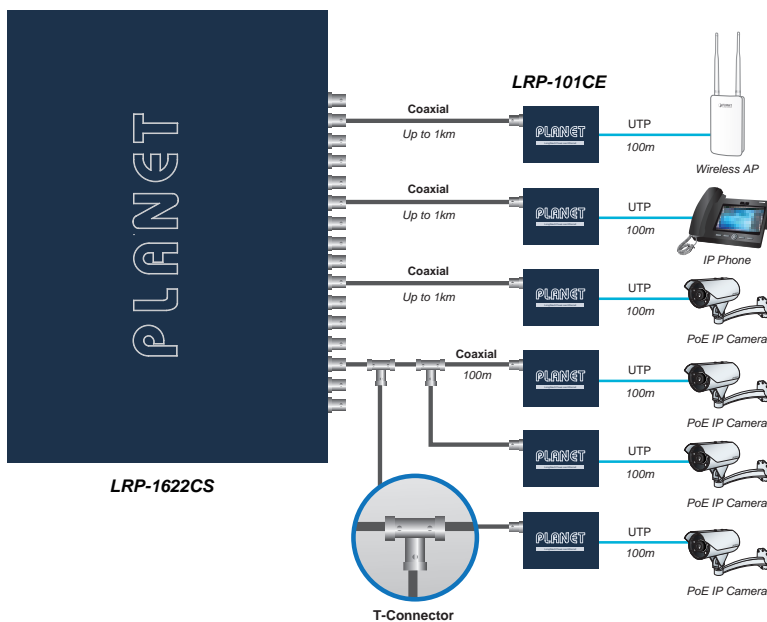

## LRP-822CS

- Long Reach PoE over coaxial port x 8
- 100/100/1000BASE-T port x 2
- 100/1000BASE-X SFP port x 2
- 240-watt PoE budget
- Up to 36 watts per PoC port
- Power over coaxial up to 1km

## LRP-1622CS

- Long Reach PoE over coaxial port x 16
- 100/100/1000BASE-T port x 2
- 100/1000BASE-X SFP port x 2
- 440-watt PoE budget
- Up to 36 watts per PoC port
- Power over coaxial up to 1km

## LRP-422CST

- Long Reach PoE over coaxial port x 4
- 100/100/1000BASE-T port x 2
- 100/1000BASE-X SFP port x 2
- 150-watt PoE budget
- Up to 36 watts per PoC port
- Power over coaxial up to 1km
- -20 to 75 degrees C operating temperature
- IP30 metal case, DIN-rail and wall-mountable

# Long Reach PoE Injectors & Extenders

LRP-101/LRP-111 series



The LRP-101/LRP-111 PoE Extender series, which sources power from the LRP switch or LRP injector, is a Single-port, 802.3at/802.3bt High Power over Ethernet Injector providing a maximum of up to 25/60 watts of power output over Ethernet cable which allows data and power to transmit simultaneously through the cable to PoE PD (Powered Device).

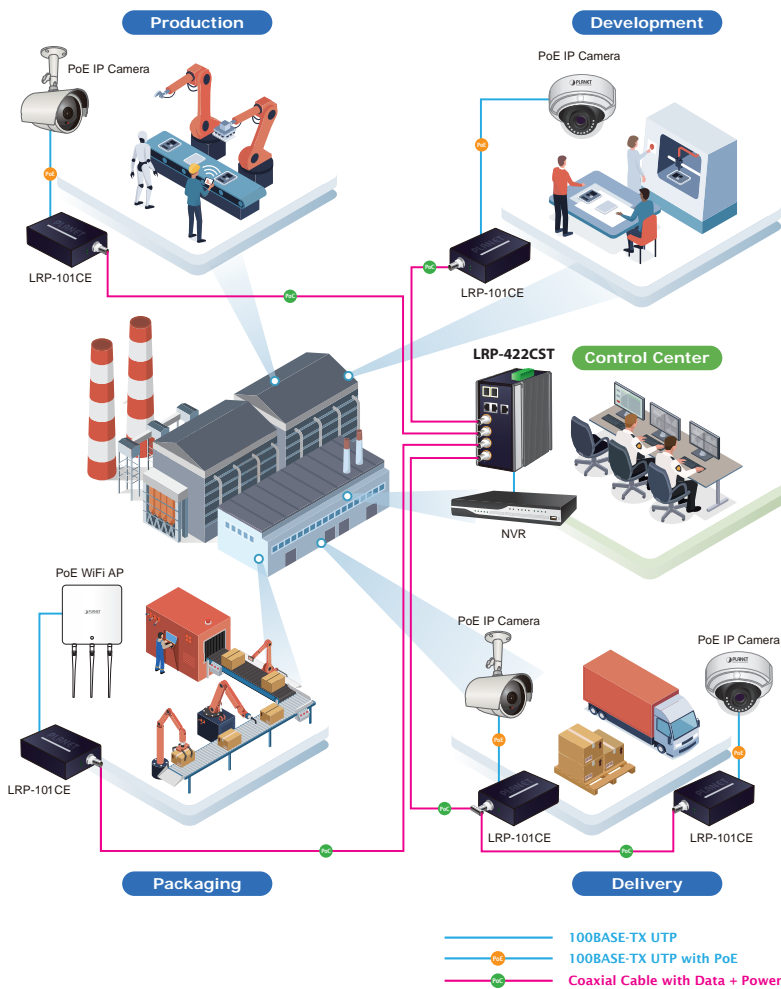

## Single Port Injector

### LRP-101CH

- 1-port BNC with passive PoE PSE
- 1-port 10/100TX RJ45 with 802.3at PoE+ Input
- -20 ~ 70 degrees C operating temperature
- Power over coaxial up to 1km

### LRP-101UH

- 1-port UTP with passive PoE PSE
- 1-port 10/100TX RJ45 with 802.3at PoE+ Input
- -20 ~ 70 degrees C operating temperature
- Power over UTP up to 500m

### LRP-111UH

- 1 Long Reach 90-watt PoE PSE Port with 100Mbps@500 meters or 10Mbps@800 meters
- 1-port 10/100TX RJ45 with 802.3bt PoE++ Input
- 48~54V DC or 802.3bt PoE++ power Input
- -40~75 degrees C operating temperature
- IP30 compact-sized case, DIN-rail or wall-mountable
- Co-works with LRP-111UE
- Power over UTP up to 800m

## Single Port Extender

### LRP-101CE

- 1-port BNC with passive PoE PD
- 1-port 10/100TX RJ45 with 802.3at PoE+ PSE to remote PoE IP camera/AP
- -20 ~ 70 degrees C operating temperature

### LRP-101UE

- 1-port UTP with passive PoE PD
- 1-port 10/100TX RJ45 with 802.3at PoE+ PSE to remote PoE IP camera/AP
- -20 ~ 70 degrees C operating temperature

### LRP-111UE

- 1 Long Reach PoE PD Port
- 1-port 10/100TX RJ45 with 60-watt 802.3bt PoE++ output
- PoE power input, no extra power adapter required
- -40~75 degrees C operating temperature
- IP30 compact-sized case, DIN-rail or wall-mountable
- Co-works with LRP-111UH



# All-Inclusive Fiber Optic Network Solution

## Telecom



### Layer 3 Chassis Switch

▶ CS-6306R/ CS6-S24S8X/ CS6-S16X/ CS6-S4Q

64 x 10G SFP+ | 16 x 40G QSFP+



## Enterprise



### L3 Fiber Managed Switches

▶ XGS3-2424Z/ SGS-6341-16S8C4XR/  
XGS-6350-12X8TR/ GS-6320-46S2C4XR

12 x 10G SFP+ Max.



## Data Center

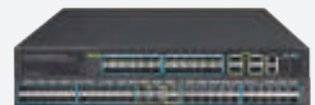

### Layer 3 100G Managed Switch

▶ XGS-6350-24X4C/ XGS-6350-48X2Q4C

24/48 x 10G SPF+ | 4 x 100G QSFP28



## Factory



### Industrial L3 Managed Switches

▶ IGS-6325-5X1T/ IGS-6325-8T8S/  
IGS-6325-8T8S4X

4 x 10G SFP+ | -40~75°C



## FTTx



### Metro Ethernet Switches

▶ MGSW-28240F/ MGSW-24160F  
MGSD-10080F/ MGS-6320-2T6S2X

4 x 10G SFP+ Max. | -10~60°C



## Building



### Commercial and Industrial 10G Media Converters

▶ XT-905A/ XT-915A/ XT-925A

2 x 10G SFP+ Max. | 1 x 10G BASE-T RJ45



# Media Conversion

## Centralized Media Converter Management



PLANET Media Converter Chassis allows the installation of up to 15 PLANET standard Media Converters with diverse choices, such as fiber, GEAPON, Ethernet, PoE, serial RS232/485 interfaces, VDSL2 and video to meet different network applications. It is very flexible for Media Converter series to be installed in the chassis for centralized media conversion management.

## Web/SNMP/OAM Remote Management

For efficient management, the Managed Media Converters are equipped with remote Web interface. They also support the standard SNMP and TS-1000/802.3ah OAM protocol and can be managed via any standard management software.



## Extension & Expansion

With the feature-rich chassis, the converters can easily expand the fiber-optic networks by simply plug and play. The wiring distance of PLANET Media Converter Chassis is extendable from 2 to 120 kilometers, and the Media Converter transmission distance is up to 120 kilometers.



DIN-rail Installation



Chassis Installation



Wall-mount Installation

## Easy Installation

With standard cases, PLANET Media Converters provide a 3-way installation, including DIN rail, chassis and wall mount, to manage all devices more efficiently.

## Environmentally Hardened Design

The Industrial Media Converter Series is equipped with the slim-type IP30 metal case for easy deployment in heavy Industrial demanding environments. Being able to operate under the temperature range from -40 to 75 degrees C, the Industrial Media Converter Series can be placed in almost any difficult environment.



# Managed Media Converter Chassis



For powerful advanced fiber-optic function and cost-effective solution, PLANET Managed Media Converter Chassis series, MC-1610MR/MC-1610MR48, provides 16 Media Converter slots and one management system in a 19" rack chassis. The MC-1610MR/MC-1610MR48 is designed for FTTH applications by ISPs, telecoms, campuses and enterprises.

The MC-1610MR/MC-1610MR48 helps to easily build the FTTH installation and perfectly satisfies diverse demands. The 16 slots can be flexibly applied with PLANET Fast/Gigabit Ethernet Smart Media Converter (FST-8/GST-8/XST series) to construct network solution of FTTH (Fiber to the Home), FTTB (Fiber to the Building) or FTTC (Fiber to the Curb) for ISPs, enterprises and campuses. The MC-1610MR/MC-1610MR48 is a reliable and efficient solution for network application where distance and installation budget are highly concerned.

- High-quality 19" rack-mountable chassis installation
- Bay power isolation ensures each bay is electrically isolated from each other
- Installation of up to two fans for increased air-flow for system cooling
- One 10/100/1000Mbps Ethernet port and one RS232 port for management
- LED indicators for system, power and fan status
- NTP client (Time zone setting)
- Remote syslog and local system log
- DHCP client and DNS client
- Temperature detects display and alarm
- Web firmware upgrade
- PLANET Smart Discovery Utility for deployment management
- Media link/connection speed duplex status for each converter module
- Redundant backup system (Redundant Link Media Converter)

## Web/SNMP management

- OAM
- Device Control
- Redundant Link
- Link Status Monitoring
- SNMP Trap Alarm



## MC-1610MR

- Console/Telnet/Web/SNMP management
- 16 hot-swappable modular converter management
- TS-1000/802.3ah OAM remote terminal management
- Two power slots for redundant power, optional AC/-48V DC supplies

## MC-1610MR48

- Console/Telnet/Web/SNMP management
- 16 hot-swappable modular converter management
- TS-1000/802.3ah OAM remote terminal management
- Two power slots for redundant power, optional AC/-48V DC supplies

## Hot-swappable/flexible power input



Dual AC



Dual DC



DC + AC

Power Module

## Smart Gigabit Media Converters



PLANET GST-80x Smart Gigabit Media Converter series extends communication distance with high Gigabit performance via fiber optic cable. The GST-80x series provides media conversion between 10/100/1000BASE-T and 1000BASE-SX/LX interfaces such as multi-mode LC/SC connectors (220m/550m), single-mode LC/SC connectors (10/20/40/80/120km) and single fiber connectors (WDM,20/60km) for various fiber optic applications.

- Complies with IEEE 802.3 10BASE-T, IEEE 802.3u 100BASE-TX, IEEE 802.3ab 1000BASE-T, IEEE 802.3z 1000BASE-SX/LX Ethernet standard
- Choice of fiber connectors from SC, LC, WDM, multi-mode/ single-mode fiber/1000BASE-SX/LX mini GBIC module
- Auto MDI/MDIX on TP port
- LLR /LLCF for fiber connection diagnostic
- IEEE 802.3ah OAM/TS-1000 OAM
- Manageable through MC-1610MR/MC-1610MR48
- LED indicators for converter status
- 9K jumbo frame size supported
- DIP switch for fiber (auto-negotiation/manual) and LFP function (disable/enable) setting
- EMI standards complies with FCC, CE class A

### GST-802

- One 1000BASE-SX port with SC connector
- Supports fiber optic up to 550m

### GST-802S

- One 1000BASE-LX port with SC connector
- Supports fiber optic up to 20km

### GST-805A

- One 1000BASE-SX/LX SFP slot
- Supports fiber optic up to 120km (Vary on SFP module)

### GST-806A15

- One 1000BASE-LX port with WDM connector
- Supports fiber optic up to 20km

### GST-806B15

- One 1000BASE-LX port with WDM connector
- Supports fiber optic up to 20km

### GST-806A60

- One 1000BASE-LX port with WDM connector
- Supports fiber optic up to 60km

### GST-806B60

- One 1000BASE-LX port with WDM connector
- Supports fiber optic up to 60km

## Smart Fast Ethernet Media Converters



PLANET Smart Fast Ethernet Media Converter, FST-80x series, extends communication distance with highly-stable performance via fiber optic cable. The FST-80x series provides media conversion between 10/100BASE-TX and 100BASE-FX interfaces such as multi-mode ST/SC connectors (2km), single-mode SC connector (15/35/50km), single fiber connector (WDM, 20km) and fiber connection options for various applications.

- Complies with IEEE 802.3 10BASE-T, IEEE 802.3u 100BASE-TX and 100BASE-FX Ethernet standard
- One 10/100BASE-TX port with RJ45 connector, one 100BASE-FX port with ST/SC/WDM connector supporting multi-mode or single-mode fiber optic cable
- Auto MDI/MDIX on TP port
- LLR/LLCF for fiber connection diagnostic
- Manageable through MC-1610MR/MC-1610MR48
- LED indicators for converter status
- DIP switch to set fiber (HDX/FDX), UTP (auto-negotiation/manual), speed (10/100Mbps), duplex mode (half/full duplex mode), LLR (disable/enable), LLCf (disable/enable), flow control (disable/enable) and LFP function (disable/enable)
- EMI standards complies with FCC, CE class B

### FST-801

- One 100BASE-FX port with ST connector
- Supports fiber optic up to 2km

### FST-802

- One 100BASE-FX port with SC connector
- Supports fiber optic up to 2km

### FST-802S15

- One 100BASE-FX port with SC connector
- Supports fiber optic up to 15km

### FST-802S35

- One 100BASE-FX port with SC connector
- Supports fiber optic up to 35km

### FST-802S50

- One 100BASE-FX port with SC connector
- Supports fiber optic up to 50km

### FST-806A20

- One 100BASE-FX port with WDM connector
- Supports fiber optic up to 20km

### FST-806B20

- One 100BASE-FX port with WDM connector
- Supports fiber optic up to 20km

# Smart 10Gigabit Media Converters



With target applications including 1Gbps, 2.5Gbps, 5Gbps and 10G Ethernet switching, PLANET XST-705A Smart 10Gigabit Media Converter is ideal for wide applications for copper to fiber media conversion wherever 10Gigabit bandwidth is required.

The XST-705A has one RJ45 port and one SFP+ slot. It supports 10Gigabit Ethernet conversion from copper 10GBASE-T to fiber multi-mode or single-mode, utilizing 10GBASE-SR or 10GBASE-LR SFP+ transceiver installed in the SFP+ slot to extend distances to server switches and patch panels. The deployment distance can be extended from 300 meters (multi-mode) to up to 80 kilometers (single-mode).

The XST-705A is designed for use in network environments where the ultra-high bandwidth provided by 10Gigabit Ethernet is required, for example, data center cloud computing, enterprise backbones, campus networks, and carrier infrastructure.

## Media Converter Chassis



Offering more capacity to the converters in one chassis, PLANET MC-700/MC-1500 provides 7/15 slots in the 10"-19" rack saving more spaces for fiber-optic wiring yet simplifying the maintenance of media conversion. It allows the connectivity of up to 7-/15-slot PLANET Fast Ethernet, Gigabit Ethernet or VDSL2 Converters in one chassis. One fan with LED indicators for the system cooling is also available.

Providing redundant power to gain more reliable media conversions, the MC-1500R/MC-1500R48 offers 15 slots for PLANET's full-ranging Media Converter series and 2 slots for 130W or DC -48V redundant power supply. It allows the connectivity of up to 15 PLANET Fast Ethernet, Gigabit Ethernet or VDSL2 Converters in one chassis. Two fans with LED indicators for the system cooling are also available.

The MC-700, MC-1500, MC-1500R and MC-1500R48 offer flexibility in installation and cost-effective scalable solution. With an independent power supply on each slot of the MC-700, MC-1500, MC-1500R and MC-1500R48, any converter is hot-swappable without causing an interruption to other converters. The Media Converters and power modules can be plugged and played anytime. Each bay of the Media Converter Chassis can be populated with any of PLANET's Media Converter series, the FT, GT, VC-23x and ICS, which provide media conversion between fiber optic, phone wire and serial to copper lines.

- High-quality 10"/19" rack-mountable chassis installation
- Bay power isolation ensures each bay is electrically isolated from each other
- Power protection: protection from over voltage, over current and short circuit
- One/two built-in fans for hardware cooling
- Supplies the converters and power modules to be plugged and played
- Reduces the effort of converter maintenance and management and diagnose the status at one time
- FCC Part 15 Class A, CE

### XST-705A

- One 10GBASE-X SFP+ slot, supporting up to 80km (Vary on SFP module)
- One 10G/5G/2.5G/1G/100M RJ45 copper port
- Complies with IEEE 802.3ae 10GBASE-R
- NBASE-T featuring adaptive rate operation
- 100 meters over Cat 6.A at 10Gbps
- Low power consumption
- Manageable through MC-1610MR/MC-1610MR48

### MC-700

- 7-slot hot-swappable
- LED indicators for system status monitoring
- Built-in AC power supply unit



### MC-1500

- 15-slot hot-swappable
- LED indicators for system status monitoring
- Built-in AC power supply unit



### MC-1500R

- 15-slot hot-swappable
- LED indicators for system status monitoring
- One AC 100-240V power input
- Redundant power supply with option of 100~240V AC or -48V DC

### MC-1500R48

- 15-slot hot-swappable
- LED indicators for system status monitoring
- One DC -48V power input
- Redundant power supply with option of 100~240V AC or -48V DC



MC-1500R Rear Panel



# 10G Media Managed Converters



PLANET XT-900 series high-performance media converter improves network connectivity and provides sophisticated management capabilities. It is the first 10G media converter in the industry with standalone secure management, making it the best option for enterprise and telecom remote management and monitoring. The XT-900 series allows for remote management via an intuitive web interface, command line interface (CLI) and SNMP protocol, enabling easy monitoring and configuration of the converter from anywhere.

Our cutting-edge converter features one 10GBASE-T copper port and two 10G SFP+ ports, providing ultra-fast connectivity for devices with RJ45 interfaces as well as greater flexibility in fiber-optic cabling options. This powerful yet compact solution makes it the ideal choice for businesses looking to boost their network speed and functionality.

With target applications including 10Gbps Ethernet switching and aggregation, PLANET's IXT-900 series is ideal for scenarios needing high-bandwidth data transmission. These converters are especially suitable for environments such as data centers, campus backbones, and ISP networks.

The IXT-900 series features one RJ45 port and two SFP+ slots, allowing for 10G Ethernet media conversion from copper to fiber, with distances extended from 300 meters (multi-mode) to 80 kilometers (single-mode). Additionally, models like IXT-900-1X1UP and IXT-900-2X1UP support IEEE 802.3bt PoE++, providing up to 95W per port—ideal for high-consumption devices like IP cameras and access points.

Designed for demanding environments, the IXT-900 series operates from -40 to 75°C, with an IP40 case to resist electromagnetic interference. Its rugged design ensures reliable performance on factory floors and in outdoor cabinets.

## XT-905A

- One 10GBASE-X port
- One 10G/5G/2.5G/1G/100M RJ45 copper
- Support Link-Fault Pass-through (LFP) feature
- Support the IEEE 802.1Q VLAN standard
- Web, CLI and SNMP management
- Supports ITU-G.8032 Ethernet Ring Protection Switch (ERPS)

## XT-915A

- Two 10GBASE-X ports double the Distance of Deployment
- Support Link-Fault Pass-through (LFP) feature
- Support the IEEE 802.1Q VLAN standard
- Web, CLI and SNMP management
- Supports ITU-G.8032 Ethernet Ring Protection Switch (ERPS)

## XT-925A

- Two 10GBASE-X ports double the Distance of Deployment
- One 10G/5G/2.5G/1G/100M RJ45 copper
- Support Link-Fault Pass-through (LFP) feature
- Support the IEEE 802.1Q VLAN standard
- Web, CLI and SNMP management
- Supports ITU-G.8032 Ethernet Ring Protection Switch (ERPS)

## IXT-900-1X1T/IXT-900-2X1T

- One/Two 10GBASE-X SFP+ port
- One 10G/5G/2.5G/1G/100BASE-T RJ45 port
- Supports Link Fault Pass-through (LFP) for quick fault detection
- Compliant with IEEE 802.1Q VLAN standard
- Web, CLI, and SNMP management interfaces
- Supports ITU-T G.8032 Ethernet Ring Protection Switching (ERPS)

## IXT-900-2X

- Two 10GBASE-X SFP+ fiber ports
- Supports single-mode and multi-mode conversion up to 80km
- Link Fault Pass-through (LFP) feature for enhanced fault detection
- Compliant with IEEE 802.1Q VLAN standard
- Supports ITU-T G.8032 Ethernet Ring Protection Switching (ERPS)
- IPv4/IPv6 dual-stack management for flexible network integration

## IXT-900-2X1PD

- Two 10GBASE-X SFP+ ports and one 10G/5G/2.5G/1G/100BASE-T RJ45 port with PoE PD support
- Supports Link Fault Pass-through (LFP) for enhanced fault detection
- Compliant with IEEE 802.1Q VLAN standard
- IPv4/IPv6 dual stack management for flexible network integration
- Supports ITU-T G.8032 Ethernet Ring Protection Switching (ERPS)
- Designed for operation in extreme environments (-40 to 75°C)

## IXT-900-1X1UP/IXT-900-2X1UP

- One/Two 10G/5G/2.5G/1G/100BASE-T RJ45 port with IEEE 802.3bt PoE++ support
- One 10GBASE-X SFP+ port
- Intelligent PoE alive check and scheduled power recycling to enhance reliability
- Supports Link Fault Pass-through (LFP) for fast fault detection
- IPv4/IPv6 dual-stack management
- Supports ITU-T G.8032 Ethernet Ring Protection Switching (ERPS)
- Environmentally hardened design for temperatures ranging from -40 to 75°C

# 10G Ethernet Media Converter



With target applications including 1Gbps, 2.5Gbps, 5Gbps and 10G Ethernet switching and aggregation, PLANET IXT and XT 10G Media converter series is ideal for wide applications for copper to fiber media conversion wherever 10Gigabit bandwidth is required.

The IXT and XT series has one RJ45 port and one SFP+ slot. It supports 10Gigabit Ethernet media conversion from copper 10GBASE-T to fiber multi-mode or single-mode, utilizing 10GBASE-SR or 10GBASE-LR SFP+ transceiver installed in the SFP+ slot to extend distances to servers, switches and patch panels. The deployment distance can be extended from 300 meters (multi-mode) to up to 80 kilometers (single-mode).

The IXT series is designed for use in network environments where the ultra-high bandwidth provided by 10Gigabit Ethernet is required, for example, data center cloud computing, enterprise backbones, campus networks, and carrier infrastructure.

## XT-705A

- One 10GBASE-X SFP+ slot
- One 10G/5G/2.5G/1G/100M RJ45 copper
- Complies with IEEE 802.3ae 10GBASE-R
- NBASE-T featuring adaptive rate operation
- 100 meters over Cat 6A at 10Gbps
- Low power consumption
- Compact size; compatible with MC-700/ MC-1500 Chassis

10G SFP+ NBASE-T

## XT-715A

- One 10GBASE-X SFP+ slot
- One 10G/5G/2.5G RJ45 copper
- Complies with IEEE 802.3ae 10GBASE-R
- NBASE-T featuring adaptive rate operation
- 100 meters over Cat 6A at 10Gbps
- Low power consumption
- Compact size; compatible with MC-700/ MC-1500 Chassis

## XT-815A

- Two 10G/2.5G/1GBASE-X SFP+ slots
- Complies with IEEE 802.3ae 10GBASE-R
- Low power consumption
- Compact size; compatible with MC-700/ MC-1500 Chassis

## IXT-705AT

- One 10GBASE-X SFP+ slot
- One 10G/5G/2.5G/1G/100M RJ45 copper
- Complies with IEEE 802.3ae 10GBASE-R
- NBASE-T featuring adaptive rate operation
- 100 meters over Cat 6A at 10Gbps
- -40~75 degrees C operating temperature
- IP30 metal case
- Low power consumption

10G SFP+ NBASE-T

# Gigabit Managed Media Converters



PLANET GT-91x series provides much flexibility with all kinds of 10/100/1000Mbps Ethernet Media on RJ45 port and offers highly stable Gigabit fiber performance. It supports conversion between 10/100/1000BASE-T and 1000BASE-LX/SX network, which includes SFP/WDM connectors with single-mode or multi-mode media as required.

For efficient management, PLANET GT-91x Managed Gigabit Ethernet Media Converter series is equipped with remote Web/SNMP interface. With its built-in Web-based management, PLANET GT-91x series acts as an easy-to-use, platform-independent management and configuration facility.

- Complies with IEEE 802.3 10BASE-T, IEEE 802.3u 100BASE-TX, 100BASE-FX, IEEE 802.3ab 1000BASE-T, IEEE 802.3z 1000BASE-SX/LX
- Choice of fiber connectors: LC, WDM, multi-mode/single-mode
- LED indicators for easy network diagnostics
- Auto MDI/MDIX on TP port
- IP-based web interface
- SNMP v1/v2c monitor
- 802.1Q/Q-in-Q/Management VLAN
- Maximum frame size up to 16K bytes
- TS-1000 OAM/IEEE 802.3ah OAM/Loop Back Test
- Compact in size, easy installation
- 10-/19-inch chassis compatibility (MC-700/MC-1500/MC-1500R/MC-1500R48)

## Gigabit Media Converters



For the flexibility of all kinds of 10/100/1000Mbps Ethernet Media on RJ45 port and highly-stable Gigabit fiber performance, PLANET GT-802, GT-802S, GT-805A and GT-806A/B series and GT-1205A Gigabit Ethernet Media Converter extend communication distance with Gigabit performance via fiber optic cable. The GT-80x series and GT-1205A provide media conversion between 10/100/1000BASE-T and 1000BASE-SX/LX interfaces for various fiber optic applications.

- Complies with IEEE 802.3 10BASE-T, IEEE 802.3u 100BASE-TX, IEEE 802.3ab 1000BASE-T, IEEE 802.3z 1000BASE-SX/LX
- IEEE 802.3x full-duplex flow-control and back-pressure in half-duplex eliminate the loss of packets
- Auto MDI/MDIX on TP port
- 9K jumbo frame
- OAM terminal (TS-1000 and IEEE 802.3ah)
- LED indicators for easy network diagnostics
- External 5V/2A DC power supply
- Wall mounting and DIN-rail supported
- Compact in size, easy installation
- 10-/19-inch chassis compatibility (MC-700/MC-1500/MC-1500R/MC-1500R48)

### GT-915A

- One 1000BASE-SX/LX SFP slot
- Supports fiber optic up to 120km (depending on SFP module)

### GT-802/GT-802S

- One 1000BASE-SX port with SC connector
- Supports fiber optic up to 550m
- Supports fiber optic up to 20km

### GT-805A

- One 1000BASE-SX/LX SFP slot
- Supports fiber optic up to 120km (Vary on SFP module)

### GT-806A15/GT-806B15

- One 1000BASE-LX port with WDM connector
- Supports fiber optic up to 20km

### GT-806A40/GT-806B40

- One 1000BASE-LX port with WDM connector
- Supports fiber optic up to 40km

### GT-806A60/GT-806B60

- One 1000BASE-LX port with WDM connector
- Supports fiber optic up to 60km

### GT-1205A

- Dual100/1000BASE-X mini-GBIC SFP slot
- DIP Switch for 100FX or 1000X SFP supports on dual SFP slots
- Supports fiber optic up to 120km (depending on SFP module)
- One 10/100/1000BASE-T Copper Port
- 3-port switch mode or redundant mode
- Hardware fiber port redundancy
- IEEE 802.3x flow control

### GT-805A-PD

- PoE Powered
- Compliant with 802.3af/at
- PoE/5V DC dual power input
- One 1000BASE-SX/LX SFP slot
- Supports fiber optic up to 120km (Vary on SFP module)

# Gigabit PoE Media Converters



As more demand for PoE powered devices needs higher power input and long distance transmission, PLANET GTP-805A/GUP-805A-60W/GUP-805A-95W PoE Media converter series is an ideal solution for this kind of PoE applications.

The GTP-805A IEEE 802.3at PoE+ media converter supports a maximum of 30-watt PoE output. The GUP-805A-60W and GUP-805A-95W IEEE 802.3bt PoE++ are capable to source up to 60 watts and 95 watts of power by using all the four pairs of standard Cat5e/6 Ethernet cabling to deliver power and full-speed data to each remote PoE-compliant powered device (PD).

With complete power budget solutions of 30 watts, 60 watts and 95 watts for different kinds of PoE applications, the GTP-805A, GUP-805A-60W and GUP-805A-95W provide a quick, safe and 802.3at PoE+/802.3bt PoE++ network solution for small businesses and enterprises.

## GTP-805A

- One 100/1000BASE-X SFP slot
- Supports fiber optic up to 120km (vary on SFP module)
- One 10/100/1000BASE-T Port with IEEE 802.3 at PoE+ 30W Power output

## GUP-805A-60W

- One 100/1000BASE-X SFP Slot
- Supports fiber optic up to 120km (vary on SFP module)
- One 10/100/1000BASE-T Port with IEEE 802.3 bt PoE++ 60W Power output

## GUP-805A-95W

- One 100/1000BASE-X SFP Slot
- Supports fiber optic up to 120km (vary on SFP module)
- One 10/100/1000BASE-T Port with IEEE 802.3 at PoE++95W Power output

# Fast Ethernet Media Converters

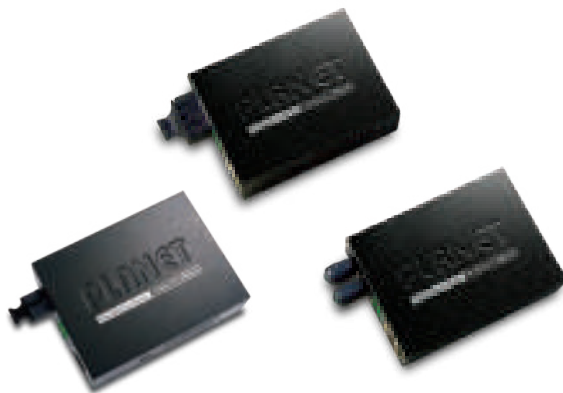

PLANET FT-80x series is a Fast Ethernet Bridge 100BASE-FX fiber to 10/100BASE-TX shielded twisted pair (STP) converter. It supports both half-duplex and full-duplex operations and a variety of fiber options. The converter automatically adapts to the highest level of performance supported by the device connected to the STP port.

- Complies with IEEE 802.3, IEEE 802.3u 10/100BASE-TX, 100BASE-FX
- IEEE 802.3x full-duplex flow-control and back-pressure in half-duplex eliminate the loss of packets
- Auto MDI/MDIX on TP port
- Rear DIP switch for FX duplex mode selection
- Side DIP switch for LFP mode selection
- LED indicators for easy network diagnostics
- External 5V/2A DC power supply
- Wall mounting and DIN-rail supported
- Compact in size, easy installation
- 10-/19-inch chassis compatibility (MC-700/MC-1500/MC-1500R/MC-1500R48)

## FT-801

- One 100BASE-FX port with ST connector
- Supports fiber optic up to 2km

## FT-802

- One 100BASE-FX port with SC connector
- Supports fiber optic up to 2km

## FT-802S15

- One 100BASE-FX port with SC connector
- Supports fiber optic up to 15km

## FT-802S35/FT-802S50

- One 100BASE-FX port with SC connector
- Supports fiber optic up to 35km
- Supports fiber optic up to 50km

## FT-806A20/FT-806B20

- One 100BASE-FX port with WDM connector
- Supports fiber optic up to 20km

## FT-806A60/FT-806B60

- One 100BASE-FX port with WDM connector
- Supports fiber optic up to 60km

# VDSL2 Media Converters



PLANET VC series is Ethernet-over-VDSL2 Media Converter with high performance. It is based on two core networking technologies, Ethernet and VDSL2 (Very-high data-rate Digital Subscriber Line 2). The VDSL2 technology offers the absolutely fastest data transmission speeds over the existing copper telephone lines without the need of rewiring.

The VC series can be used as a standalone unit when powered by its DC adapter or used as a slide-in module to PLANET 10-/19-inch 7-/15-slot Media Converter Chassis (MC-700/MC-1500/MC-1500R/MC-1500R48).

- Complies with IEEE 802.3 10BASE-T, IEEE 802.3u 100BASE-TX and IEEE 802.3x flow control Ethernet standards
- CO/CPE selectable via DIP switch
- DMT (Discrete Multi-Tone) line coding
- IEEE 802.1Q VLAN tag transparent, 1536 bytes packet size support
- LED indicators for easy network diagnostics
- External DC 5V 2A power supply
- Wall mounting and DIN-rail supported
- Compact in size, easy installation
- 10-/19-inch chassis compatibility (MC-700/MC-1500/MC-1500R/MC-1500R48)

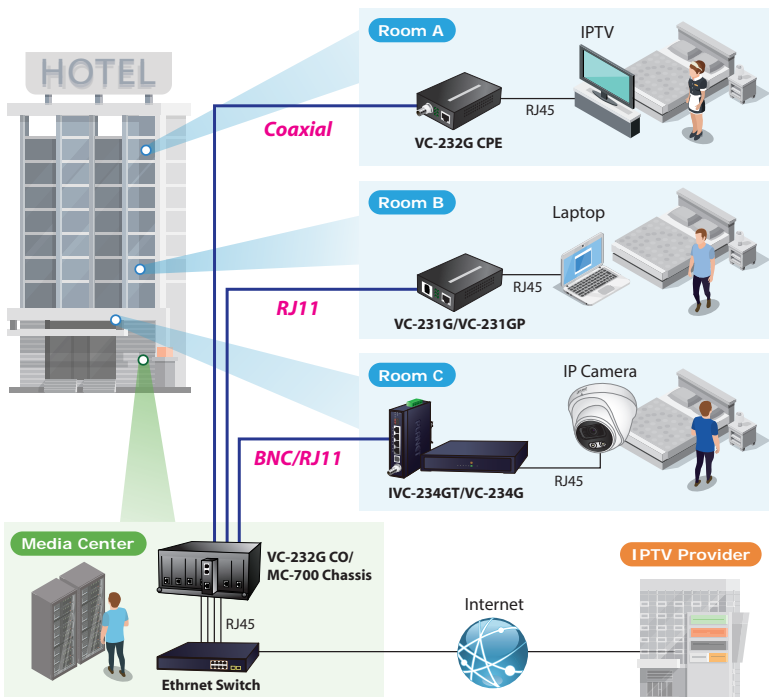

## VC-231

- ITU-T G.993.2 VDSL2 (Profile 17a/30a)
- One RJ11 connector for VDSL2 connection with up to 1.4km distance support

## VC-231G/VC-231GP

- One RJ11 connector for VDSL2 connection
- One 10/100/1000BASE-T RJ45
- ITU-T G.993.5 G.vectoring and G.INP
- Upstream/Downstream bandwidth up to 200/100Mbps
- CO/CPE mode selectable via DIP switch
- Selectable target band plan and SNR margin
- 30-watt 802.3at PoE+ PSE (VC-231GP)

## VC-232G

- One BNC connector for VDSL2 connection
- Uses existing RG59/RG6 coaxial cable
- One 10/100/1000BASE-T RJ45
- ITU-T G.993.5 G.vectoring and G.INP
- Upstream/Downstream bandwidth up to 200/100Mbps
- CO/CPE mode selectable via DIP switch
- Selectable target band plan and SNR margin

## VC-234G/IVC-234GT

- One RJ11 connector for VDSL2 connection
- One phone connector for telephone connection
- Four 10/100/1000BASE-T RJ45
- ITU-T G.993.5 G.vectoring and G.INP
- Upstream/Downstream bandwidth up to 200/100Mbps
- CO/CPE mode selectable via DIP switch
- Selectable target band plan and SNR margin
- -40 to 75 degrees C operating temperature (IVC-234GT)

## VC-231GF

- One RJ11 connector for VDSL2 connection
- One 1000BASE-X SFP
- ITU-T G.993.5 G.vectoring and G.INP
- Upstream/Downstream bandwidth up to 200/100Mbps
- CO/CPE mode selectable via DIP switch
- Selectable target band plan and SNR margin

# Serial over Ethernet Media Converters



PLANET ICS-10x Media Converter/Device Server series can convert Serial RS232/RS422/RS485 communication interface over Fast Ethernet networking. There are RJ45 and SC type connectors and single-mode/multi-mode media for customers' needs. Ethernet signal allows two types of segments to connect easily and efficiently.

- Complies with IEEE 802.3, IEEE 802.3u 10/100BASE-TX, 100BASE-FX standard
- Choice of fiber connectors: SC/LC, multi-mode/single-mode fiber
- IP-based web interface
- SMTP e-mail for alarm notification of events
- LED indicators for easy network diagnostics
- PLANET Smart Discovery utility finds ICS-10x devices on the network automatically
- Firmware upgrade via HTTP protocol
- Reset button on the front panel for reset to factory default
- Wall mounting and DIN-rail supported
- Compact in size, easy installation
- 10-/19-inch chassis compatibility (MC-700/MC-1500/MC-1500R/MC-1500R48)

## Standalone Installation - Device Gateway Server

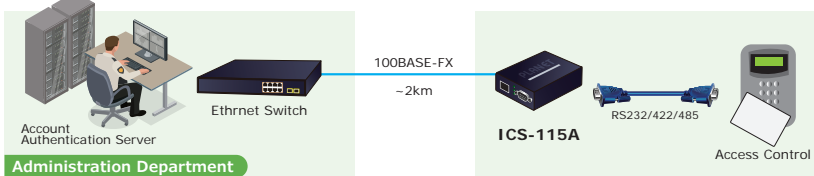

## Pair Connection - Local to Remote Serial Extension

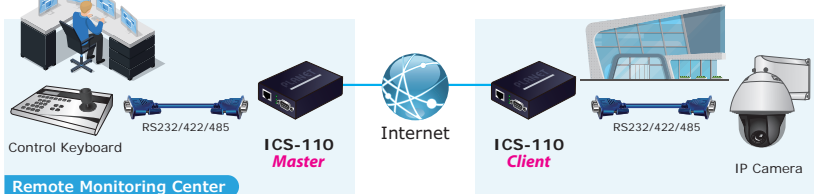

### ICS-110

- One DB9 interface supports RS232, 2-wire RS485, 4-wire RS485 and RS422 operation
- 1-port 10/100BASE-TX RJ45 interface with auto MDI/MDI-X function

### ICS-115A

- One DB9 interface supports RS232, 2-wire RS485, 4-wire RS485 and RS422 operation
- 1-port 100BASE-FX SFP slot

### ICS-120

- Two DB9 interfaces support RS232, 2-wire RS485, 4-wire RS485 and RS422 operation
- 1-port 10/100BASE-TX

## RS422/RS485 Modbus Gateway



PLANET MG-11x/MGS-12x 1/2-port RS232/422/485 Modbus Gateway supports converting any Modbus Protocols between Modbus TCP, Modbus RTU, and Modbus ASCII for all supported hardware interfaces. Its serial protocol can be used for industrial automation where SCADA or HMI system is in place, which brings interconnection over Ethernet longer distances, thus making a network infrastructure more flexible.

- Complies with IEEE 802.3, IEEE 802.3u 10/100BASE-TX, 100BASE-FX Standard
- 10/100TX RJ45 and 100FX SFP Interfaces
- Built-in IP-based Web interface
- Modbus TCP, Modbus RTU, Modbus ASCII, IP, ARP, DHCP and DNS
- RTU Master, RTU Slave, ASCII Master, and ASCII Slave serial operation modes
- Master mode supports 32 slave TCP connection requests
- Slave mode supports 32 TCP master connections
- Firmware upgrade/configuration backup and restore via HTTP protocol
- Reset button for resetting to factory default
- Wall-mount or DIN-rail installation
- -10 to 60 degrees C operating temperature
- 10-/19-inch chassis compatibility (MC-700/MC-1500/MC-1500R/MC-1500R48)

## Video over Fiber Optic Converters



PLANET has developed the video over Gigabit fiber media converter kit, VF-101G/102G/106G/402-KIT, which is ideal for extending the distance and signal conversion by transmitting the AHD/CVI/TVI/CVBS video and data over the fiber-optic cable.

The VF-10xG series and VF-402 include different types of fiber connectors such as ST, FC and WDM-SC which enable CCTV applications to replace the traditional coaxial cable with stable fiber cable performing more efficiently.

Adopting the intelligent encoding/decoding technology and with the compact box, the VF-10xG-KIT video over fiber media converter series enables videos to be delivered in high quality over a distance of up to 20km long.

- High-speed synchronous digital transmission technology
- 8-/10-bit digital video signal sampling
- Data type: RS485
- PAL, NTSC, SECAM compatible
- Long-distance data transmission of 20km
- Guarantees safe transmission under poor electromagnetic environment
- Compliant with hybrid video (AHD/TVI/CVI/CVBS)
- Compact size, wall mounting and DIN-rail supported, easy installation
- Standalone or work with PLANET MC-700/1500/1500R media converter chassis (For VF-10XG series)

### MG-110

- One DB9 interface supports RS232, 2-wire RS485, 4-wire RS485 and RS422 operation
- 1-port 10/100BASE-TX RJ45 with auto MDI/MDI-X function

### MG-115A

- One DB9 interface supports RS232, 2-wire RS485, 4-wire RS485 and RS422 operation
- 1-port 100BASE-FX SFP

### MG-120

- Two DB9 interfaces support RS232, 2-wire RS485, 4-wire RS485 and RS422 operation
- 1-port 10/100BASE-TX RJ45 with auto MDI/MDI-X function

### VF-101G-KIT

- Compliant with hybrid video (AHD/TVI/CVI/CVBS)
- ST multi-mode fiber connector
- Long-distance data transmission of 20km
- Wide temperature range from -25 to 70 degrees C

### VF-102G-KIT

- Compliant with hybrid video (AHD/TVI/CVI/CVBS)
- FC multi-mode fiber connector
- Long-distance data transmission of 20km
- Wide temperature range from -25 to 70 degrees C

### VF-106G-KIT

- Compliant with hybrid video (AHD/TVI/CVI/CVBS)
- WDM-SC multi-mode fiber connector
- Long-distance data transmission of 20km
- Wide temperature range from -25 to 70 degrees C

### VF-402-KIT

- Compliant with hybrid video (AHD/TVI/CVI/CVBS)
- FC multi-mode fiber connector
- Long-distance data transmission of 20km
- Wide temperature range from -20 to 70 degrees C
- Fiber optic transmission of four video signals on one fiber with RS485 data signals

# High-Performance Internet Solution for FTTx and Triple Play Applications



**GPON**

**VDSL2**



GPON ONTs/HGUs



VDSL2 Converter



IPTV



Internet



Online Gaming



VoIP via Wi-Fi



# Broadband Communication

PLANET Last Mile Transmission Solution provides not only CO (Central Office) side of equipment for ISPs but also CPE (Customer Premises Equipment) side of device for end users. Its high bandwidth certainly meets the requirements of triple play devices for today's home entertainment and communications.



## Delivering Highly-demanding Connectivity for ISPs/Triple Play Devices

With the capability of 100/100Mbps symmetric data transmission, PLANET VDSL2 Solution enables many multi-media services, such as VoD (Video on Demand), Voice over IP, video phone, IPTV, Internet caching server, distance education and so on, to work on the Internet without any reservation.

## 1.25Gbps High-speed and 20km Long-distance Coverage for Triple Play Services

PLANET GEAPON/GPON Solution provides a high bandwidth of up to 1.25Gbps for both upstream and downstream, and a long-distance coverage of up to 20km between equipment nodes for network deployment, thereby meeting the demand of increasing home multimedia and entertainment.



# xPON



## High-performance GPON for FTTH Applications

PLANET GPL-8000 GPON Optical Line Terminal (OLT) consists of eight GPON ports, four Gigabit TP/SFP combo ports, four Gigabit SFP ports, four 10G SFP+ ports and one management port. It provides a high bandwidth of up to 2.5Gbps for downstream and 1.25Gbps for upstream, complies with ITU-T G.984/G.988 and meets GPON OLT requirements regulated in network access technical requirements. It is easy to install and maintain a GPON deployment of up to 1024 ONU and HGU devices, providing highly-effective GPON solutions and convenient management for fiber optic broadband network.

- Complies with ITU-T G.984/G.988
- Up to 128 ONTs split ratio per port
- Distance up to 20km
- Up to 2.5Gbps downstream and 1.25Gbps upstream
- Each PON port supports up to 128 ONT/HGU
- IEEE 802.1Q tagged VLAN and Q-in-Q VLAN supported
- Optional redundant power design with dual-AC or AC+DC supported

## Fiber To The Home (FTTH) Application

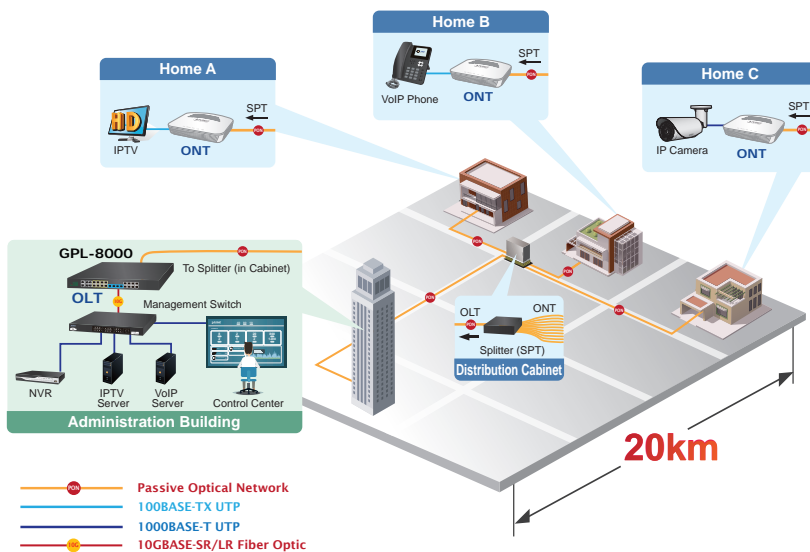

### GPL-8000

#### GPON OLT

- 8 PON ports, 8 1G SFP ports, 8 1G/10G SFP+ ports and 4 Gigabit RJ45 interfaces
- Complies with ITU-T G.984/G.988
- Per PON supports 128 ONT/HGU devices
- Asymmetric downlink 2.5Gbps/uplink 1.25Gbps
- Distance up to 20km
- IEEE 802.1Q tagged VLAN and Q-in-Q VLAN supported
- User-friendly GUI management
- Optional redundant power design with dual-AC or AC+DC supported

### GPN-100

#### xPON ONT

- One 10/100/1000 RJ45 port
- Up to 2.5Gbps downstream and 1.25Gbps upstream
- Distance up to 20km
- Compliant with ITU-T G.984/988
- Supports IGMP snooping and SLA
- Supports DBA and QoS

### GPN-400ACV

#### xPON HGU

- Built-in 4-port 100/1000Mbps Ethernet
- 2 FXS ports for VoIP communication
- 1 USB 2.0 port for configuration backup
- Complies with ITU G.984/988
- Up to 2.5Gbps downstream and 1.25Gbps upstream
- Compatible with 802.11ac/n wireless technology with data rate of up to 1200Mbps

### EPL-SPT-8/EPL-SPT-32/ EPL-SPT-64

#### xPON Splitter

- 1 : 8 high split ratio (EPL-SPT-8)
- 1 : 32 high split ratio (EPL-SPT-32)
- 1 : 64 high split ratio (EPL-SPT-64)
- Wide operating wavelength: 1260nm to 1650nm
- Wide operating temperature: -40 to 85 degrees C

# VDSL2 Bridges/Routers



## High-Performance VDSL2 Data Rate over Existing Phone Lines

PLANET 30a VDSL2 Solution contains various VDSL2 CPE (customer premises equipment) models for telecoms, ISPs (internet service providers), SIs (system integrators), IP surveillance providers, etc. It is based on two core networking technologies -- Ethernet and VDSL2 (very-high-data-rate digital subscriber line 2). The total VDSL2 solution offers the absolutely fastest data transmission speeds over the existing cooper telephone lines without the need of rewiring. The ideal xDSL technology provides the best solution to the last-mile connectivity.

## Ethernet over VDSL2 Converter

- One box design, CO/CPE selectable via DIP switch
- ITU-T G.993.2 VDSL2 (Profile 17a or Profile 30a)
- Built-in POTS splitter
- Compact in size, easy installation
- 10-/19-inch chassis compatible (MC-700/MC-1500/1500R)

## VDSL2 Point to Point Application for Best Performance

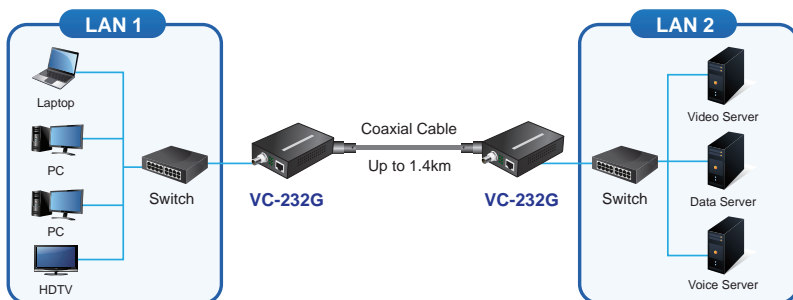

## VDSL2 Point to Multi-Point Application for Flexible Deployments

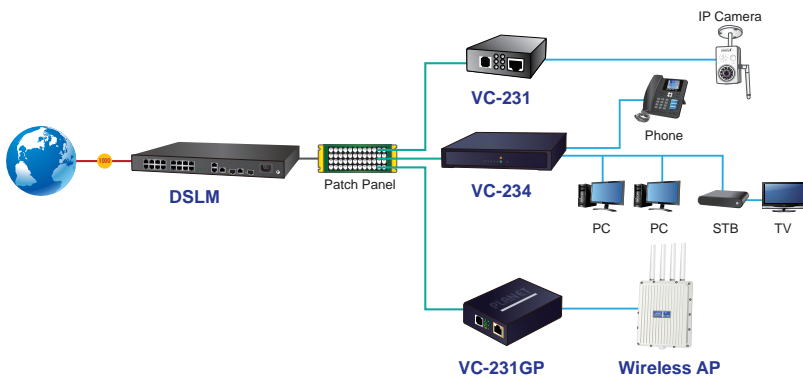

### VC-231

High bandwidth 10/100TX over VDSL2 Media Converter

- VDSL2 ITU-T G.993.2 30a profile
- 100/100Mbps download/upload @1000ft
- 1-port 10/100BASE-TX RJ45

### VC-234

High bandwidth 4-port 10/100TX to VDSL2 Bridge

- VDSL2 ITU-T G.993.2 30a profile
- 100/100Mbps download/upload @1000ft
- 4-port 10/100BASE-TX RJ45

### VC-231G/VC-231GP

1-port 10/100/1000T Ethernet over VDSL2 Media Converter

- One RJ11 connector for VDSL connection
- One 10/100/1000BASE-T RJ45
- ITU-T G.993.5 G.vectoring and G.INP
- Upstream/Downstream bandwidth up to 200/100Mbps
- CO/CPE mode selectable via DIP switch
- Selectable target band plan and SNR margin
- 30-watt 802.3at PoE+ PSE (VC-231GP)

### VC-231GF

1-port 1000X SFP Fiber Ethernet over VDSL2 Media Converter

- One RJ11 connector for VDSL connection
- One 1000BASE-X SFP
- ITU-T G.993.5 G.vectoring and G.INP
- Upstream/Downstream bandwidth up to 200/100Mbps
- CO/CPE mode selectable via DIP switch
- Selectable target band plan and SNR margin

### VC-232G

1-port 10/100/1000T Ethernet over Coaxial Media Converter

- One BNC connector for VDSL connection
- Uses existing RG59/RG6 coaxial cable
- One 10/100/1000BASE-T RJ45
- ITU-T G.993.5 G.vectoring and G.INP
- Upstream/Downstream bandwidth up to 200/100Mbps
- CO/CPE mode selectable via DIP switch
- Selectable target band plan and SNR margin

### VC-234G/IVC-234GT

4-port 10/100/1000T Ethernet to VDSL2 Bridge

- One RJ11 connector for VDSL connection
- One phone connector for telephone connection
- Four 10/100/1000BASE-T RJ45
- ITU-T G.993.5 G.vectoring and G.INP
- Upstream/Downstream bandwidth up to 200/100Mbps
- CO/CPE mode selectable via DIP switch
- Selectable target band plan and SNR margin

# Comprehensive Centralized Wireless AP Management Solution



| Optimizing Wireless Network within Minutes |



Indoor Managed  
Access Points

Outdoor Managed  
Access Points

Industrial Managed  
Access Points



# Wireless LAN

## Centralized Wireless LAN Management via Network Management System

Designed for large-scale wireless network in smart cities, such as hotels, shopping malls, SMBs, buildings and any public area, PLANET's Centralized Wireless LAN Management Solution can centrally manage up to 1,02,400 indoor and outdoor wireless APs via PLANET's Universal Network Management System (UNI-NMS) or DDNS cloud portal.



## Efficient AP Positioning

With the simplified Cluster AP management including Multi SSIDs, Zone Plan and Google Map, the administrator can automatically discover, configure, monitor and locate all the managed APs without configuring each AP one by one, thus greatly optimizing the wireless network performance.

## Comprehensive and User-friendly AP Control

PLANET's Centralized Wireless LAN Management Solution provides the browser-based dashboard and graphical data analysis to show the administrator valuable wireless network information at a glance. Moreover, the Wireless Controllers come with an intuitive color touch LCD or LCD control that help the administrator to monitor APs and wireless network in real time.



## Create an Ultra-speed & Efficient Wi-Fi 6 Environment

PLANET IAP-2400AX Industrial 5GHz 802.11ax 2400Mbps Wireless Access Point supporting MU-MIMO, OFDMA, beamforming and BSS coloring provides a maximum wireless speed of 2400Mbps in the 5GHz band, ensuring a more secure and robust connectivity with the adoption of Wi-Fi 6 technology. It's ideal for the harsh environment as it can operate stably at temperatures from -40 to 75 degrees C. Its compact IP30 metal case allows either DIN-rail or wall mounting for efficient use of industrial space.



# Wireless AP Management Solution

PLANET Wireless AP Management Solution offers multiple ways of central AP management with Hardware AP Controller, Software AP Controller and Firmware AP Controller. The solution enables you to control up to 1,024,00 APs in different indoor or outdoor locations at the same time. Featuring the friendly floor plan, dashboard and graphical statistic functions through one single browser-based web user interface, the administrator can easily discover, configure, update and monitor all the managed APs.

## Hardware AP Controller

### UNC-NMS

Universal Network Management Central Controller with LCD

- Centrally manages up to 100 sites with up to 102,400 nodes spread all over
- Central provisioning and remotely controls over each managed device
- With encryption length of 2048 bits and SHA-265 algorithm for enhanced protection
- Physical site map viewing and logical topology view of network
- Alert popup message and e-mail alarm notification
- Top 10-site events, history comparison graph and critical event chart for analyzing network status



### NMS-500

Enterprise-class Universal Network Management Controller

- Auto discovery of up to 512 devices via web interface
- Central provisioning and remotely controls over each managed device
- A topology view of network devices by LLDP protocol
- SMTP alarm and syslog for managed devices in real-time status
- Smart AP Controller up to 512 APs
- Easy deployment with map positioning
- Dashboard and chart design for all information in one
- Console/Telnet command line interface
- Supports PLANET DDNS/Easy DDNS



### NMS-1000V-10

Universal Network Management Controller with LCD Touch Screen (10")

- Stylish TFT-LCD touch screen display and aluminum die-cast front bezel and chassis
- Auto discovery of up to 1024 devices via web interface
- Central provisioning and remotely control over each managed device
- A topology view of network devices by LLDP protocol
- All-new dashboard for monitoring traffic and PoE usage
- Setup Wizard, alert popup message and e-mail alarm notification
- Supports PLANET DDNS/Easy DDNS



### NMS-1000V-12

Universal Network Management Controller with LCD Touch Screen (12")

- Stylish TFT-LCD touch screen display and aluminum die-cast front bezel and chassis
- Auto discovery of up to 1024 devices via web interface
- Central provisioning and remotely control over each managed device
- A topology view of network devices by LLDP protocol
- All-new dashboard for monitoring traffic and PoE usage
- Setup Wizard, alert popup message and e-mail alarm notification
- Supports PLANET DDNS/Easy DDNS



### WS-1032P

Wireless AP Managed Switch with 8-Port 802.3at PoE

- AP discovery up to 32 managed APs
- Eight built-in 802.3at PoE+ ports to directly manage AP power control
- AP/PD alive check for operating status diagnostics
- 120-watt PoE budget
- 2 10G SFP+ uplink interfaces (2.5G Supported)-WS-1032P



# Hardware AP Controller

## VR-300 series

Enterprise 5-Port 10/100/1000T VPN Security Router

- Dual-WAN failover and load balancing
- Static Packet Inspection (SPI) firewall and blocks DoS/DDoS attack
- Full security with Cybersecurity, VLAN, NAT, DMZ, Static/Dynamic routing, and IP/MAC/Port filtering
- Multiple VPN with IPSEC, OpenVPN, PPTP, L2TP, GRE and VPN Failover
- PLANET UNI-NMS, Easy DDNS and Wireless AP Management
- Wi-Fi compliant IEEE 802.11b/g/n/ac/ax dual-band for mobile client connectivity (VR-300W6/VR-300W6A)
- Compliant with IEEE 802.3af/at PoE interface and PoE management (VR-300P)
- One 1000BASE-X SFP slot for WAN (VR-300F/VR-300FP/VR-300FW-NR)



## IVR-300 series

Industrial 5-Port 10/100/1000T VPN Security Gateway with Redundant Power

- Dual-WAN failover and load balancing
- Static Packet Inspection (SPI) firewall and blocks DoS/DDoS attack
- Full security with Cybersecurity, VLAN, NAT, DMZ, Static/Dynamic routing, and IP/MAC/Port filtering
- Multiple VPN with IPSEC, OpenVPN, PPTP, L2TP, GRE and VPN Failover
- PLANET UNI-NMS, Easy DDNS and Wireless AP Management
- Wi-Fi compliant IEEE 802.11b/g/n/ax dual-band for mobile client connectivity (IVR-300W)
- Compliant with IEEE 802.3af/at PoE interface and PoE management (IVR-300FP)
- -40 to 75 degrees C operating temperature and fanless design



## ICG-2515-NR

Industrial 5G NR Cellular Gateway with 5-Port 10/100/1000T

- Global 5G NR(NSA/SA)/4G LTE network with dual SIM design for cellular network redundancy
- 4 10/100/1000T LAN ports and 1 10/100/1000T WAN port
- 2 DI, 2 DO and 1 RS485 port for Modbus applications
- SSL VPN and robust hybrid VPN (IPSec/PPTP/L2TP over IPSec)
- Full security with VLAN, NAT, DMZ, routing, firewall and IP/MAC/port filtering
- PLANET NMS controller system and CloudViewerPro app supported
- DC 9 to 54V redundant power
- -40 to 75 degrees C operating temperature
- IP30 metal case with DIN-rail or wall-mount design



## ICG-2515W-NR

Industrial 5G NR Cellular Wireless Gateway with 5-Port 10/100/1000T

- Global 5G NR(NSA/SA)/4G LTE network with dual SIM design for cellular network redundancy
- Concurrent dual-band connectivity in 2.4GHz (600Mbps) and 5GHz (1200Mbps)
- 4 10/100/1000T LAN ports and 1 10/100/1000T WAN port
- 2 DI, 2 DO and 1 RS485 port for Modbus applications
- SSL VPN and robust hybrid VPN (IPSec/PPTP/L2TP over IPSec)
- Full security with VLAN, NAT, DMZ, routing, firewall and IP/MAC/port filtering
- PLANET NMS controller system and CloudViewerPro app supported
- DC 9 to 54V redundant power
- -40 to 75 degrees C operating temperature
- IP30 metal case with DIN-rail or wall-mount design



# Smart AP Control

AP Management Just Got Easier, More User-friendly & More Usable

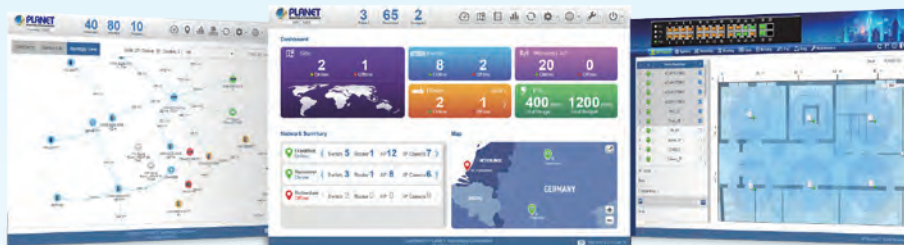

Topology

Dashboard

Floor Map



Color Touch LCD



Touch Panel



Simplified Cluster Management with 4 Steps

# Software AP Controller

## UNI-NMS-LITE

- AP auto-discovery
- Controls up to 100 APs
- Central provisioning and cluster management
- Easy deployment with map positioning
- Real-time AP status monitoring
- Profile creation and maintenance
- VM-based control, cross platforms
- Free license fee



# Enterprise Wi-Fi Networking Solution

PLANET enterprise PoE access points feature the latest 802.11ax wireless technology, advanced management functions and superior encryption standard yet cost-effectiveness. Meeting today's demand for advanced performance and security, PLANET enterprise PoE access points include multiple SSIDs, WPA/WPA2/WPA3, RADIUS MAC authentication and so forth. It is the perfect choice for homes, SOHOs, hotels, and offices to allow you to check e-mail and surf the Internet via the 2.4GHz band and simultaneously watch high-definition (HD) video or any other multimedia application via the 5GHz band.

## Enterprise Wireless Access Points/Industrial Wireless Access Points

### WDAP-C3000AX

Dual Band 802.11ax 3000Mbps Ceiling-mount Wireless Access Point w/802.3at PoE+ and 2 10/100/1000T LAN Ports

- Supports dual-band Wi-Fi 6 (802.11ax) with speeds up to 2400Mbps on 5GHz and 600Mbps on 2.4GHz
- Features MU-MIMO and OFDMA for efficient multi-user communication
- Seamless Roaming technology ensures smooth transitions between access points
- Beamforming enhances signal strength and stability, while BSS Coloring reduces interference
- Offers WPA3 security and supports WPA/WPA2/WPA3 and WPA2 Enterprise for robust protection
- Supports 802.11s Mesh technology for extended Wi-Fi coverage and stability



### WDAP-C7210E

1200Mbps 802.11ac Wave 2 MU-MIMO Dual Band Ceiling-mount Wireless AP

- Simultaneous dual-band connectivity at 2.4GHz 300Mbps and 5GHz 900Mbps
- Supports 11ac Wave 2 MU-MIMO and seamless roaming
- Supports IPv6 and port VLAN
- Supports captive portal and RADIUS server/client
- Multiple Operation Modes for various applications: Wireless AP, Repeater and Gateway Mode
- Centrally managed by PLANET NMS controller and PLANET CloudViewerPro app



### WDAP-W3000AX

Dual Band 802.11ax 3000Mbps In-wall Wireless Access Point

- Supports dual-band Wi-Fi 6 (802.11ax) with speeds up to 2400Mbps on 5GHz and 600Mbps on 2.4GHz
- Features MU-MIMO and OFDMA for efficient multi-user communication
- Supports standard 86 x 86 mm European outlet box
- Beamforming enhances signal strength and stability, while BSS Coloring reduces interference
- Offers WPA3 security and supports WPA/WPA2/WPA3 and WPA2 Enterprise for robust protection
- Supports 802.11s Mesh technology for extended Wi-Fi coverage and stability



### IAP-1800AX/IAP-2400AX

Industrial 5GHz 802.11ax 2400Mbps Wireless Access Point

- Simultaneous dual-band connectivity at 2.4GHz 600Mbps and 5GHz 1200Mbps (IAP-1800AX)
- 5GHz-band, 4T4R connectivity at 2400Mbps (IAP-2400AX)
- Supports MU-MIMO, OFDMA and seamless roaming, beamforming and BSS coloring
- Multiple operation modes: AP, repeater, gateway and WISP mode options
- Supports Wi-Fi MESH
- Centrally managed by PLANET NMS controller and PLANET CloudViewerPro app
- Effective fault alarm and DI/DO alert for better protection





# Outdoor Wireless LAN Solutions

## WISP Solution

Compared with the traditional ISP provider that offers wired Internet service, PLANET WISP solution provides more elastic, more effective and low-cost wireless Internet service, and no limitation of place, be it a small residence or campus.

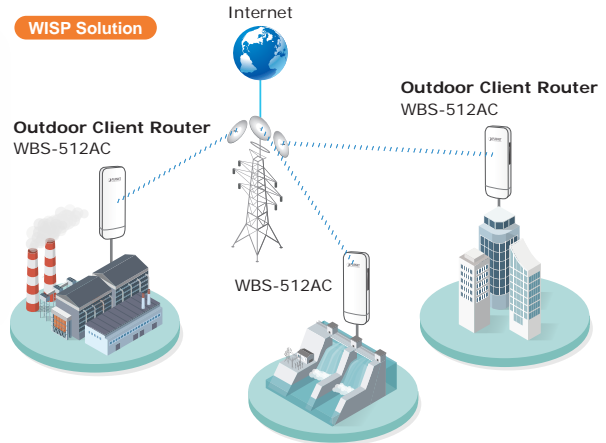

## Wi-Fi Solution

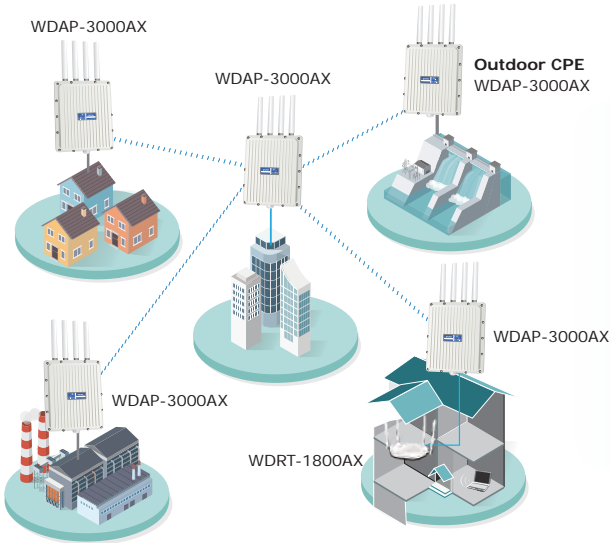

## Outdoor Wi-Fi Mesh Solution

It provides small and medium businesses or SOHO with wireless Mesh data transmission solution. It features a wireless point to point/multiple point to multiple point bridge, general data transmission and media transmission like surveillance monitoring between buildings. It is suitable for wide-ranging connectivities.

## Outdoor CPE/Client

PLANET Outdoor Wireless Solution supports multiple wireless communication connectivities (AP, Client CPE, WDS PtP, WDS PtMP, Repeater, Universal Repeater and WISP) suitable for various application requirements and thus it helps users to easily build a wireless network and extend the wireless range of the existing wireless network.

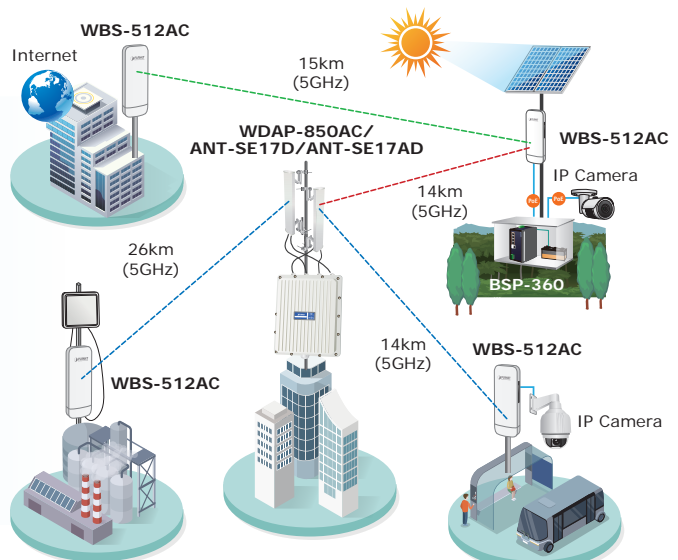



## 5GHz and 2.4GHz 802.11ax/ac Wireless Outdoor Solutions

PLANET Outdoor Wireless Solution provides higher transmission power, longer distance, and better performance than standard outdoor wireless access points. It is equipped with various antennas and multiple adjustable transmission output power controllers which are quite suitable for longer distance and widely open space applications.

### Wireless Outdoor CPEs

#### WDAP-3000AX

Dual Band 802.11ax 3000Mbps Outdoor Wireless AP

- Supports Wi-Fi Mesh wireless network with Wizard
- Simultaneous dual-band connectivity in 2.4GHz (600Mbps) and 5GHz (2400Mbps)
- Supports MU-MIMO, OFDMA and seamless roaming
- 20KV surge protection for wired cable interface
- Supports IP67 rating, operating in temperature ranging from -40 to 70 degrees C
- Centrally managed by PLANET NMS controller and PLANET CloudViewerPro app

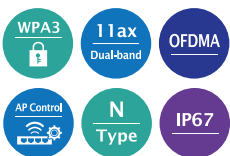

#### WDAP-850AC

1200Mbps 802.11ac Wave 2 MU-MIMO Dual Band Outdoor AP

- Simultaneous 2.4GHz (Wi-Fi access) and 5GHz (backhaul) wireless network
- Gigabit wire and Wave 2 1200Mbps wireless connectivity (dual-band)
- 4 built-in N-type (F) antenna connectors
- 802.1Q VLAN mapping multiple SSIDs
- Ground terminal design
- 802.3at Power over Ethernet
- Centrally managed by PLANET AP Controller Series (NMS Series, WS Series, VR-300 & IVR-300 Series)



#### WBS-512AC

5GHz 802.11ac 900Mbps Outdoor Wireless CPE

- 5GHz 11ac Wi-Fi speed up to 900Mbps Wave 2.0, MU-MIMO
- Built-in 14dBi directional antenna for PtP connection
- Multiple operation modes: AP, Gateway, Repeater, WDS, WISP
- Supports multiple VLANs mapping to multiple SSIDs
- "One-click PtP" to establish connection easily
- Centrally managed by PLANET AP Controller Series (NMS Series, WS Series, VR-300 & IVR-300 Series)



#### WBS-900AC

5GHz 802.11ac 900Mbps TDMA Outdoor Long Range Wireless CPE

- Equipped with advanced TDMA, ATPC, and MU-MIMO Wave 2 technologies
- Seamless design
- 25dBi dual-polarization antenna for PtP connection spanning up to 15km
- IP65-rated UV-resistant enclosure for harsh environment
- Built-in TVS lightning protection



# 5G NR/4G LTE Cellular Wireless Gateways

## ICG-2515-NR/ICG-2515F-NR

Industrial 5G NR Cellular Gateway with 5-Port 10/100/1000T

- Global 5G NR(NSA/SA)/4G LTE network with dual SIM design for cellular network redundancy
- 4 10/100/1000T LAN ports and 1 10/100/1000T WAN port
- 2 DI, 2 DO and 1 RS485 port for Modbus applications
- SSL VPN and robust hybrid VPN (IPSec/PPTP/L2TP over IPSec)
- Full security with VLAN, NAT, DMZ, routing, firewall and IP/MAC/port filtering
- PLANET NMS controller system and CloudViewer app supported
- DC 9 to 54V redundant power
- -40 to 75 degrees C operating temperature
- IP30 metal case with DIN-rail or wall-mount design
- 1 1000 BASE-X SFP Slot for WAN/LAN interface (ICG-2515F-NR)



## ICG-2515W-NR/ICG-2515FW-NR

Industrial 5G NR Cellular Wireless Gateway with 5-Port 10/100/1000T

- Global 5G NR(NSA/SA)/4G LTE network with dual SIM design for cellular network redundancy
- 4 10/100/1000T LAN ports and 1 10/100/1000T WAN port
- 2 DI, 2 DO and 1 RS485 port for Modbus applications
- SSL VPN and robust hybrid VPN (IPSec/PPTP/L2TP over IPSec)
- Full security with VLAN, NAT, DMZ, routing, firewall and IP/MAC/port filtering
- PLANET NMS controller system and CloudViewer app supported
- DC 9 to 54V redundant power
- -40 to 75 degrees C operating temperature
- IP30 metal case with DIN-rail or wall-mount design
- 1 1000 BASE-X SFP Slot for WAN/LAN interface (ICG-2515FW-NR)



## ICG-2210W-NR

Industrial 5G NR Compact Cellular Wireless Gateway with 2-Port 10/100/1000T

- 5G NR (NSA/SA)/4G LTE network with dual SIM design for cellular network redundancy
- 2 Micro SIM slots for cellular network connection
- 1 10/100/1000BASE-T LAN port and 1 10/100/1000BASE-T WAN/LAN port
- Supports 802.11b/a/g/n/ac for connectivity on mobile clients
- SSL VPN and robust hybrid VPN (IPSec/PPTP/L2TP over IPSec)
- 1 RS485 2-pin and 1 RS232 3-pin interface
- A compact, DIN-rail-mountable IP30 metal case.
- DC 9 to 36 V power input
- -40 to 75 degrees C operating temperature



## VR-300FW-NR

5G NR Cellular + Wi-Fi 6 AX 1800 Dual Band + 1-Port 1000X SFP VPN Security Router

- Global 5G NR (NSA/SA)/4G LTE network with SIM design for cellular network redundancy
- Automatic failover between 5G NR and Gigabit WAN
- Complies with IEEE 802.11ax and IEEE 802.11a/b/g/n/ac standards
- Dual-WAN failover and dual-WAN load balancing
- 1 1000BASE-X SFP slot for WAN interface
- SSL VPN and robust hybrid VPN (IPSec/PPTP/L2TP over IPSec)
- Stateful Packet Inspection (SPI) firewall and content filtering
- Blocks DoS/DDOS attack, port range forwarding
- High Availability, AP Controller, Captive Portal and RADIUS
- IPv6, SNMP, PLANET DDNS and Universal Network Management System
- Planet NMS controller system and CloudViewerPro app supported



## FWA-2100-NR

Industrial 5G NR Outdoor Unit (ODU) with 1-port Gigabit PoE PD

- 5G NR (NSA/SA)/4G LTE network with dual SIM design for cellular network redundancy
- 2 Nano SIM slots for cellular network connection
- 1 10/100/1000BASE-T LAN port
- SSL VPN and robust hybrid VPN (IPSec/PPTP/L2TP over IPSec)
- Blocks DoS/DDOS attack, port range forwarding
- High Availability, AP Controller, Captive Portal and RADIUS
- PLANET NMS controller system and CloudViewerPro app supported
- DC 12V or 802.3at PoE+ input
- IP68 rating
- -20 to 60 degrees C operating temperature



## VCG-1500WG-LTE

Vehicle 4G LTE Cellular Wireless Gateway with 5-Port 10/100TX

- 4 10/100TX LAN ports and 1 10/100TX WAN port
- Industrial power with wide DC voltage power supply design
- One SIM slot and one 4G LTE antenna for network connection
- Supports Wi-Fi 802.11 b/g/n for connectivity on mobile clients
- GPS antenna allows to detect the location via sat nav system
- Supports GRE, PPTP, IPSec and L2TP
- Supports NAT, DMZ, MAC/Application/IP filter and static routing
- Supports DHCP server/client, PPPoE, static IP and DDNS
- -25 to 65 degrees C operating temperature
- Supports CMS and SNMP for remote management



# 5G NR/4G LTE Cellular Wireless Gateways

## ICG-2510W-LTE/ICG-2510WG-LTE

Industrial 4G LTE Cellular Wireless Gateway with 5-Port 10/100/1000T

- 5-port Gigabit Ethernet, built in redundancy protocol-VRRP
- 2 DI/DO and 1 serial port (RS232 or RS485) for Modbus applications
- Dual module SIM for network load balancing and redundancy
- WiFi compliance IEEE 802.11b/g/n/ac dual-band for mobile client connectivity
- GPS antenna allows to detect the location via sat nav system (ICG-2510WG-LTE)
- Multiple VPN with IPSEC, OpenVPN, PPTP, L2TP, GRE and VPN Failover
- Full security with VLAN, NAT,DMZ, Static routing, Firewall and IP/MAC/Port filtering
- Supports CMS for remote management
- -35 to 70 degrees C operating temperature and fanless design



## Wireless Antennas and Cable Accessories

To commit the wireless long-distance connectivity, PLANET Wireless LAN Solution also provides a variety of Antennas, Cables and other Accessories for 2.4GHz and 5GHz band applications where more RF gain power is required to increase the convergence of the installations wirelessly.

The antennas include unidirectional antenna and omni-directional antenna to meet the need of different environments. The omni-directional antenna is ideal to install in a central base-station in a point to multi-point wireless application, and unidirectional antennas are designed for long distance.

To keep the wireless device free from lightning induced surges that travel on the coaxial transmission lines, PLANET also provides the arrester guarding the wireless equipment from damage that could cause your previous network resources to break down.

### Flat Panel Antennas



#### ANT-FP14AD

14dBi Flat Panel Dual Polarization Antenna



#### ANT-FP18A

18dBi Flat Panel Antenna



#### ANT-FP14D

14dBi Flat Panel Dual Polarization Antenna



#### ANT-FP18

18dBi Flat Panel Directional Antenna

### Omni-directional Antennas



#### ANT-OM8

8dBi Omni-directional Antenna



#### ANT-OM15

15dBi Omni-directional Antenna



#### ANT-OM5D-KIT

Dual Band Omni-directional Antenna 4/7dBi



#### ANT-OM10A

10dBi Omni-directional Antenna

### Cables & Others



#### WL-LTNA

2.4/5GHz Lightning Arrester  
(N-male to N-female)



#### WL-NM-0.6

0.6m N-male (male pin) to N-male  
(male pin) Cable

### Sector Antennas



#### ANT-SE17AD

2x2 MIMO 5GHz 17dBi Sector Antenna

# Plug-and-Play Recorder

that Requires Minimum Configuration  
and Allows the Fastest Deployment



**H.265 16-ch 4K  
Network Video Recorder**

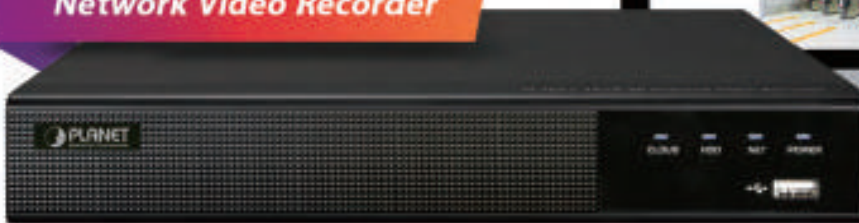

**NVR-1600**



**Dual Light**



## ICA-M3580P

H.265+ 5 MP Full Color Smart IR Bullet IP Camera with Remote Focus and Zoom

- 1/2.8" 5 megapixel SONY STARVIS back-illuminated CMOS sensor with progressive scan
- Simultaneous H.264(+)/H.265(+)/JPEG multi-stream video encoding
- Supports Full Color (White LED) and Smart IR (IR LED) in one
- IP67-rated metal housing with cable management bracket for rigorous environment
- Supports IPv6, QoS, IEEE 802.1X network functions and TLS for secure email security and encryption
- NDAA compliant

## NVR-1600

H.265+ 16-ch 4K Network Video Recorder

- Supports H.264/H.265/H.264+/H.265+ compression with up to 4K (3840 x 2160) video resolution
- Scheduled recording of 16 IP cameras simultaneously
- Supports operation simultaneously for Preview, Recording, Playback, Live and Backup
- Multiple event detections like motion detection, video loss and PLANET AI IP camera event management
- Smart event detection like Line Crossing, Regional Intrusion, Loitering, and People Gathering
- Mobile phone app/PLANET PVMS software for easy configuration and expandable multi-sites management of up to 256-ch IP cameras simultaneously

# IP Surveillance

## High Frame Rate (60fps) for Real-time Surveillance Applications

PLANET Exmor IP Camera Series with Zero-lux Illuminator is a high-resolution camera for the round-the-clock surveillance over IP networks. It supports H.264 and MJPEG compression formats and delivers excellent picture quality in Full HD resolutions at 60 frames per second (fps). Incorporating the new Exmor RSTM CMOS image sensor, it provides high-quality images under all lighting conditions.



## Full Surveillance with 180° Panoramic Surround View

PLANET Fisheye IP Camera Series allows you to monitor all angles of a location using just one camera. Without installing any software, you can watch live view and utilize functions such as motion detection and camera tampering through the Web interface using a web browser. Distortion correction feature of the ICA-W8100 can fix the camera video so you can use e-PTZ to zoom in, zoom out, and pan across your camera's video to survey a large area easily.

## Efficient Remote Monitoring of IP Cameras

PLANET IP Surveillance Solution provides multiple ways for users to remotely monitor all IP cameras more efficiently, such as user-friendly website management, apps for smart-phones and pads, and free DDNS services. It is quick to easily access your PLANET IP surveillance camera over both mobile phone and Wi-Fi network anytime, anywhere.



## Cloud Services Make Access Easy Anywhere

To make home monitoring a truly simple experience, we have created Cloud App to enable you to access live video feeds of your home or office from any Internet-connected computer, iPhone®, iPad®, or Android® device anytime, anywhere. The Cloud Cameras can be viewed and managed on your personal account via Cloud App to enable you to enjoy the freedom of remote monitoring on your terms.

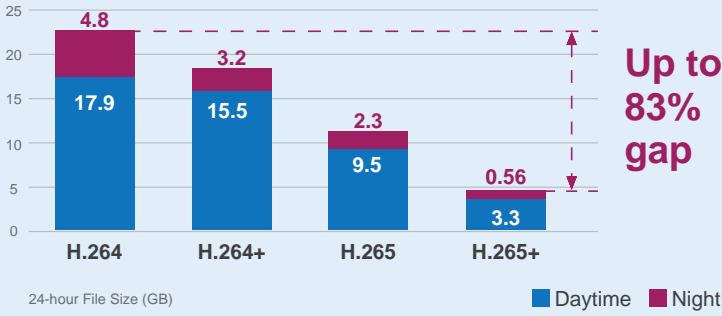

## H.265+ Surveillance

PLANET H.265+ Series of IP Cameras can perform in various surveillance applications. With high-resolution design, it can capture clear images and is perfect for identifying objects and persons. Moreover, it supports 802.3af PoE interface, and facilitates the indoor surveillance applications without worrying the electric source. Besides, NVR and Web UI management make it easy to do the configuration and live viewing. With so many features offered, PLANET H.265+ Series of IP Cameras no doubt is your best choice for indoor surveillance solution.

### ICA-3480

- 1/3" Progressive Scan CMOS Sensor and 25-meter Smart IR illuminators
- H.264(+)/H.265(+)/MJPEG/AVI multi-stream video encoding
- Supports 5 backlight compensation (BLC) modes: Left, Right, Up, Down, Middle
- Supports digital WDR (DWDR) and 3-dimensional Noise Reduction (3DNR)
- Supports IPv6, QoS, IEEE 802.1X network functions and TLS for secure email security and encryption
- IP67-rated metal housing with cable management bracket for rigorous environment



H.265+  
H.264+  
4  
Megapixel  
Outdoor

### ICA-4480

- Equipped with a 1/3" Progressive Scan CMOS Sensor and 25-meter Smart IR illuminators for simultaneous image capture.
- Offers multi-stream video encoding in formats such as H.264(+)/H.265(+)/MJPEG/AVI.
- Provides support for 5 backlight compensation (BLC) modes: Left, Right, Up, Down, Middle.
- Features digital WDR (DWDR) and 3-dimensional Noise Reduction (3DNR) for improved image quality.
- Supports IPv6, QoS, IEEE 802.1X network functions, and TLS for secure email communication and encryption.
- Designed with an IP67-rated metal housing and cable management bracket to withstand harsh environments.



H.265+  
H.264+  
4  
Megapixel  
Outdoor

### ICA-4480F

- Full Color Dome type with 1/3" progressive scan CMOS sensor
- H.265+/H.265/H.264+/H.264 compression
- Supports 5 backlight compensation (BLC) modes: Left, Right, Up, Down, Middle
- 4000K warm white LED with maximum illumination distance of up to 25 meters
- Supports digital wide dynamic range (DWDR)
- IP67-rated metal housing with cable management



H.265+  
H.264+  
4  
Megapixel  
Full Color

### ICA-M3580P

- 1/2.8" 5 megapixel SONY STARVIS back-illuminated CMOS sensor with progressive scan
- Simultaneous H.264(+)/H.265(+)/JPEG multi-stream video encoding
- Supports Full Color (White LED) and Smart IR (IR LED) in one
- IP67-rated metal housing with cable management bracket for rigorous environment
- Supports IPv6, QoS, IEEE 802.1X network functions and TLS for secure email security and encryption
- NDAA compliant



H.265+  
H.264+  
5MP  
Outdoor

Dual Light

## ICA-M4580P

- 1/2.8" 5 megapixel SONY STARVIS back-illuminated CMOS sensor with progressive scan
- Simultaneous H.264(+)/H.265(+)/JPEG multi-stream video encoding
- Supports Full Color (White LED) and Smart IR (IR LED) in one
- IP67-rated metal housing with cable management bracket for rigorous environment
- Supports IPv6, QoS, IEEE 802.1X network functions and TLS for secure email security and encryption
- NDAA compliant



Dual Light

## ICA-3880

- 1/2.8" 8 megapixel SONY Starvis Back-illuminated CMOS sensor and built-in MIC
- H.264(+)/H.265(+)/JPEG multi-stream video encoding
- Supports Full Color (White LED) and Smart IR (IR LED) in one
- Supports digital WDR (DWDR) and 3-dimensional noise reduction (3DNR)
- Supports IPv6, QoS, IEEE 802.1X network functions and TLS for secure email security and encryption
- NDAA compliant



Dual Light

## ICA-4880

- 1/2.8" 8 megapixel SONY Starvis Back-illuminated CMOS sensor and built-in MIC
- H.264(+)/H.265(+)/JPEG multi-stream video encoding
- Supports Full Color (White LED) and Smart IR (IR LED) in one
- Supports digital WDR (DWDR) and 3-dimensional noise reduction (3DNR)
- Supports IPv6, QoS, IEEE 802.1X network functions and TLS for secure email security and encryption
- NDAA compliant



Dual Light

# H.265+ Network Video Recorders

## NVR-1600

- Supports H.264/H.265/H.264+/H.265+ compression with up to 4K (3840 x 2160) video resolution
- Scheduled recording of 16 IP cameras simultaneously
- Supports operation simultaneously for Preview, Recording, Playback, Live and Backup
- Multiple event detections like motion detection, video loss and PLANET AI IP camera event management
- Smart event detection like Line Crossing, Regional Intrusion, Loitering, and People Gathering
- Mobile phone app/PLANET PVMS software for easy configuration and expandable multi-sites management of up to 256-ch IP cameras simultaneously



Smart Event Detection | PLANET DDNS | Cloud | H265+ | Dual Monitor Display | 4K Ultra HD

Intelligent Alarm & Recording

- Line Crossing
- Intrusion Detection
- Loitering Detection
- People Gathering Detection

Bandwidth Savings

H.264+ | H.265 | H.264

Control Management System Up to 256 Channels



# H.264 IP Cameras

PLANET H.264 Series of IP Cameras supports M-JPEG compression formats to deliver excellent picture quality in various surveillance applications. It can provide the identification of objects and people, perfect for surveillance needs from all aspects for most outdoor and indoor environments such as railway stations, warehouses, airports, construction sites, homes, boutiques, department stores, restaurants and more.

## ICA-HM620

- Sony Exmor progressive CMOS sensor
- 4.7~94mm vari-focal, auto-iris lens
- 20X optical, 8X digital zoom
- Maximum resolution 1920 x 1080 (30fps)/1280 x 720 (60fps)
- WDR, 3DNR, IP66, PoE+



## Fisheye IP Camera

### ICA-W8100

- 0.89mm fisheye lens
- Maximum resolution 1280 x 720 (30fps)
- IEEE 802.11n wireless LAN compliant
- WPS, PIR for thermal, motion detection



## Pan & Tilt IP Camera

### ICA-W7100

- 3.6mm board lens
- Maximum resolution 1280 x 720 (30fps)
- 10-meter IR LEDs with ICR
- WDR, 2DNR
- Pan and tilt (Pan: 0°~355°; Tilt: 0°~90°)
- IEEE 802.11n wireless LAN compliant



# Network Video Recorders

To save the total cost of ownership (TCO), PLANET provides the alternative way to store all the videos and audios from the IP camera and the NVR. The NVR product family includes 8-ch, 25-ch and 64-ch capability that can record IP cameras that are connected on the IP network whether they are wired or wireless and indoors or outdoors.

- Simultaneous recording and live video streams
- Supports MJPEG, MPEG-4 H.264 and H.265 compressions
- Mobile devices remote monitoring
- Auto configuration for PLANET IP camera
- Easy access with PLANET Dynamic DNS
- Manual or schedule recording of 8/25/64 IP cameras simultaneously
- ONVIF compliant

- Video recycling function keeps the video recording 24/7
- Web-based and management utility for easy configuration
- 2-way audio function
- E-Map interface in web and utility configuration
- Exports recorded video file to AVI format
- Multiple Languages support

## NVR-1600

- Supports H.264/H.265/H.264+/H.265+ compression with up to 4K (3840 x 2160) video resolution
- Scheduled recording of 16 IP cameras simultaneously
- Supports operation simultaneously for Preview, Recording, Playback, Live and Backup
- Multiple event detections like motion detection, video loss and PLANET AI IP camera event management
- Smart event detection like Line Crossing, Regional Intrusion, Loitering, and People Gathering
- Mobile phone app/PLANET PVMS software for easy configuration and expandable multi-sites management of up to 256-ch IP cameras simultaneously



## NVR-820

- Records 240fps @1920 x 1080
- Maximum bitrate 55Mbps
- 2 x SATA HDD
- HDMI and VGA dual local display
- Intelligent, Google e-Map, and multi-brand IP CAM support





## Windows-based NVR

### NVR-E6480

- Manages up to 64 cameras
- 8-bay rackmount (2U) with software RAID (0,1)
- Instant playback in live view window
- Location management with eMap
- Supports dual stream management
- Remote access via mobile app, Web browser or CMS



## Hybrid Digital Video Recorders

- Embedded, highly-reliable standalone HDVR
- Supports hybrid mode for combination of IP, AHD and analog cameras
- Supports H.264/H.265 compression
- Supports RS485 for PTZ control
- 2-way audio support with enhanced audio quality
- Video recycling function records events 24/7
- ONVIF compliant for interoperability
- Up to 256 channels with the central management software
- Supports two USB2.0 ports for mouse control and backup
- Supports mobile phone remote viewer, Web UI and CMS

### HDVR-435

- 5-in-1 – TVI, CVI, AHD, CVBS and IP Full HD video input
- 4-ch BNC connectors and 1 SATA HDD
- 1080p encoding for analog mode
- H.265 high profile video compression
- HDMI and VGA output at 1920 x 1080 resolution
- ONVIF compliant for interoperability
- Multiple-language graphic OSD
- CMS and mobile app for remote monitoring



## AHD Cameras

### CAM-AHD425

Product Image



Sony Sensor 4-in-1

Resolution	AHD 1080p
Sensitivity	0 lux with built-in IR LED
Sensor	1/2.8" Sony CMOS sensor
Lens	3.6mm/F1.2
IR Distance	20 meters
WDR	D-WDR
Day and Night	IRC switch
Digital Noise Reduction	2DNR/3DNR
Protection Class	IP65

# Integrated HD VoIP Solution for Businesses and Homes



- Easy integration with IETF SIP Protocol
- Asterisk-based IP PBX

- User-friendly Color IP Phone
- IP-based Video Intercom



**SIP IP Intercoms**



**Indoor Touch Screen PoE Video Intercom**



**SIP HD Color PoE IP Phone**

# IP Telephony

## HD Voice

PLANET VoIP Series features wide-band, high-definition voice for crisp, precise sound quality whether delivered via the handset, speakerphone or optional headset. All phones in the series feature wideband-compliant, and hearing aid compatible handsets along with built-in, high-quality speakers and microphones.



## Conferencing Solutions

The convenient 3-way conferencing feature, available on all PLANET VoIP Series, will help you save time and resources. A paging function lets you quickly get two colleagues on the phone with you for a conference even if they're located at the opposite ends of the country.

## Watching Live Surveillance Images via SIP IP Cameras

PLANET SIP communication solution integrated with IP PBX, IP phone and IP camera helps users to watch live surveillance view more easily just by dialing a phone number. With the motion alarm function, the SIP IP camera provides a more instant, efficient response method, better than the other methods, such as FTP, email, SD card and more, to alert users so as to prevent a bad event from happening.



IP PBX

## Green IP Office

The Fax to Email/Email to Fax service by PLANET IP PBX allows users to transfer/receive faxes directly to/from your email inbox as file attachments. It's an easy and confidential way of receiving, storing and forwarding important fax documents, thus creating a paperless green office.



## Managing your Office from your Mobile Device

Users have an IP PBX phone number including an office extension number where calls ring simultaneously on their mobile device, making it easy to connect one another wherever they are. Access to people, messages and information help mobile users deliver whether they are in or out of the office.

# SIP IP Conference Phones

PLANET Professional VIP Telephone series is both aesthetically appealing and highly practical, meeting whatever business requirements you need for your daily work. Advanced business telephony features, including wideband HD audio for crystal-clear conversation, HD displays and support for security standards such as TLS and SRTP, are indispensable when it comes to quality and functionality. These high-performance devices are future proofed and provide the best in wideband HD audio, ensuring crystal-clear sound quality in the on-premise or hosted PBX environment.

- IETE SIP (RFC 3261), STUN (RFC 3489)
- Power over Ethernet IEEE 802.3af/at
- Auto provisioning, TR069, VPN, VLAN, QoS
- Advanced security protection with SRTP/TLS/HTTPS
- Interoperable with all major IP PBX platforms
- Acoustic echo cancellation (AEC), adaptive jitter buffer (AJB)
- Background noise estimation (BNE)
- Comfort noise generation (CNG), noise reduction (NR)
- Packet loss concealment (PLC), voice activity detection (VAD)
- Audio codecs: G.711 A-law,  $\mu$ -law, G.722 (wideband), G.723, G.726 and G.729AB

## VIP-1260PT

- IETE SIP compliant with Transport Layer Security
- Wideband G.722 HD and Opus audio
- 2.8-inch color LCD with Multi-language display
- Dual Gigabit and IEEE 802.3af/at PoE compliant



## VIP-1140PT

- IETE SIP compliant with Transport Layer Security
- 4 SIP Lines
- 6-way Audio Conference
- Wideband G.722 HD and Opus audio
- 2.4-inch color LCD with Multi-language display



## ICF-2000

- 7-inch color touch screen with Android 9.0 OS.
- Built-in 5MP camera with 1080p @ 30fps H.264 video call support.
- Up to 20 SIP lines with 112 one-touch DSS keys.
- Dual Gigabit and IEEE 802.3af/at PoE compliant.
- Built-in 2.4GHz/5GHz dual-band Wi-Fi.
- Supports up to 3-party video/audio mixed conferencing and 10-party audio conferencing.
- Wideband G.722 HD and Opus audio codec with handset and hands-free function.



## VTS-700WP

- Stylish 7-inch 1024 x 600 resolution IP Intercom touch screen display
- Powered by PoE or external source
- 8-zone alarm interface available for security control
- Short Circuit Output x 1/Short Circuit Input x 1/RS-485 x 1
- Built-in Wi-Fi 2.4G/5G
- Standard SIP protocol compatible with modern IP Intercom systems
- Integrates control gateway and door phone with one control pad
- Real-time image (1080P) monitoring of home and community public cameras



## PLANET IP Phone Enables Seamless Communication from Meetings to Front Desk

**20 SIP Conference Phone**

**HD Audio**

**Dual-band Wi-Fi**

**Power over Ethernet**

**Video Conferencing**

**Desk or Wall Mounting**

# SIP Intercom & Door Phones

PLANET SIP Door Phone series is the ideal solution for communication in general-purpose outdoor and indoor environments. Its sleek and fast-to-install features are combined with advanced technology. It provides visitor communication monitoring and access control. One glance at the display panel will let you know who is standing outside your door. Then, you start a dialogue or open the door lock. In addition, with PLANET IP PBX or Z-Wave Plus Gateway, you can obtain a comprehensive system for door communication or easy integration into an existing home automation system.

- IETE SIP (RFC 3261), STUN (RFC 3489)
- Power over Ethernet IEEE 802.3af/at
- ONVIF compliant for interoperability
- Auto provisioning, TR069, VPN, VLAN, QoS
- Advanced security protection with SRTP/TLS/HTTPS
- Interoperable with all major IP PBX platforms
- AEC, AJB, BNE, CNG, NR, PLC, VAD
- Audio codecs: G.711 A-law,  $\mu$ -law, G.722 (wideband), G.723, G.726 and G.729AB

## HDP-1261PT

- With high protection level of IP66 and IK07, wide temperature range from -40° to 70°
- Support to open the door with RFID/IC cards, NFC, indoor switch, remote DTMF/Timed open door
- Built in 2M pixels wide-angle camera: 120°(H), 60°(V) with infrared night-vision feature
- Compatible with SIP and ONVIF protocols
- Built-in maximum 128GB capacity TF card slot for image storage
- HD voice speech quality with built-in 2.5W speaker and Acoustic Echo Canceller



## HDP-5260PT

- 720p HD camera with 3 IR LEDs
- Wideband G.722 HD audio
- Anti-vandal solution
- IP65 and IK10 for rigorous environment
- -40 to 70 degrees C operating temperature
- Unlock the door with an RFID, remote DTMF or local password



# IP PBXs

Small and medium businesses require specialized features to support their workflows. PLANET IP PBX is designed specifically for small and medium businesses. It combines an IP PBX with robust telephony features that traditional phone systems can't deliver. PLANET IP PBX is affordable, reliable, full-featured, and easy to deploy, administer, and maintain. It helps small and medium businesses dramatically reduce communications and network management costs, enhance collaboration, improve productivity, and more.

- IETE SIP (RFC 3261), STUN (RFC 3489)
- Automatic recording/One touch recording
- Multi-language, CDR and multi-layer IVR
- Intercom, paging and video call
- Call forward, follow me and DND
- Ring/pick-up groups, and smart DID
- Virtual fax, voicemail to email and fax to email
- Auto provisioning, TR069, VPN, VLAN
- Advanced security protection with SRTP/TLS/HTTPS
- Audio codecs: G.711 A-law,  $\mu$ -law, G.722 (wideband), G.726, G.729, GSM, Speex, Opus

## IPX-1100

- 50 concurrent calls and up to 100 registers
- 30 conference room calls
- Recording/Voicemail up to 400 hours



## IPX-1102

- 50 concurrent calls and up to 100 registers
- 30 conference room calls
- Recording/Voicemail up to 400 hours
- Built-in 2 FXO interfaces



## IPX-2200

- 80 concurrent calls and up to 200 registers
- 60 conference room calls
- Recording/Voicemail up to 15,000 hours
- 2 slots for maximum 8 ports for FXO/GSM
- 10/100/1000 Gigabit Ethernet



## IP PBXs

### IPX-21SL/IPX-21FO

- 4 standard two-wire, RJ11 interfaces
- Up to 4 ports for 4 POTS lines (IPX-21FO)
- Up to 4 ports for 2 POTS lines and 2 FXS connect to analog phone set (IPX-21SL)
- Loop start signaling for advanced features: caller ID and distinctive ring



For IPX-2500 / IPX-2200 / IPX-2100

### IPX-21GS

- Quad-band EGSM 850/900/1800/1900 MHz for worldwide GSM compatibility and deployments
- Up to 4 ports for 4 GSM lines
- GSM protocol stack for voice and SMS
- Loop start signaling for advanced features: caller ID and distinctive ring



For IPX-2500 / IPX-2200 / IPX-2100

## SIP VoIP Gateway

PLANET VGW series is easy to use for all types of businesses. The VoIP Gateway offers quality voice communications and real-time fax data over IP networks and it does not need human resources to deploy a VoIP network. With the optimized SIP architecture, VoIP Gateway provides added flexibility during migration to Unified Communications by supporting the traditional analog devices.

PLANET VoIP Gateway is the ideal choice for P2P/SIP proxy (IP PBX) voice chat, and ITSP cost-saving solution.

### VGW-420FS

- 4-line FXS connects to analog phone set or PABX



### VGW-820FS

- 8-line FXS connects to analog phone set or PABX



### VGW-1620FS

- 16-line FXS connects to analog phone set or PABX



### VGW-2420FS

- 24-line FXS connects to analog phone set or PABX



### VGW-3220FS

- 32-line FXS connects to analog phone set or PABX



### VGW-420FO

- 4-line FXO connects to analog phone line or IP PBX



## Skype Gateway

### SKG-300

- Auto detection and switching of incoming PSTN or Skype calls
- Three-way conferencing between PSTN and Skype calls
- PSTN call forward to Skype or Skype call forward to PSTN
- Support call waiting and full-duplex and echo-free sound quality



## Wireless SIP Router/DECT Phone

### VIP-462DG

- Complies with IETE SIP (RFC 3261), and ETSI DECT
- Complies with IEEE 802.11b/g standards
- 2 identities/accounts with 1 FXS and 1 DECT handset
- PSTN lifeline for emergency calls
- SPI firewall and DoS protection
- QoS, VAD, CNG and dynamic jitter buffer
- Audio codecs: G.711 A-law,  $\mu$ -law, G.723.1 and G.729



# Building a Safe and Secure Network Powerful Enterprise VPN Security Solution



**Enterprise 5-Port 10/100/1000T  
VPN Security Router**  
VR-100/VR-300/VR-300FW-NR



**Cyber Security**



**Content Filtering**



**SPI Firewall**



**VPN Encryption**

## Excellent Ability in Threat Defense

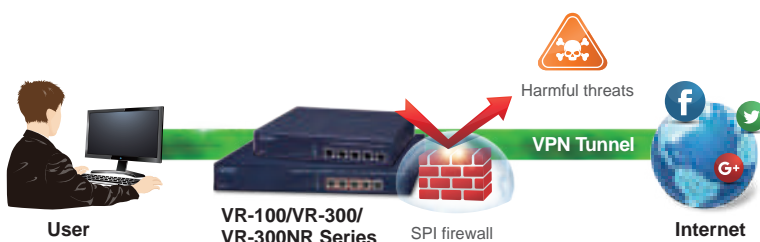

## Load Balancing

Balance network traffic across the WAN ports.



## Dual WAN ports

2 WAN ports for failover, offering non-stop network connectivity.



# VPN Security Routers / Industrial VPN Security Gateway Series

PLANET has launched Wireless VPN Security Router Series and Industrial 5G NR Cellular Gateway that includes the cutting-edge 5G technology, Wi-Fi 6, and an array of security features, such as cybersecurity, SPI firewall, and policy auditing encompassing content filtering, VPN tunnel, and MAC/IP filtering. This integration aims to empower users in deploying networks with improved transmission performance and heightened security measures.

PLANET VR-300F series, IVR-300F and ICG-2515F series offer versatile connectivity options, providing copper and fiber connectors for the WAN interface. Equipped with an SFP slot, these devices extend connectivity distances from 550 meters to 2 kilometers (for multi-mode fiber) and 10 to 120 kilometers (single-mode fiber or WDM fiber). Additionally, they support the SFP-DDM (digital diagnostic monitor) function, enabling easy real-time monitoring of critical parameters such as optical output power, optical input power, temperature, laser bias current, and transceiver supply voltage.

## VR-300 Series

- Dual-WAN failover and load balancing
- SSL VPN and robust hybrid VPN (IPSec/PPTP/L2TP over IPSec)
- Stateful Packet Inspection (SPI) firewall and content filtering
- Blocks DoS/DDOS attack, port range forwarding
- High Availability, AP Controller, Captive Portal and RADIUS
- Compliant with the IEEE 802.3at PoE+ with PD alive check and schedule management
- PLANET Universal Network Management System and CloudViewer app supported



## VR-100

- Dual-WAN failover and load balancing
- Static Packet Inspection (SPI) firewall and blocks DoS/DDoS attack
- Full security with cybersecurity, VLAN, NAT, DMZ, static/dynamic routing, and IP/MAC/port filtering
- Multiple VPN with IPSEC, OpenVPN, PPTP, L2TP, GRE and VPN failover
- IPv6, PLANET UNI-NMS, easy DDNS
- PLANET Universal Network Management System and CloudViewer app supported



## IVR-300/IVR-300W/IVR-300FP

- Dual-WAN failover and dual-WAN load balancing
- SSL VPN and robust hybrid VPN (IPSec/SSL/L2TP over IPSec)
- Stateful Packet Inspection (SPI) firewall and content filtering
- Blocking DoS/DDOS attack, port range forwarding,
- PLANET DDNS, IPv6, SNMP, Wireless AP management
- Compliant with IEEE 802.11a/b/g/n/ax wireless technology
- IP30 metal case, DIN-rail and wall-mount designs
- -40 to 75oC operating temperature
- 9~54V DC, redundant power with reverse polarity protection function
- PLANET Universal Network Management System



## IVR-100

- Dual-WAN failover and load balancing
- Static Packet Inspection (SPI) firewall and blocks DoS/DDoS attack
- Full security with cybersecurity, VLAN, NAT, DMZ, static/dynamic routing, and IP/MAC/port filtering
- Multiple VPN with IPSEC, OpenVPN, PPTP, L2TP, GRE and VPN failover
- IPv6, PLANET UNI-NMS, easy DDNS
- -40 to 75 degrees C operating temperature and fanless design



## VR-300FW-NR

- Global 5G NR(NSA/SA)/4G LTE network with dual SIM design for cellular network redundancy
- Concurrent dual-band connectivity in 2.4GHz (600Mbps) and 5GHz (1200Mbps)
- One 1000BASE-X SFP slot for WAN interface
- Copper/fiber Dual-WAN failover and Dual-WAN load balancing
- SSL VPN and robust hybrid VPN (IPSec/PPTP/L2TP over IPSec)
- Stateful Packet Inspection (SPI) firewall and content filtering
- High Availability, AP Controller, Captive Portal and RADIUS
- PLANET Universal Network Management System and CloudViewer app supported



## VR-300F/ VR-300FP

- One 1000BASE-X SFP slot for WAN interface
- Copper/fiber Dual-WAN failover and Dual-WAN load balancing
- SSL VPN and robust hybrid VPN (IPSec/PPTP/L2TP over IPSec)
- Stateful Packet Inspection (SPI) firewall and content filtering
- High Availability, AP Controller, Captive Portal and RADIUS
- PLANET Universal Network Management System and CloudViewer app supported



# Industrial 5G NR/4G LTE Security Gateways

## ICG-2515-NR/ICG-2515F-NR

- Global 5G NR(NSA/SA)/4G LTE network with dual SIM design for cellular network redundancy
- 4 10/100/1000T LAN ports and 1 10/100/1000T WAN port
- 2 DI, 2 DO and 1 RS485 port for Modbus applications
- SSL VPN and robust hybrid VPN (IPSec/PPTP/L2TP over IPSec)
- Full security with VLAN, NAT, DMZ, routing, firewall and IP/MAC/port filtering
- PLANET NMS controller system and CloudViewer app supported
- DC 9 to 54V redundant power
- -40 to 75 degrees C operating temperature
- IP30 metal case with DIN-rail or wall-mount design
- 1 1000 BASE-X SFP WAN/LAN port for long distance extension (ICG-2515F-NR)

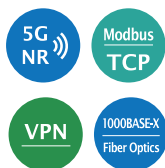

## ICG-2515W-NR/ICG-2515FW-NR

- Global 5G NR(NSA/SA)/4G LTE network with dual SIM design for cellular network redundancy
- Concurrent dual-band connectivity in 2.4GHz (600Mbps) and 5GHz (1200Mbps)
- 4 10/100/1000T LAN ports and 1 10/100/1000T WAN port
- 2 DI, 2 DO and 1 RS485 port for Modbus applications
- SSL VPN and robust hybrid VPN (IPSec/PPTP/L2TP over IPSec)
- Full security with VLAN, NAT, DMZ, routing, firewall and IP/MAC/port filtering
- PLANET NMS controller system and CloudViewer app supported
- DC 9 to 54V redundant power
- -40 to 75 degrees C operating temperature
- 1 1000 BASE-X SFP WAN/LAN port for long distance extension (ICG-2515FW-NR)



## ICG-2210W-NR

- 5G NR (NSA/SA)/4G LTE network with dual SIM design for cellular network redundancy
- 2 Micro SIM slots for cellular network connection
- 1 10/100/1000BASE-T LAN port and 1 10/100/1000BASE-T WAN/LAN ports
- Supports 802.11b/a/g/n/ac for connectivity on mobile clients
- SSL VPN and robust hybrid VPN (IPSec/PPTP/L2TP over IPSec)
- 1 RS485 2-pin and 1 RS232 3-pin interface
- A compact, DIN-rail-mountable IP30 metal case.
- DC 9 to 36 V power input
- -40 to 75 degrees C operating temperature



## FWA-2100-NR

- 5G NR (NSA/SA)/4G LTE network with dual SIM design for cellular network redundancy
- 2 Nano SIM slots for cellular network connection
- 1 10/100/1000BASE-T LAN port
- SSL VPN and robust hybrid VPN (IPSec/PPTP/L2TP over IPSec)
- Blocks DoS/DDOS attack, port range forwarding
- High Availability, AP Controller, Captive Portal and RADIUS
- DC 12V or 802.3at PoE+ input
- IP68 rating
- -20 to 60 degrees C operating temperature
- PLANET NMS controller system and CloudViewerPro app supported



## ICG-2510WG-LTE

- 5-port Gigabit Ethernet, built-in redundant VRRP protocol
- 2 DI/DO and 1 serial port (RS232 or RS485) for Modbus applications
- Dual module SIMs for network load balancing and redundancy
- WiFi compliance IEEE 802.11b/g/n/ac dual-band for mobile client connectivity
- GPS antenna allows to detect the location via sat nav system
- Multiple VPN with IPSEC, OpenVPN, PPTP, L2TP, GRE and VPN failover
- Full security with VLAN, NAT, DMZ, static routing, firewall and IP/MAC/port filtering
- Supports CMS for remote management
- -35 to 70 degrees C operating temperature and fanless design

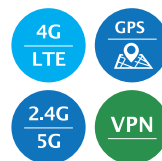

# Industrial Flat-type Routers

PLANET WGR-500-4P is an industrial router with 802.3at PoE+ capability, designed for Internet of Things (IoT) networks. It comes with an intuitive touch panel on its front panel that facilitates the Ethernet PoE PD management that greatly promotes management efficiency in Industrial networks, such as factory, transportation, government buildings, and other public areas. It also features the following special management and operation functions.

## WGR-500-4P

- 4-port 10/100/1000BASE-T with 802.3at PoE+
- 802.1Q VLAN and IGMP proxy
- PoE schedule, scheduled power recycling, PD alive check
- AP auto-discovery
- Central provisioning and cluster management
- Easy deployment with map positioning
- Online firmware detection and batch upgrade
- Real-time AP status monitoring
- Rogue AP detection
- User authentication and MAC ACL
- Customized captive portal
- Profile creation and maintenance



# All-in-One IP KVM Switch Solution for Enterprises

## Remotely Access Your Servers from Anywhere



- Quick View Setting and controls up to 8/16 PCs
- Cascaded to control up to 256 PCs (max.)
- Remote IP KVM bandwidth control
- DES, AES and 3DES data encryption

### 8/16-Port Combo/IP KVM Switch



### 17" 8/16-Port Combo/ IP VGA LCD KVM Switch



\* Windows, iMac, Power Mac, Linux and Sun systems are supported.

# IP KVM

PLANET enterprise IP KVM Switches feature the patented design of the availability of USB and PS/2 interface connection, user-friendly OSD utility and daisy-chain function. In the present computer applications, a mouse has become an indispensable device. The IP KVM fully supports various models of PS/2 mice manufactured by Logitech, Microsoft and IBM as well as compatible PS/2 mice of other brands. The IP KVM supports the PS/2 keyboard port of code set 1/2/3 and further allows you to use the IP KVM for all kinds of servers, computers or their combination.

## IKVM-210-08/IKVM-210-16

- Remote computer control via TCP/IP protocol
- Supports PS/2 and USB compatible mouse/trackball
- Standalone machine controls up to 8/16 computers
- Cascade up to 2 levels, control up to 64/256 computers
- Supports monitor resolution of up to 2048 x 1536
- Computer selection via Port Select Button, Hotkey and On Screen Display (OSD)



## IKVM-210-8M/IKVM-210-16M

- Remote computer control via TCP/IP protocol
- 19-inch 1U rack mountable
- Supports PS/2 and USB compatible mouse/trackball
- Cascade up to 2 levels, control up to 64/256 computers
- Supports high resolution up to 1280 x 1024
- Computer selection via Port Select Button, Hotkey and On Screen Display (OSD)



## KVM-210-8M/KVM-210-16M

- 19-inch 1U rack mountable
- Supports PS/2 and USB compatible mouse/trackball
- Cascade up to 2 levels, control up to 64/256 computers
- Supports high resolution up to 1280 x 1024 (FHD by project optional)
- Computer selection via Port Select Button, Hotkey and On Screen Display (OSD)
- Multiplatform support: Windows 2000/2003/XP/Vista/7/10,11 Linux, Mac, and Sun



## KVM-210-08/KVM-210-16

- Supports PS/2 and USB compatible mouse/trackball
- Standalone machine controls up to 8/16 computers
- Cascade up to 2 levels, control up to 64/256 computers
- Supports monitor resolution of up to 2048 x 1536
- Computer selection via Port Select Button, Hotkey and On Screen Display (OSD)
- QVS (Quick View Setting): Quickly select your computer by naming its model or serial number



# IP Power Managers

With PLANET IP power management device, users can control and monitor a server room locally or remotely through the Internet. When the ESB is attached, the IPM can check the environmental condition as well; meanwhile, users can monitor the status of special environment for security and safety issue. PLANET IPM series not only monitors and manages the power consumption, but also is an ideal application for your computer power management.

## IPM-8221

- 1U rack-mount size design and 8 power outlets that support real-time current image monitoring
- LCD panel displays current, max. alarm, voltage and network information
- Each PDU can supply a maximum load of 3840W with 255 PDUs cascaded
- Enhanced with an environmental sensor to provide a temperature alert via email
- Circuit breaker protection and power usage statistics function
- Power on sequence and the delay time for each socket



## IPM-08220

- 0U rack-mount size design and 8 power outlets that support real-time current image monitoring
- LCD panel displays current, max. alarm, voltage and network information
- Up to 255 PDUs can be cascaded
- Versatile sensors supported through environmental sensor inputs
- Circuit breaker protection and power usage statistics function
- Power on sequence and the delay time for each socket



## IPM-16230

- 0U rack-mount size design and 16 power outlets that support real-time current image monitoring
- LCD panel displays current, max. alarm, voltage and network information
- Up to 255 PDUs can be cascaded
- Versatile sensors supported through environmental sensor inputs
- Circuit breaker protection and power usage statistics function
- Power on sequence and the delay time for each socket

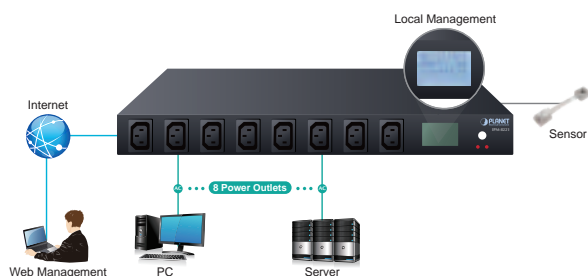

Intelligent Power Management

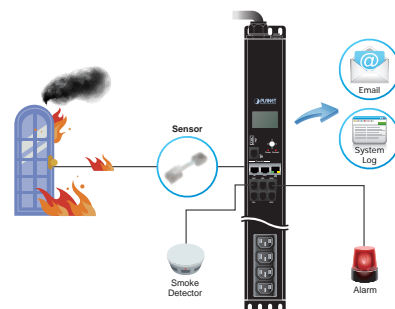

Environmental Sensor Box (ESB)

# HDMI/Video Wall over IP Transmitters/Receivers

## IHD-410PT/IHD-410PR

- Support 1080p or Ultra 4K (3840 x 2160) HDMI resolution with H.264
- IEEE 802.3af Standard PoE Interface
- HDCP-compliant and Blu-ray ready
- Support IR extension and Automatic EDID
- Support USB for KVM PC control
- Assign video sources to any monitors of the video wall
- 1-to-1,1-to-many and multi-casting broadcasting architectures

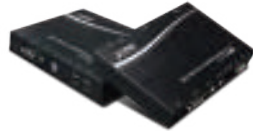

## IHD-210PT/IHD-210PR

- Compatible with H.264 and 1080p HDTV resolution
- IEEE 802.3af Standard PoE Interface
- HDCP-compliant and Blu-ray ready
- High Compression Streaming for saving Bandwidth
- Support IR extension and Automatic EDID
- 1-to-1,1-to-many and multi-casting broadcasting architectures



## IHD-420PT/IHD-420PR

- Supports 1080p or 4K (3840 x 2160) HDMI resolution with refreshing 60 frames per second
- Supports IR extension for controlling video source
- Supports RS232 bi-directional remote extension
- Assigns video sources to any monitor of the video wall system
- The selectable 64-channel DIP switch is easily applied for multi-casting group matching
- IEEE 802.3af/at PoE+ function supported; no additional power supply needed



## Video Wall

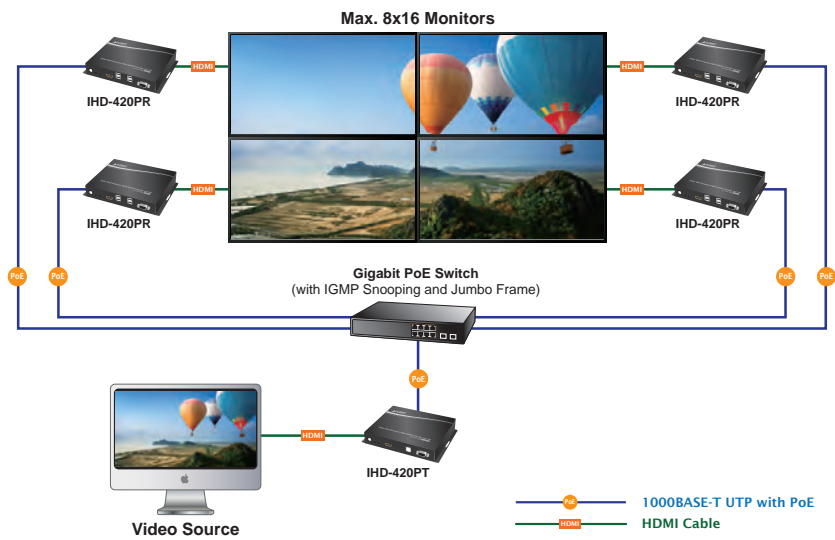

# Ethernet Adapters

Model	ENW-9701	ENW-9801	ENW-9803	ENW-9720P	ENW-9740P
Product Image					
Attached Interface	PCI Express 2.0	PCI Express 2.0	PCI Express 2.0	x4 PCI Express v2.0	x4 PCI Express v2.1
Network Interface	1000BASE-X	10G BASE-SR/LR	10G BASE-T, 100/1000/2500/5000/10G Mbps	Dual Port 10/100/1000 Mbps	Quad Port 10/100/1000 Mbps
Media Interface	SFP	1 x SFP+	RJ45	RJ45	RJ45
BootROM Socket	-	-	-	-	-
Wake on LAN	-	-	-	-	-
OS Support	Windows 10	•	•	•	•
	Windows 7	•	-	•	•
	Windows XP	•	•	•	•
	Windows 2008	•	•	•	•
	Vista	•	•	•	•
	Linux	•	•	•	•



## Digital Media Center/IP Set-Top Box/Multimedia

PLANET Digital Media Center Solutions allow users to watch digital music videos, movies and photos on any TV at home without running wires. With elegant and easy-to-navigate menu screens, you can view family slideshows or browse your music collection by listening to entire playlists, or choosing from a vast selection of Internet TV/radio stations all over the world.

- Surfing Internet on TV easily
- Full HD (1080p) & HDMI
- Listen to digital music on your stereo system
- View digital photo, slideshow, and video on TV
- UPnP AV and DLNA compliant for maximum compatibility
- Quick access to your media contents via the remote controlled TV interface
- Stream media contents from a PC or digital device to your entertainment center

### DMA-200

- Instant access video, music, and photo on USB devices via a built-in USB 2.0 connector
- Internet radio (Live 365, vTuner, etc.)
- Favorite Web TV/photo/radio station gallery
- BitTorrent downloading



### ITB-3001

- Built-in VLC station for IPTV demo
- Built-in Flickr for photo sharing
- Broadcast TV & Time-Shift TV
- Multicast IPTV & Video-on-Demand (VoD)
- Electronic program guide and digital rights management (Available on demand with Telco head-end system)



### DTR-100D

- Compliant with DVB-T standard
- Real-time digital video recording (MPEG-2 compression)
- HDTV quality/Snapshot in JPEG format
- Schedule recording/time-shifting
- EPG (Where available)/Teletext (Where available)
- Multi-channel preview/channel auto scan/portable receiver/subtitle
- Compliant with USB specification Rev 2.0
- Multiple languages



## Powerline Ethernet Bridges

PLANET provides several types of powerline products to meet various demands on Internet access sharing at home. Users may connect an IP STB to the Powerline Adapter, or connect a PC to the Powerline Adapter in the house freely. With PLANET powerline products applied, no messy network cables and additional switches are required at home and users can entirely enjoy home broadband network from now on.

- HomePlug AV compliant
- IEEE 802.3, IEEE 802.3u, IEEE 1901 and HomePlug AV
- 128-bit AES link encryption for security and reliability
- IGMP snooping for multicast to multiple uni-cast mapping
- Quality of Service (QoS) feature
- Green technology applied
- Up to 16 Power lines
- Easy-to-use utility

### PL-104U

- Fully complies with HomePlug Powerline Alliance Specification 1.0
- Data rate of up to 14Mbps within wiring of 60 meters over existing electrical wiring
- Easy to read LED indicators



# Cloud Home Automation

Enjoy a Smart, Safe and User-friendly Lifestyle



PLANET Home Automation system keeps you safe, manages energy consumption, and provides entertainment. The system utilizes a power line and one single network to combine various household facility applications, including camera monitoring, access control, intercom, security, scene control, and value-added services to bring a comfortable, convenient, and happy new life to you.

## HAC-1000

Z-Wave Home Automation Control Gateway

- Powerful home control and Z-Wave Plus™ certified
- 24-hour emergency monitoring
- Energy and cost saving by pre-defined scene modes
- Ensures entry doors are closed and locked remotely
- App and control pad alerts for any situation
- Z-Wave Frequency: America: 908.42MHz, Europe: 868.42MHz
- Hands-free control with Amazon Alexa



WORKS WITH  
**amazon alexa**



## VTS-700WP

7-inch SIP Indoor Touch Screen PoE Video Intercom with Built-in Wi-Fi

- Stylish 7-inch 1024 x 600 resolution IP Intercom touch screen display
- Powered by PoE or external source
- 8-zone alarm interface available for security control
- Short Circuit Output x 1/Short Circuit Input x 1/RS-485 x1
- Built-in Wi-Fi 2.4G/5G
- Standard SIP protocol compatible with modern IP Intercom systems
- Integrates control gateway and door phone with one control pad
- Real-time image (1080P) monitoring of home and community public cameras



## WGR-500-4P

Industrial Wall-mount Gigabit Router

- 4-port 10/100/1000-T LAN and 1-port 10/100/1000-T WAN
- 802.1Q VLAN and IGMP proxy
- PoE schedule, scheduled power recycling, PD alive check
- IPv6 support for IoT Networking
- Secure firewall protection
- VLAN support for isolated traffic and security
- 4-port 10/100/1000BASE-T with 802.3at PoE+



## ICF-1900

High Definition Touch Color Screen Smart Media Android SIP Conference Phone

- 7-inch color touch screen with Android 9.0 OS
- Plug and Play optional 1080p USB camera with 720P 30fps H.264 video call
- IETE SIP compliant with Transport Layer Security
- Up to 20 SIP lines with 112 one-touch DSS keys
- Dual Gigabit and IEEE 802.3af/at PoE compliant
- Built-in Bluetooth 4.2 and 2.4G/5G Wi-Fi
- Wideband G.722 HD and Opus audio codec with handset and hands-free function



## ICF-2000

7" Smart Media Android SIP Conference Phone with Full HD Camera and Touch Screen

- 7-inch color touch screen with Android 9.0 OS
- 5MP camera with 1080p@30fps H.264 video call
- IETE SIP compliant with Transport Layer Security
- Up to 20 SIP lines with 112 one-touch DSS keys
- Dual Gigabit and IEEE 802.3at PoE compliant
- Built-in 2.4G/5GHz Dual-Band Wi-Fi
- Wideband G.722 HD and Opus audio codec with handset and hands-free function



# SIP Door Phones

PLANET SIP Door Phone series is the ideal solution for communication in general-purpose outdoor and indoor environments. Its sleek and fast-to-install features are combined with advanced technology. It provides visitor communication monitoring and access control. One glance at the display panel will let you know who is standing outside your door. You start a dialogue or open the door lock. In addition, with PLANET IP PBX or Z-Wave Plus Gateway, you can obtain a comprehensive system for door communication or easy integration into an existing home automation system.

- IETE SIP (RFC 3261), STUN (RFC 3489)
- Power over Ethernet IEEE 802.3af/at
- ONVIF compliant for interoperability
- Auto provisioning, TR069, VPN, VLAN, QoS
- Advanced security protection with SRTP/TLS/HTTPS
- Interoperable with all major IP PBX platforms
- AEC, AJB, BNE, CNG, NR, PLC, VAD
- Audio codecs: G.711 A-law,  $\mu$ -law, G.722 (wideband), G.723, G.726 and G.729AB

## HDP-1261PT

1080p SIP Vandalproof Door Phone with RFID and PoE

- With high protection level of IP66 and IK07, wide temperature range from -40 to 70 degrees C
- Support to open the door with RFID/IC cards, NFC, indoor switch, remote DTMF, Timed open door
- Built in 2M pixels wide-angle camera: 120°(H), 60°(V) with infrared night-vision feature
- Compatible with SIP and ONVIF protocols
- Built-in maximum 128GB capacity TF card slot for image storage
- HD voice speech quality with built-in 2.5W speaker and Acoustic Echo Canceller

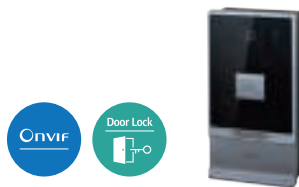

## HDP-5260PT

720p SIP Multi-unit Apartment Vandalproof Door Phone with RFID and PoE

- 720p HD camera with 3 IR LEDs
- Wideband G.722 HD audio
- Anti-vandal solution
- IP65 and IK10 for rigorous environment
- -40 to 70 degrees C operating temperature
- Unlock the door with an RFID, remote DTMF or local password



# Z-Wave Plus Sensors

## HZS-100

Z-Wave Wall-mount Motion Sensor

- 120-degree motion detection
- Tamperproof protection and report
- Low-power consumption
- Battery capacity detection
- Powerful home control and Z-Wave Plus™ certified
- Z-Wave Frequency: America: 908.42MHz, Europe: 868.42MHz



## HZS-200

Z-Wave Ceiling-mount Smoke Detector

- Photoelectric sensor is particularly effective in detecting smoldering fires
- Built-in 85dB sounder and flashing red LED indicate presence of smoke
- Tamperproof protection and report
- Low-power consumption
- Powerful home control and Z-Wave Plus™ certified
- Z-Wave Frequency: America: 908.42MHz, Europe: 868.42MHz



## HZS-300

Z-Wave 4-in-1 Multi Sensor

- Door/Window contact, humidity, temperature and light sensor
- Door and window protection against unauthorized entry
- Tamperproof protection and report
- Low-power consumption and battery capacity detection
- Powerful home control and Z-Wave Plus™ certified
- Z-Wave Frequency: America: 908.42MHz, Europe: 868.42MHz



## HZS-530 Series

Z-Wave Smart Energy Meter

- Energy and cost saving by setting up an automatic power on and off schedule
- Repeater to enhance the Z-Wave wireless communication range
- Voltage, current, wattage and total kWh report
- Overload protection
- Powerful home control and Z-Wave Plus™ certified
- Z-Wave Frequency: America: 908.42MHz, Europe: 868.42MHz





# PLANET Mobile-friendly Feature-rich Online Resources



## PLANET Global Website

PLANET global website that features an innovative and rich product knowledge database with more user-friendly interfaces. Here you can find:

- Product introduction, download resources, and related products
- VR Exhibition
- Latest corporate and products news
- PLANET eTV Channel for various videos
- Product solutions and applications
- Download center -- FAQs, support resources
- Product selectors and product tools



Mobile-friendly & Responsive Website Design

In Partner Area, we provide registered partners with up-to-date information and useful marketing tools that help you sell PLANET products and solutions for expanding your revenue opportunities:

- Support and Downloads include photos, EC declaration, emulators, sales guides, datasheets, drivers, etc.
- Marketing Tools cover a wide variety of product catalogues and corporate brand tools.
- Case studies on successful reference sites are shared among our worldwide partners.



### PLANET Facebook Fan Page

<http://www.facebook.com/PLANETTechnology>

PLANET Facebook Fan Page is delivered to facilitate better exchange of information and interaction with our global customers. On our page, you can:

- Hear the latest news on PLANET
- Get the updated PLANET product information
- Share your experience with PLANET



### PLANET YouTube Channel

<http://www.youtube.com/user/PLANETTechnology>

Aiming to provide user-friendly and feature-rich multimedia contents, PLANET provides a wide variety of the following videos on YouTube Channel:

- Corporate Introduction
- Product Solutions
- Product Demo
- Webinars
- IP Surveillance Live Clips
- Exhibition Highlights



### PLANET LinkedIn Company Page

<https://tw.linkedin.com/company/planet-technology-hq>

Connect with us on LinkedIn. Here you'll find various useful information for you and your company.

- New technology sharing
- Latest product launches
- Solution video announcements
- News and events releases



### Easy & Free PLANET DDNS Service

<http://www.planetddns.com/>

PLANET DDNS website provides a variety of products, such as PLANET IP Cameras, Router, and NAS, to support FREE Dynamic IP domain name service. Once the users register a simple and easy-to-remember domain name for your product in PLANET DDNS website, you can access and manage your devices anytime, anywhere.

# 2024 COMPUTEX Best Choice Award

## Category Award & Sustainable Tech Special Award



Best Choice Award



Sustainable Tech Special Award



### Worldwide Recognitions





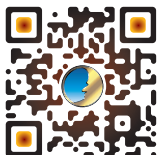

**PLANET Technology Corporation**

11F., No. 96, Minguan Rd., Xindian Dist., New Taipei City 231, Taiwan (R.O.C)  
TEL: 886-2-2219-9518 FAX: 886-2-2219-9528 E-mail: [sales@planet.com.tw](mailto:sales@planet.com.tw)

PLANET reserves the right to change specification without notice. All brand names and trademarks are property of their respective owners.  
© PLANET Technology Corporation C-0125-EP